

DR 400

5520/100

5520/200

User Manual



Contents

Legal Notice.....	7
Introduction to this Manual.....	7
Scope of this Manual.....	8
About the safety notices in this document.....	9
Disclaimer.....	10
Introduction to DR 400.....	10
Intended Use.....	11
Intended User.....	12
Configuration.....	13
Applied Parts.....	14
Options and Accessories.....	15
Operation Controls.....	16
Radiographic table.....	17
Radiographic wall stand.....	18
Control Panel of the X-Ray Tube Stand.....	19
Tube head display.....	20
MUSICA Acquisition Workstation (NX).....	21
Software Console.....	22
DR Detector Switch.....	23
X-ray generator mini console.....	24
Manual collimator.....	26
Automatic collimator.....	27
Portable DR detector.....	28
Emergency stop button.....	29
Emergency shutdown power switch.....	30
Installation.....	31
HF-emission and immunity.....	32
Radiation protection.....	32
Radiation Protection.....	33
Monitoring of Personnel.....	34
Protected area and significant zones of occupancy.....	35
Labels.....	41
Warning labels on the radiographic table.....	43
Warning labels on the radiographic wall stand.....	44
Type label.....	45
DR Detector identification label.....	46
Additional Labeling of the radiographic table.....	47
Additional Labeling of the radiographic wall stand.....	49
Labeling of the bucky.....	50
Labeling of the Automatic Exposure Control (AEC).....	51
Labeling of the DR Generator Sync Box.....	52
Labeling of the X-ray generator mini console.....	53
Cleaning and Disinfecting.....	54
Cleaning.....	55
Disinfecting.....	56

Disinfecting safety directions.....	57
Approved disinfectants.....	58
Maintenance.....	59
Maintenance of the radiographic table, radiographic wall stand and X-Ray Tube Stand.....	59
Safety Directions.....	61
General Safety Directions.....	62
Safety Directions for the X-Ray System.....	63
Safety Directions for the radiographic table.....	64
Basic Workflow.....	64
Starting the System.....	65
Automated workflow for warming-up of X-ray tube.....	65
Performing an exposure using the DR Detector.....	67
Step 1: retrieve the patient info.....	68
Step 2: select the exposure.....	69
Step 3: prepare the exposure.....	70
Step 4: check the exposure settings.....	71
Step 5: execute the exposure.....	72
Step 6: perform a quality control.....	72
Performing an exposure using a CR cassette.....	73
Step 1: retrieve the patient info.....	74
Step 2: select the exposure.....	75
Step 3: prepare the exposure.....	76
Step 4: check the exposure settings.....	76
Step 5: execute the exposure.....	77
Step 6: repeat steps 2 to 5 for the next subexposures.....	77
Step 7: digitize the image.....	77
Step 8: perform a quality control.....	77
X-Ray System Positioning.....	78
Radiographic table exposures.....	79
Oblique Exposures.....	80
Lateral Exposures.....	81
Radiographic wall stand exposures.....	82
Stopping the System.....	83
Guidelines for pediatric applications.....	84
Guidelines for Pediatric Applications.....	84
Software Console and Tube Head Display.....	85
Cleaning the tube head display.....	86
Planned exposures.....	87
X-ray image preview screen.....	88
Main screen of the Tube head display.....	89
Position parameters.....	90
X-ray tube stand tracks table height.....	91
X-ray tube stand tracks wall stand height.....	92
Collimator Parameters.....	93
X-ray modality status frame.....	94
Ready for exposure status.....	95
Modality Position.....	96
DR Detector Switch.....	97
Filter Status.....	98

Anti-scatter grid status.....	99
Radiation status.....	100
Unknown status.....	101
Generator screen.....	102
One point, two point and three point working modes.....	103
Radiographic Parameters.....	104
Focal Spot Indicator.....	105
Automatic Exposure Control (AEC).....	106
X-ray tube load.....	109
DAP Value.....	110
Heat Units.....	111
X-ray modality screen.....	112
System messages screen.....	113
Radiographic Table and X-Ray Tube Stand.....	114
Positioning the X-Ray Tube Stand.....	117
Stop positions.....	119
Collision indicator.....	120
Positioning the radiographic table.....	121
Positioning the floating tabletop.....	122
Adjusting height.....	123
Positioning the Bucky.....	124
Radiographic Table Accessories.....	125
Mounting the patient hand grips.....	126
Mounting the tabletop hand grips.....	127
Collision protection.....	128
Mattress.....	129
Lateral cassette holder.....	130
Compression belt.....	131
Manual Collimator.....	132
Dose Area Product Meter (DAP).....	132
Automatic Collimator.....	134
Semi-automatic collimation mode.....	135
Manual collimation mode.....	136
Dose Area Product Meter (DAP).....	137
Effect of SID on patient dose.....	138
Radiographic wall stand.....	138
Positioning the Radiographic Wall Stand.....	140
Radiographic Wall Stand Accessories.....	142
Patient hand grips.....	143
Mounting the lateral arm rest.....	144
Spacer.....	145
Wall stand fixation kit.....	146
Bucky.....	146
Bucky configuration.....	148
Rotating the bucky.....	149
Loading of the bucky in the Radiographic Table.....	150
Loading of the bucky in the Radiographic Wall Stand.....	151
Unloading of the bucky in the Radiographic Table.....	152
Unloading of the bucky in the Radiographic Wall Stand.....	153
Automatic Cassette Size Sensing.....	154

Centering and collimating.....	155
Bucky types.....	157
Cassette and detector formats.....	159
Standard cassette formats.....	160
DR Detector formats and orientation.....	161
Orientation of DR 10s in the bucky.....	162
Orientation of DR 14s in the bucky.....	164
Orientation of DX-D 10C, DX-D 10G in the bucky.....	166
Using DX-D 45C, DX-D 45G, XD 10, XD*10 only outside the bucky.....	168
Anti-scatter grids.....	169
Anti-scatter grids.....	170
Anti-scatter grid focal distance color indication.....	171
Anti-scatter grid detection.....	171
Storage box for DR detector and anti-scatter grids.....	172
Automatic Exposure Control (AEC).....	173
X-Ray Generator Mini Console.....	173
Starting and stopping the generator.....	174
X-ray tube start-up modes.....	175
X-ray generator messages and warning signals (Spellman).....	176
Exposure parameters.....	177
Radiographic Parameter Limits.....	179
Exposure termination.....	180
Problem solving.....	180
Restoring connection between generator and NX after generator failure.....	181
Automatic collimation always too wide or too narrow.....	182
Empty Bucky Failure, Double Exposure Failure.....	183
NX does not connect to the generator due to ID tablet.....	184
No table movement.....	185
DR Detector is Exceeding the Maximum Working Temperature.....	186
DR detector must be recalibrated.....	187
System does not start completely if collimator is in manual mode.....	188
Tube head display shows screen to check network connection.....	189
Radiographic Parameter Limits.....	190
Product Information.....	190
Compatibility.....	191
Connectivity.....	192
Compliance.....	193
General.....	194
Safety.....	194
Electromagnetic Compatibility.....	195
X-Ray Safety.....	195
X-Ray Accuracy.....	195
Environmental Compliance.....	195
Biocompatibility.....	195
Usability.....	195
Equipment Classification.....	196
Patient data security.....	197
Requirements on the operating environment.....	198
Security settings.....	199
Product Complaints.....	200

Environmental protection.....	201
System Documentation.....	202
Training.....	203
Technical Data.....	204
DR 400 Technical Data.....	205
Generator Technical Data.....	207
Radiographic Table and X-Ray Tube Stand Technical Data.....	208
Radiographic Wall Stand Technical Data.....	210
X-Ray Tube Technical Data.....	212
Bucky Unit Technical Data.....	213
Automatic Exposure Control (AEC) Technical Data.....	215
Manual Collimator Technical Data.....	216
Automatic collimator technical data.....	217
Dose Area Product Meter (IBA DAP) Technical Data.....	218
Dose Area Product Meter (VacuTec DAP) Technical Data.....	219
Fixed DR Detector.....	220
Portable DR detector technical data.....	225
NX workstation technical data.....	226
DR Generator Sync Box technical data.....	227
Remarks for HF-emission and immunity.....	228
Immunity to RF wireless communication equipment.....	232
Precautions on EMC.....	233
Cables, transducers and accessories.....	234
Maintenance on EMC relevant parts.....	236

Legal Notice

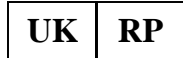

Agfa HealthCare UK Limited, 6-9 The Square, Stockley Park, Uxbridge, Middlesex UB11 1FW, UK

 Agfa NV, Septestraat 27, 2640 Mortsel - Belgium

For more information on Agfa products, please visit medimg.agfa.com.

Agfa and the Agfa rhombus are trademarks of Agfa-Gevaert N.V., Belgium or its affiliates. DR 400 is a trademark of Agfa NV, Belgium or one of its affiliates. All other trademarks are held by their respective owners and are used in an editorial fashion with no intention of infringement.

Agfa NV makes no warranties or representation, expressed or implied, with respect to the accuracy, completeness or usefulness of the information contained in this document and specifically disclaims warranties of suitability for any particular purpose. Products and services may not be available for your local area. Please contact your local sales representative for availability information. Agfa NV diligently strives to provide as accurate information as possible, but shall not be responsible for any typographical error. Agfa NV shall under no circumstances be liable for any damage arising from the use or inability to use any information, apparatus, method or process disclosed in this document. Agfa NV reserves the right to make changes to this document without prior notice. The original version of this document is in English.

Copyright 2023 Agfa NV

All rights reserved.

Published by Agfa NV

2640 Mortsel - Belgium.

No part of this document may be reproduced, copied, adapted or transmitted in any form or by any means without the written permission of Agfa NV

Introduction to this Manual

- [Scope of this Manual](#) on page 8
- [About the safety notices in this document](#) on page 9
- [Disclaimer](#) on page 10

Scope of this Manual

This User Manual describes the features of the DR 400 System, an integrated X-Ray imaging system. It explains how the different components of the DR 400 System work together.

About the safety notices in this document

The following samples show how warnings, cautions, instructions and notes appear in this document. The text explains their intended use.



DANGER: A danger safety notice indicates a hazardous situation of direct, immediate danger for a potential serious injury to a user, service engineer, patient or any other person.



Warning: A warning safety notice indicates a hazardous situation which can lead to a potential serious injury to a user, service engineer, patient or any other person.



Caution: A caution safety notice indicates a hazardous situation which can lead to a potential minor injury to a user, service engineer, patient or any other person.



An instruction is a direction which, if it is not followed, can cause damage to the equipment described in this manual or any other equipment or goods and can cause environmental pollution.



A prohibition is a direction which, if it is not followed, can cause damage to the equipment described in this manual or any other equipment or goods and can cause environmental pollution.



Note Notes provide advice and highlight unusual points. A note is not intended as an instruction.

Disclaimer

Agfa assumes no liability for use of this document if any unauthorized changes to the content or format have been made.

Every care has been taken to ensure the accuracy of the information in this document. However, Agfa assumes no responsibility or liability for errors, inaccuracies or omissions that may appear in this document. To improve reliability, function or design Agfa reserves the right to change the product without further notice. This manual is provided without warranty of any kind, implied or expressed, including, but not limited to, the implied warranties of merchantability and fitness for a particular purpose.



Note In the United States, Federal law restricts this device on order of a physician for prescription use only.

Introduction to DR 400

- [Intended Use](#) on page 11
- [Intended User](#) on page 12
- [Configuration](#) on page 13
- [Options and Accessories](#) on page 15
- [Operation Controls](#) on page 16
- [Installation](#) on page 31
- [Radiation Protection](#) on page 33
- [Labels](#) on page 41
- [Cleaning and Disinfecting](#) on page 54
- [Maintenance](#) on page 59

Intended Use

- The DR 400 system is a General Radiography X-ray imaging system used in hospitals, clinics and medical practices by physicists, radiographers and radiologists to make, process and view static X-ray radiographic images of the skeleton (including skull, spinal column and extremities), chest, abdomen and other body parts on adult or pediatric patients.
- Applications can be performed with the patient in the sitting, standing or lying position.
- This device is not intended for mammography applications.

Intended User

This manual has been written for trained users of Agfa products and trained diagnostic X-Ray clinical personnel who have received proper training.

Users are those persons who actually handle the equipment and those who have authority over the equipment.

Before attempting to work with this equipment, the user must read, understand, note and strictly observe all warnings, cautions and safety markings on the equipment.

Configuration

DR 400 is a configurable DR (Direct Radiography X-ray system) or CR (Computed Radiography) X-ray system.

The complete DR 400 consists of the following components:

- Radiographic table with an integrated Fixed DR Detector or with a bucky. In the bucky a DR Detector or a CR cassette can be inserted.
- Radiographic wall stand with an integrated Fixed DR Detector or with a bucky. In the bucky a DR Detector or a CR cassette can be inserted.
- Bucky with integrated battery charger for DR 14s detectors (optional)
- X-ray tube stand mounted on the radiographic table
- X-ray generator integrated in the radiographic table
- X-ray generator mini console
- X-ray tube with manual or automatic collimator
- NX image processing software on the NX workstation
- DR Generator Sync Box (depending on the configuration)
- Automatic Exposure Control (AEC)
- Dose Area Product Meter (DAP, optional)

DR 400 also has a configuration without radiographic wall stand.

Depending on the configuration the following components are also available:

- Portable DR Detector

DR 400 can be used in combination with:

- DX-G
- DX-M
- CR 30-X (5175/2XX)
- CR 30-Xm
- CR 10-X
- CR 12-X
- CR 15-X

DR 400 has three main configurations:

1. DR configuration with X-ray exposure parameter control on the NX workstation.
2. CR configuration with X-ray exposure parameter control on the NX workstation.
3. Mixed DR and CR configuration with X-ray exposure parameter control on the NX workstation.

X-ray parameters are controlled using the Software Console on the NX workstation.

The Software Console is available on the NX workstation, to synchronize the X-ray exposure parameters between the NX application and the generator.

Other configurable features include:

- Tube head display with controls for X-ray exposure parameters
- Position tracking for keeping constant SID on table and wall stand
- Bucky with automatic cassette size sensing (ACSS) and automatic collimator

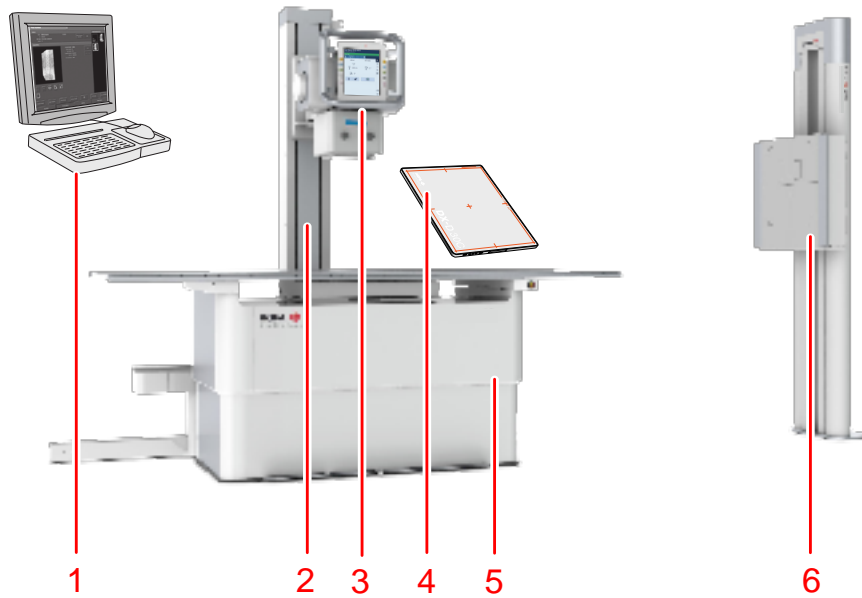

1. NX workstation
2. X-ray tube stand mounted on the radiographic table
3. X-ray tube with collimator and tube head display
4. Portable DR Detector
5. Radiographic table with integrated generator
6. Radiographic wall stand

Figure 1: DR 400 configuration for DR

- [Applied Parts](#) on page 14

Applied Parts

Applied Parts refer to parts of the medical electrical equipment that in normal use necessarily comes into physical contact with the patient for the equipment to perform its function. This system includes the following Applied Parts:

Radiographic table

- Table top of the radiographic table
- Patient hand grips (optional)
- Lateral cassette holder (optional)
- Mattress (optional)
- Compression belt (optional)

Radiographic wall stand

- Front panel of the radiographic wall stand
- Lateral arm rest (optional)
- Patient hand grips (optional)

DR Detector

- DR Detector

Options and Accessories

The system is delivered with a set of labels. When using multiple DR Detectors, on the labels a nickname is written to identify the DR Detector. An identical label is attached to the bucky of the X-ray system to identify the dedicated workspace of each DR Detector.

For information on options and accessories of the DR Detector, refer to the user manual of the DR Detector.

Related information

[Radiographic Table Accessories](#) on page 125

[Radiographic Wall Stand Accessories](#) on page 142

Operation Controls

- [Radiographic table](#) on page 17
- [Radiographic wall stand](#) on page 18
- [Control Panel of the X-Ray Tube Stand](#) on page 19
- [Tube head display](#) on page 20
- [MUSICA Acquisition Workstation \(NX\)](#) on page 21
- [Software Console](#) on page 22
- [DR Detector Switch](#) on page 23
- [X-ray generator mini console](#) on page 24
- [Manual collimator](#) on page 26
- [Automatic collimator](#) on page 27
- [Portable DR detector](#) on page 28
- [Emergency stop button](#) on page 29
- [Emergency shutdown power switch](#) on page 30

Radiographic table

The radiographic table is used for positioning of the patient lying or sitting over the detector or the cassette in the bucky for exposure.

The radiographic table supports the patient and the detector or the cassette for free exposure.



Figure 2: Radiographic table

Related information

[Radiographic Table and X-Ray Tube Stand](#) on page 114

Radiographic wall stand

The radiographic wall stand is used for positioning of patients standing upright or sitting towards the bucky for exposure.



Figure 3: Radiographic wall stand with vertical bucky

Related information

[Radiographic wall stand](#) on page 138

Control Panel of the X-Ray Tube Stand



Figure 4: Control Panel of the X-Ray Tube Stand with tube head display (controls for X-ray tube position and for X-ray exposure parameters)



Figure 5: Control Panel of the X-Ray Tube Stand with X-ray tube angle display

Related information

[Radiographic Table and X-Ray Tube Stand](#) on page 114

Tube head display

The tube head display can be used to control X-ray exposure parameters. It displays the system status.

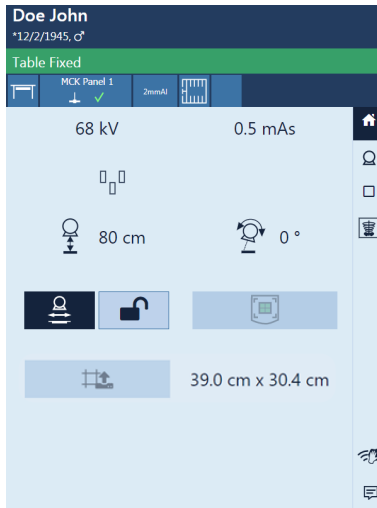

Figure 6: Example of the tube head display

Related information

[Software Console and Tube Head Display](#) on page 85

MUSICA Acquisition Workstation (NX)

The MUSICA Acquisition workstation is used to define patient information, select exposures and process images.

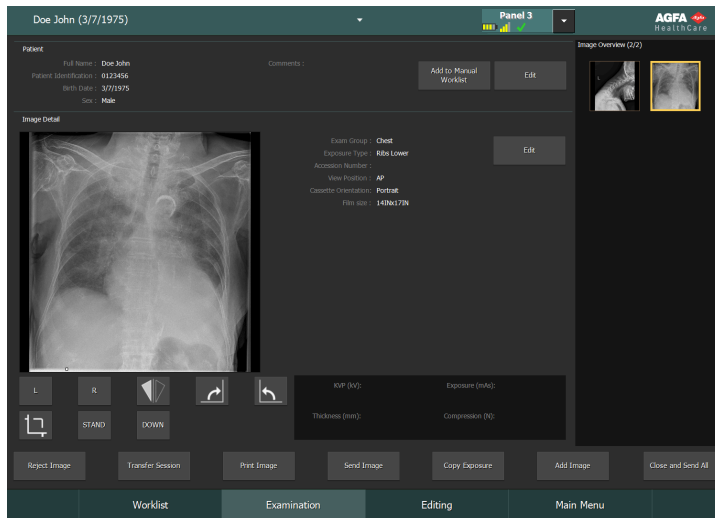

Figure 7: MUSICA Acquisition workstation software

The operation of the workstation application is described in the MUSICA Acquisition Workstation User Manual, document 4420.

The software is further referred to as "NX" and the PC on which it runs the "NX workstation".

Software Console

The Software Console is available to support X-ray exposure and position parameter control on the NX workstation. It is displayed on the NX workstation next to the NX application.

The Software Console is used to control the X-ray exposure settings.

The Software Console contains the DR Detector Switch.

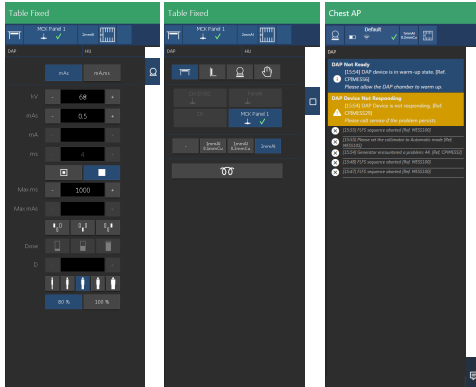

Figure 8: Software console controls for generator, X-ray modality and system messages

Related information

[Software Console and Tube Head Display](#) on page 85

DR Detector Switch

The DR Detector Switch shows which DR Detector is active and shows its status. The DR Detector Switch can be used to activate another DR Detector. The DR Detector Switch can be switched to CR, depending on the configuration.

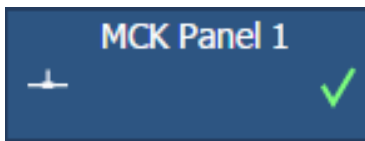
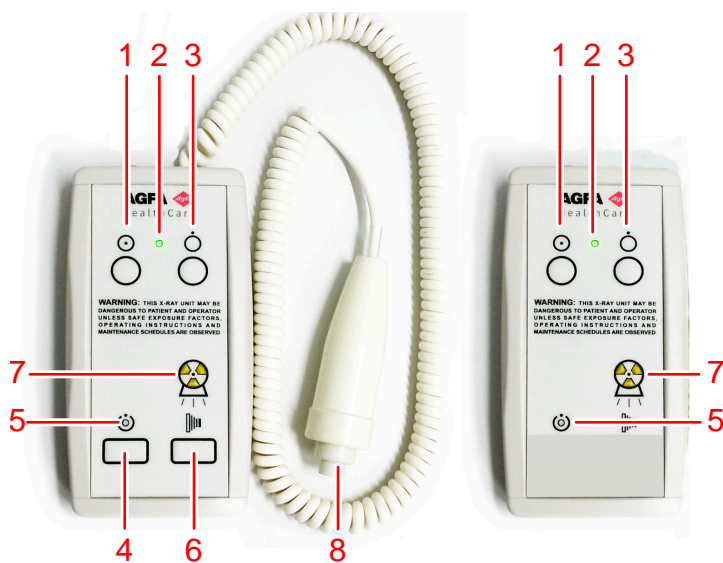

Figure 9: DR Detector Switch

X-ray generator mini console

The X-ray generator mini console is available in the operator room.



1. Power ON button
2. Power ON indicator
3. Power OFF button
4. Press and hold to prepare for exposure
5. Prepare ready indicator
6. Press and hold to start the exposure
7. Radiation indicator
8. Exposure button

Figure 10: X-ray generator mini console

Exposure button

Preparing for exposure

Press the exposure button down to the first pressure point and hold it for approximately 0.5 s to 2 s.



The X-ray tube is prepared for performing an exposure.



Caution: Wear of X-ray tube due to prolonged preparing of the X-ray tube.

Starting the exposure

Before starting the exposure:

1. Check if the exposure settings displayed on the console are suitable for the exposure.
2. Check the Ready for Exposure status.

Press the exposure button down fully and keep it pressed until the exposure has ended.



The radiation indicator on the control console lights up and a signal sounds to indicate the exposure.



Caution: Releasing the exposure button ends the exposure immediately and the image can be underexposed.

Manual collimator

The collimator sets the exposure field and displays it by means of a light field.

The collimator provides X-ray filtering using the integrated filters or by inserting a filter in the rails.

A DAP meter (Dose Area Product Meter) can be mounted on the collimator by inserting it in the rails.



Figure 11: Collimator

Related information

[Manual Collimator Technical Data](#) on page 216

Automatic collimator

The collimator sets the exposure field and displays it by means of a light field.

The collimator provides X-ray filtering using the integrated filters or by inserting a filter in the rails.

An integrated DAP meter (Dose Area Product Meter) in the collimator is available as an option.

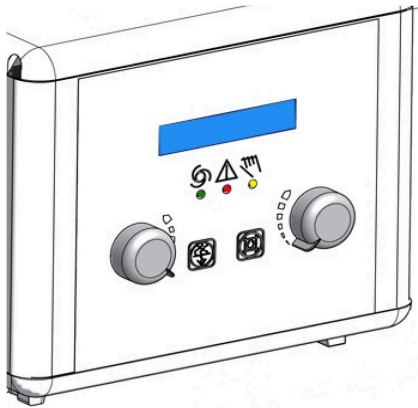

Figure 12: Collimator

Related information

[Automatic Collimator](#) on page 134



[Automatic Cassette Size Sensing](#) on page 154

[Automatic collimator technical data](#) on page 217

Portable DR detector

When performing an exposure, keep in mind the following detector orientation aids:

Table 1: Orientation aids

	Tube side icon, indicating the side that faces the X-ray tube
	Patient orientation marker, filled rectangle printed at the corner of the detector, for consistent orientation relative to the patient

For an overview of the operation controls of the DR detector, refer to the user manual of the DR detector.

The DR detector may come in contact with the patient.



Note DR detectors that operate wireless contain an RF transmitter. For detailed information, refer to the DR detector user manual.

Emergency stop button



Figure 13: Emergency stop button

If a system malfunction causes an emergency situation involving the patient, operating personnel or any system component, activate the emergency stop on the radiographic table. All motor driven movements will be stopped.

Motor driven movements:

- Radiographic table
- Radiographic wall stand
- X-ray tube stand

To allow motorized movements again, turn the cap of the emergency switch in clockwise direction (default position).



Warning: The emergency stop button does not switch off the voltage in the X-ray system.

Emergency shutdown power switch

Use the emergency shutdown power switch, if a dangerous situation cannot be eliminated by pressing the emergency stop button.



Warning: Use the emergency shutdown power switch in case of danger to patients, operators, third parties, or one of the units. The entire system will be shut down and the power supply will be disconnected.

The emergency shutdown power switch for the room is typically located on the wall and easy to access, often close to the power off switch of the X-ray system. It is installed and labeled by customer.



Warning: It must be ensured that the emergency switches are always freely accessible.

Installation

Installation and configuration is performed by an Agfa trained and authorized service engineer. Contact your local support organization for more information.

On a configuration with multiple DR detectors of the same type, it is required to apply labeling to the DR detector containing a unique nickname for each DR detector. The nicknames must be configured on the MUSICA Acquisition Workstation. The **DR Detector Switch** shows which DR detector is active and shows its status, by means of the nickname of the DR detector.

An identical label is attached to the bucky of the X-ray system to identify the dedicated workspace of each DR detector.

- [HF-emission and immunity](#) on page 32
- [Radiation protection](#) on page 32

HF-emission and immunity

The HF-emission and immunity can be influenced by connected data cables depending on length and the manner of installation.

A specific installation environment may require special measures to put the system into operation according to the remarks for HF-emission and immunity.

Related information

[Cables, transducers and accessories](#) on page 234

Radiation protection

The system is intended to be used in X-ray rooms with appropriate shielding.

Radiation Protection

X-ray radiation can cause serious damage to the health, therefore observe great care and ensure that protection against X-ray exposure is always applied.

Some of the effects of X-ray radiation are cumulative and may extend over a period of time. Therefore the X-ray operator should avoid exposure by X-ray radiation at all times.

Objects in the path of the X-ray beam may produce scattered radiation. The intensity depends on the energy and intensity of the X-ray exposure, the material of the object and the distance to the object producing scattered radiation. Protective measures have to be taken to prevent exposure through scattered radiation.

Protective measures include:

- structural configuration of the X-ray room (e.g. lead shielded rooms)
- radiation protection for the operators (e.g. personal radiation dosimeters, lead aprons, radiation protection glasses, mobile lead screens, keep maximum distance from X-ray source and from the object producing scattered radiation, regular training, etc.)
- protection of patients against unnecessary radiation (e.g. limitation of X-ray field by collimation, lead shielding, lead aprons, etc.)
- [Monitoring of Personnel](#) on page 34
- [Protected area and significant zones of occupancy](#) on page 35

Monitoring of Personnel

The monitoring checks the amount of X-ray radiation the personnel has been exposed to. It determines safety of the operators and it helps checking if safety measures of the X-ray environment are adequate. Inadequate or improper protection can lead to serious damage to the health.

To measure radiation, personal radiation dosimeters are typically used. They are worn on the body at all times during working in an environment where X-ray radiation is applied. They provide an indication for the amount of radiation the operator was exposed to.

Protected area and significant zones of occupancy

If the operator or staff does not need to be close to the patient during the exposure, the operator and staff use the protected area to control the following functions:

- selection of mode of operation
- selection of exposure settings (X-ray loading factors)
- actuation of the exposure button
- other necessary controls for the operator during exposure

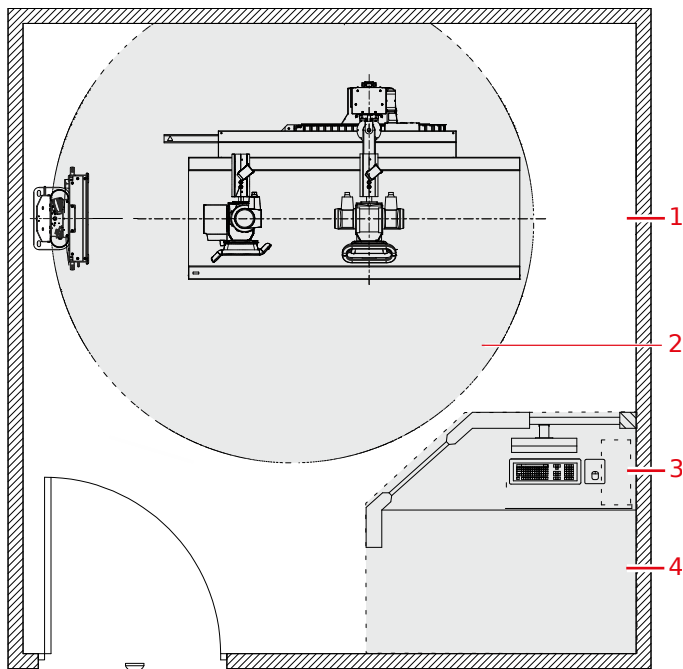

1. X-ray room
2. Patient environment
3. Workstation
4. Operator room: protected area

Figure 14: Protected area and significant zones of occupancy



Warning: The patient must wear appropriate radiation protection garments.

If operator or staff needs to be close to the patient during normal use (e.g. some pediatric examinations or types of examinations for which the patient requires assistance), the significant zone of occupancy applies for operator and staff.

Keep maximum distance from the X-ray source and from the object producing scattered radiation. The intensity of scattered radiation depends on the energy and intensity of the X-ray exposure, the material of the object and the distance to the object.



Warning: The patient and the operator must wear appropriate radiation protection garments.

Related information

[Radiation Protection](#) on page 33

Minimum height above the floor 200 cm.

4. Dose meter
5. DR Detector or cassette
6. S4: Significant zone of occupancy at the left side of the radiographic table
7. S3: Significant zone of occupancy in front of the radiographic table
8. S5: Significant zone of occupancy at the right side of the radiographic table

Figure 15: Significant zones of occupancy at the radiographic table

Related information

[Radiation Protection](#) on page 33

[Scattered radiation \(general radiography\)](#) on page 39

Significant zones of occupancy at the radiographic wall stand

If operator or staff needs to be close to the patient during normal use (e.g. some pediatric examinations or types of examinations for which the patient requires assistance), the significant zone of occupancy applies for operator and staff.

Keep maximum distance from the X-ray source and from the object producing scattered radiation. The intensity of scattered radiation depends on the energy and intensity of the X-ray exposure, the material of the object and the distance to the object.



Warning: The patient and the operator must wear appropriate radiation protection garments.

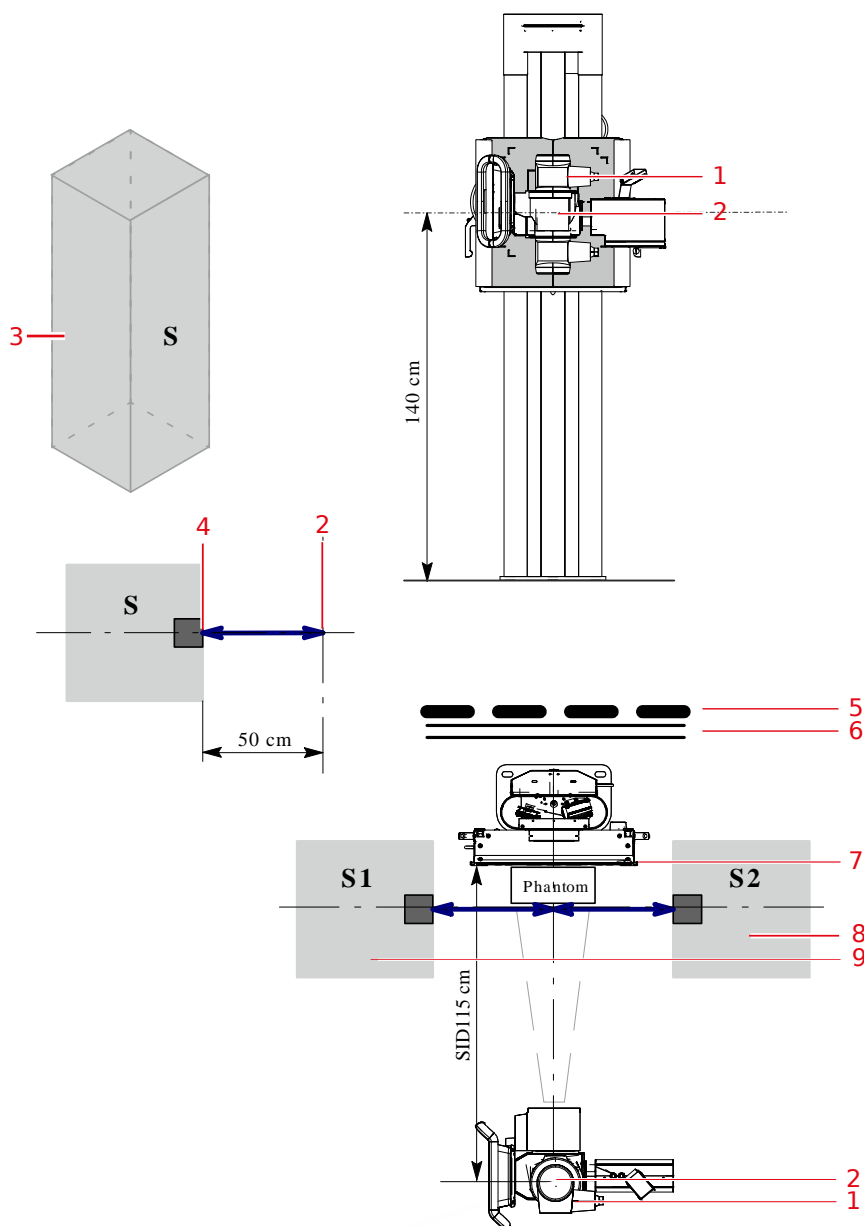

1. X-ray tube
2. Focal spot label [—]
3. Significant zone of occupancy.

Minimum area 60x60 cm.

Minimum height above the floor 200 cm.

4. Dose meter
5. Protective device
6. Wall
7. DR Detector or cassette
8. S2: Significant zone of occupancy at the right side of the radiographic wall stand
9. S1: Significant zone of occupancy at the left side of the radiographic wall stand

Figure 16: Significant zones of occupancy at the radiographic wall stand



Caution: The radiation protection has to be applied for the patient and for the operator.

Related information

[Radiation Protection](#) on page 33

[Scattered radiation \(general radiography\)](#) on page 39

Scattered radiation (general radiography)

The diagram represents the amount of stray radiation that is measured in the significant zone of occupancy.

1. Vertical axis representing the operator positioned in the significant zone of occupation and height range of stray radiation measurement (0 cm - 200 cm)
2. Horizontal axis indicating the stray radiation in mGy measured at a specific height

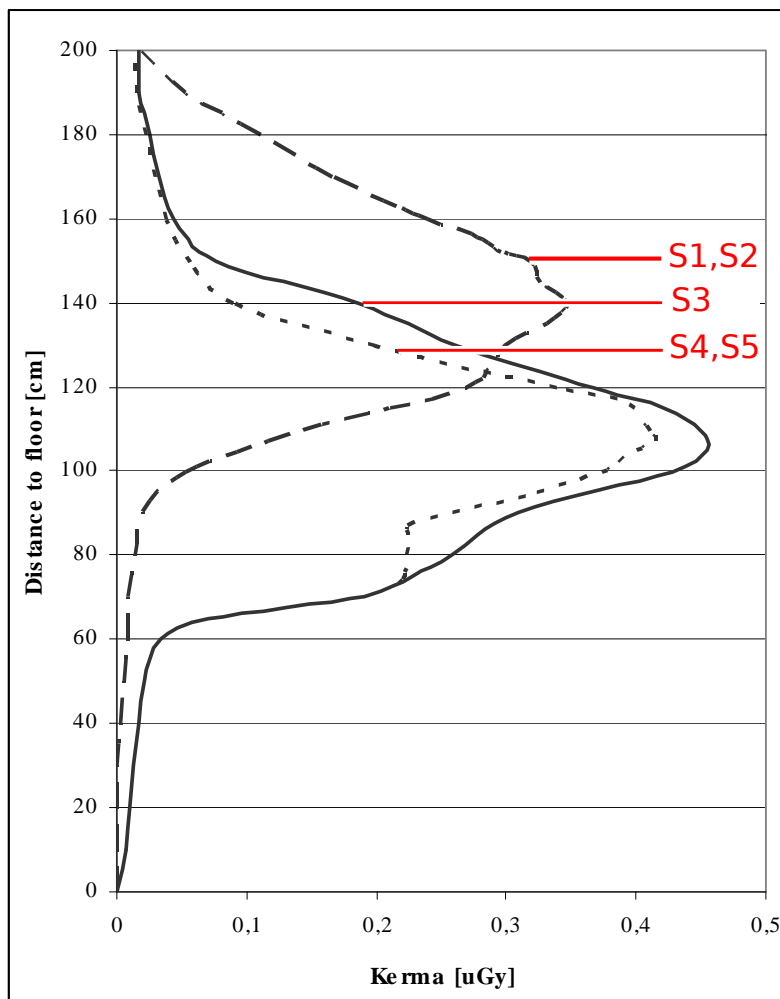

- S1: Significant zone of occupancy at the left side of the radiographic wall stand
- S2: Significant zone of occupancy at the right side of the radiographic wall stand
- S3: Significant zone of occupancy in front of the radiographic table
- S4: Significant zone of occupancy at the left side of the radiographic table
- S5: Significant zone of occupancy at the right side of the radiographic table

Figure 17: Measurement of scattered radiation in zones of occupancy (Sx)

Table 2: Conditions for measuring stray radiation values represented in the illustrations

Workflow	General radiography
----------	---------------------













SID	100 cm (radiographic table) 110cm (radiographic wall stand)
Table height	70 cm
Wall stand position (distance between center of the bucky and the floor)	140 cm
Exposure parameters	100 kV
Total exposure time	For the diagram above a maximum throughput of 30 exposures/hour was used. This complies with a throughput of 15 patients/hour with typically 2 exposures done per patient. The measurement results in the figure above refer to one exposure.



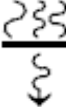

Related information

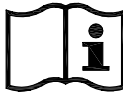
[Significant zones of occupancy at the radiographic table](#) on page 36

[Significant zones of occupancy at the radiographic wall stand](#) on page 37

Labels

Mark	Meaning
	This mark shows compliance of the equipment with Regulation 2017/745 (for European Union).
	Type B applied part
	Date of manufacture
	Country of origin. The two character code on the actual label contains the country code defined in ISO 3166-1.
	Manufacturer
	Medical device
	Serial number
	Unique device identifier, in text format and in machine readable format
	Type and subtype number
	Symbol of filtration.
	Maximum stand-by current
	The most recent version of this document is available on http://www.agfahealthcare.com/global/en/library/index.jsp
	The INMETRO label is positioned close to the type label.

Label	Meaning
	Dangerous voltage
	Ionizing radiation
	Pinch Points.
	Risk of stumbling.

Further labels are listed and explained in the relevant modules of the System Documentation.

- [Warning labels on the radiographic table](#) on page 43
- [Warning labels on the radiographic wall stand](#) on page 44
- [Type label](#) on page 45
- [DR Detector identification label](#) on page 46
- [Additional Labeling of the radiographic table](#) on page 47
- [Additional Labeling of the radiographic wall stand](#) on page 49
- [Labeling of the bucky](#) on page 50
- [Labeling of the Automatic Exposure Control \(AEC\)](#) on page 51
- [Labeling of the DR Generator Sync Box](#) on page 52
- [Labeling of the X-ray generator mini console](#) on page 53

Warning labels on the radiographic table

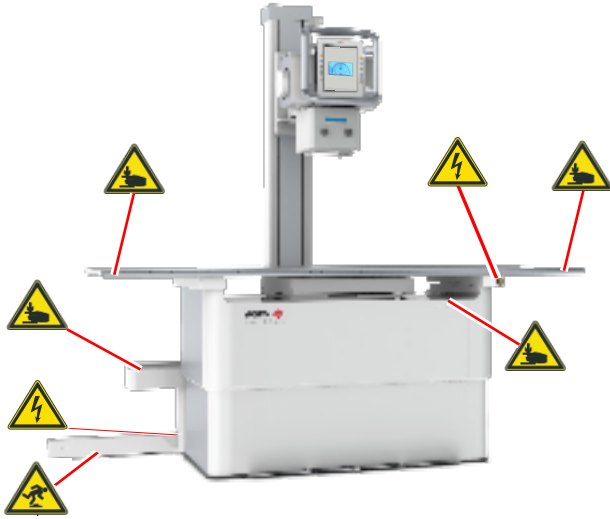

Figure 18: Warning labels on the radiographic table

Warning labels on the radiographic wall stand

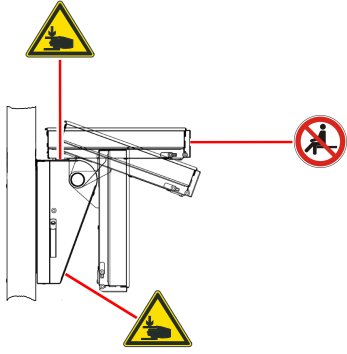



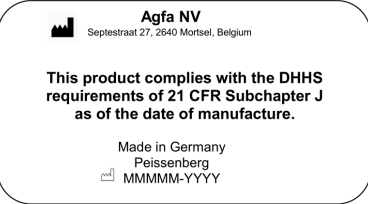

Figure 19: Warning labels on the radiographic wall stand

Type label

Mark	Meaning
 <p>(Sample of subtype 5520/100)</p> <p> Note The CE sign and safety signs are only valid at time of product release.</p>	<p>Type label positioned on the lower left or right hand side of the X-ray tube stand.</p> <p>The type label information for each combination of X-ray tube and X-ray generator is available in the technical data.</p>
	<p>Type B applied part</p>
	<p>The 21 CFR Subchapter J label is positioned close to the type label.</p>

Related information

[DR 400 Technical Data](#) on page 205

DR Detector identification label

Label	Meaning
	Writable label to identify and dedicate a DR Detector to an X-ray system bucky.

Additional Labeling of the radiographic table

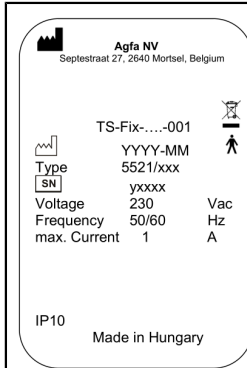

(example of subtypes 5521/100, 5521/110)

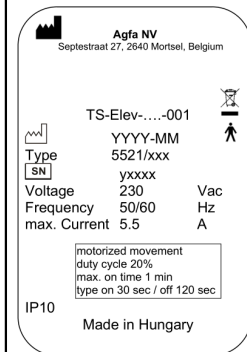

(example of subtypes 5521/200, 5521/210)

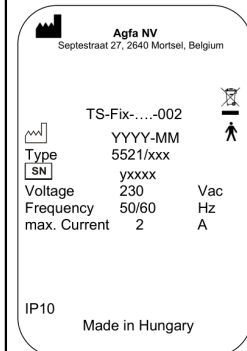

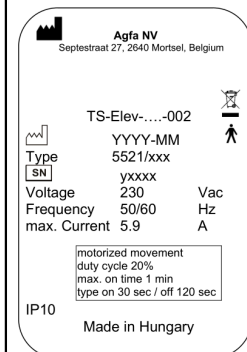

(example of subtypes 5521/300, 5521/310)



(example of subtypes 5521/400, 5521/410)



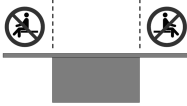







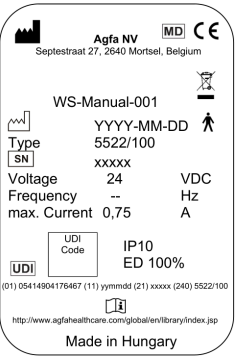



Type label on the lower left or right hand side of the X-ray tube stand.

	Type B applied part
	Top side according to patient orientation to indicate the orientation of the AEC sensors (optional)
	The patient must not sit on the end of the tabletop, since the weight load can lead to table deformations and damage to the product.

Related information

[Radiographic Table and X-Ray Tube Stand Technical Data](#) on page 208

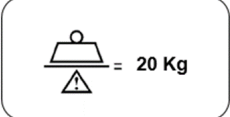





Additional Labeling of the radiographic wall stand

 <p>Agfa NV   Septestraat 27, 2640 Morsel, Belgium</p> <p>WS-Manual-001 </p> <p> YYYY-MM-DD  Type 5522/100</p> <p> xxxxx</p> <p>Voltage 24 VDC Frequency -- Hz max. Current 0,75 A</p> <p> IP10  ED 100%</p> <p> (01) 05414904176467 (11) yyymmdd (21) xxxxx (240) 5522/100 http://www.agfahealthcare.com/global/en/library/index.jsp Made in Hungary</p>	<p>Type label on the lower right hand side of the radiographic wall stand.</p>
	<p>Type B applied part</p>
	<p>Earth (ground)</p>
	<p>Do not sit. The bucky can be tilted to horizontal position. Do not use the bucky as a seat.</p>
	<p>The maximum load for the bucky movement in vertical direction is 20 kg.</p>
	<p>A pinch point label is located on top of the tilting extension.</p>

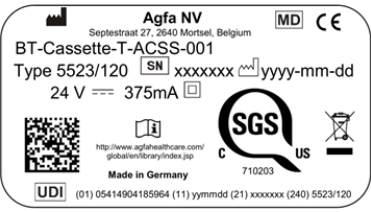
Related information

[Radiographic Wall Stand Technical Data](#) on page 210

Labeling of the bucky

 <p>Figure 20: (Sample of subtype 5523/120)</p>  <p>Figure 21: (Sample of subtype 5523/125)</p>	<p>The type label is located on the rear cover of the bucky or on the bucky drawer below the rotating platform.</p> <p>The type label information for each bucky model is available in the technical data.</p>
	<p>Class II equipment.</p>
	<p>Pinch Points.</p> <p>The label is positioned on the lateral cover of the bucky or on the rotating platform.</p>
	<p>Maximum load capacity is 10 kg on the bucky drawer when it is pulled out. Do not lean or sit on the bucky.</p> <p>The label is positioned on the lateral cover of the bucky or on the rotating platform.</p>
	<p>Refer to instruction manual/booklet.</p> <p>The label is positioned on the lateral cover of the bucky or on the rotating platform.</p>

Related information

[Bucky Unit Technical Data](#) on page 213

Labeling of the Automatic Exposure Control (AEC)

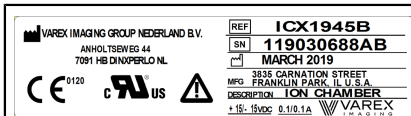
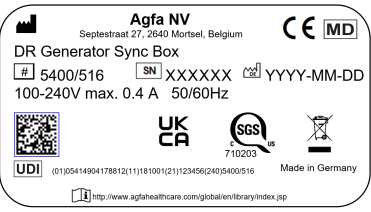



Figure 22: Example of type label

The type label is located on the AEC ionization chamber. The label is not visible without disassembling the component.

Labeling of the DR Generator Sync Box

 <p>Figure 23: Example of type label</p>	<p>The type label is located on the DR Generator Sync Box</p>
	<p>Earth (ground)</p>
	<p>Equipotential connector: Provides a connection between the equipment and the potential bus bar of the electrical system as found in medical environments.</p> <p>It is recommended to use the equipotential connection as additional safety measure.</p>

Labeling of the X-ray generator mini console



If the system has just been stopped, wait at least 10 seconds before starting it again.

Cleaning and Disinfecting

All appropriate policies and procedures should be followed to avoid contamination of the staff, patients and equipment. All existing universal precautions should be extended to avoid potential contaminations and to avoid patients coming into (close) contact with the device. The user is responsible for selecting a disinfection procedure.

- [Cleaning](#) on page 55
- [Disinfecting](#) on page 56
- [Disinfecting safety directions](#) on page 57
- [Approved disinfectants](#) on page 58

Cleaning

To clean the exterior of the equipment:

1. Stop the system



Warning: When the equipment is going to be cleaned, be sure to turn off the main power of the system. Never use anhydrous or high solvency alcohols, benzine, thinner or any other flammable cleaning agent. Otherwise, it may result in fire or electric shock.

2. Wipe the exterior of the system with a cloth slightly moistened with a neutral detergent.



Caution: Make sure no liquid gets in the device.



Caution: Clean the equipment with only a little moisture. Do not spray disinfectants or detergents directly on the equipment. Do not pour liquid directly on the equipment.



Caution:

Do not use solvents such as anhydrous or high solvency alcohols, thinner or benzine. Do not use any corrosive, dissolving or abrasive cleaning or polishing detergents.

Doing so may damage the surface of the equipment. Using unsuitable cleaning agents or methods can damage the property when surface becomes dull and brittle (e.g. by using alcohol-containing agents).



Note Do not open the equipment for cleaning. No components inside the device require cleaning by the user.

3. Start up the system.

Related information

[Stopping the System](#) on page 83

[Starting the System](#) on page 65

Cleaning the tube head display during operation

To clean the tube head display during operation

1. Press and hold the cleaning button for 2 seconds.



Figure 24: Cleaning button

A black screen hides the screen and shows a number counting down.

2. Clean the display.

The operation is not affected.

3. The display can be used again after the countdown has finished.

Disinfecting



Warning: To disinfect the device, use only disinfectants and disinfection methods that are approved by Agfa and that correspond to the national regulation and guidelines as well as explosion protection.

If you plan to use other disinfectants, approval of Agfa is needed before use, as most disinfectants can damage the device. UV disinfection is also not allowed.

Perform the procedure following the instructions for use, the disposal instructions and the safety instructions of the selected disinfectants and tools and of the hospital.

Items contaminated with blood or body fluids, which may contain blood-borne pathogens, should be cleaned and then receive intermediate level disinfection with a product having an EPA-registered claim for activity against hepatitis B.

Disinfecting safety directions



Warning: Using a disinfectant that can form an explosive or flammable gas mixtures is hazardous to life and health because of explosion risk. Switch the equipment off before disinfecting. Allow the gas mixture to evaporate before switching the x-ray system back on.



Caution: Using unsuitable disinfectants can cause discoloration and damage of the surface of the equipment. If a functional degradation or malfunctioning of the product is noticed due to disinfection, contact the medical device manufacturer.

To disinfect the device:

- Do not use any corrosive, soluble or gaseous disinfectants.
- Consult the manufacturer's Material Safety Data Sheets (MSDS) and recommendations on the product label for additional information prior to use.
- Use of spray disinfection can cause malfunctions due to ingress of the disinfectant into the equipment. Disinfect all parts of the unit, including the accessories and connection cables by just wiping them. Switch off the system and cover the cooled system carefully before performing a room disinfection using nebuliser.

Approved disinfectants

Refer to the Agfa website for specifications on the disinfectants that have been found compatible with the cover material of the device and can be used on the outer surface of the device.

<http://www.agfahealthcare.com/global/en/library/overview.jsp?ID=41651138>

Maintenance

Complete maintenance schedules are available in the Agfa service documentation for consultation by an Agfa trained and authorized service engineer.

Maintenance of the DR Detector

The DR Detector requires regular calibration. Calibration instructions are described in the DR Detector Calibration Key User Manual (doc 0134).

- [Maintenance of the radiographic table, radiographic wall stand and X-Ray Tube Stand](#) on page 59

Maintenance of the radiographic table, radiographic wall stand and X-Ray Tube Stand

The X-ray unit and all components require regular maintenance to ensure the equipment is safe and reliable for operation.





-  **Warning:** Operation in unsafe condition includes the risk of radiological exposure and injury of the patient and/or the operator. The customer is responsible to ensure the fault-free condition of the equipment.
-  **Warning:** Wear of equipment due to excessively long intervals between service may lead to personal injury and property damage due to worn and unsafe parts.
-  **Warning:** Incorrect or defective spare parts may adversely affect the safety of the system and lead to damages, malfunctions or total failure. Use only original spare parts provided by the manufacturer.
-  **Warning:** Improper changes, additions, maintenance or repair of the equipment or the software can lead to personal injury, electrical shock and damage to the equipment. Safety is only guaranteed when changes, additions, maintenance or repairs are carried out by an Agfa certified field service engineer. A non certified engineer performing a modification or service intervention on a medical device, acts on his own responsibility and makes the warranty void.

Table 3: Lifetime and maintenance

Lifetime	
Expected lifetime for the X-ray unit	10 years
Periodic maintenance	
The equipment shall have a technical maintenance to maintain fault-free operation and ensure safety for patient and operator.	Every 12 months or after 60.000 cycles, whatever comes first
All steel cables of X-ray tube stand and radiographic wall stand shall be checked	
All steel cables of X-ray tube stand and radiographic wall stand shall be exchanged to maintain fault-free operation and ensure safety for patient and operator	Every 36 months
Replacing the coin cell battery of the X-ray generator	
Perform electrical safety testing according to IEC 62353	
Maintenance by the user	

Check constant smooth movements	Daily
Check ease of movements	Daily
Check secure release and locking of brakes	Daily
Check functioning of operating controls	Daily
Check markers and warning signs	Daily
Warm-up of X-ray tube	Daily
Check all electric cables and connections for damage or broken cables.	Weekly
Conditioning of the X-ray tube	After the X-ray tube has not been used for more than a week
Conditioning of the X-ray tube	Before making exposures using voltages of 120 kV or higher



Caution: In case of functional defects or other deviations from normal operation behavior the unit has to be switched off immediately and the service to be informed. The equipment must only be put back into operation when the fault has been repaired.

Warming-up of X-ray tube

The X-ray tube needs to be warmed-up before making X-ray exposures at the start of each day and when the X-ray tube has not been in use for more than an hour. This extends the X-ray tube life-time.

To warm-up the X-ray tube

1. Close the collimator blades fully
2. Set exposure settings: 70 kV, 100 mAs, 200 mA, 500 ms and large focus
3. Ensure that no one will be exposed
4. Make a total of three exposures, 15 seconds apart

This procedure is used for a typical X-ray tube. Consult the X-ray tube manufacturer instructions for the actual X-ray tube in use and comply with the instructions if there is conflict with this procedure.

Conditioning procedure for the X-ray tube

If the X-ray tube has not been used for more than a week or if exposure techniques are to be used with energies above 120 kV, it is recommended to perform the conditioning procedure for the X-ray tube.

A sequence of gradually increasing loads on the X-ray tube will cause a redistribution of the electrical charges inside the tube, which in turn will result in a stable output of the tube.

The procedure takes approximately 30 minutes.

1. On the software console, select the manual modality position.
No image will be acquired on the NX workstation.



2. Select the three point radiographic working mode.



3. Set the radiographic parameters to 125 mA (current) and 100 ms (exposure time).
4. Select the large focal spot.



5. Take a sequence of exposures with the following kV values. Take one exposure per 30 seconds.











Table 4: Sequence of exposures

Time (minutes)	kV	Time (minutes)	kV	Time (minutes)	kV
0.0	50	4.0	90	8.0	130
0.5	50	4.5	90	8.5	130
1.0	60	5.0	100	9.0	140
1.5	60	5.5	100	9.5	140
2.0	70	6.0	110	10.0	150
2.5	70	6.5	110	10.5	150
3.0	80	7.0	120		
3.5	80	7.5	120		











Safety Directions

- [General Safety Directions](#) on page 62
- [Safety Directions for the X-Ray System](#) on page 63
- [Safety Directions for the radiographic table](#) on page 64







General Safety Directions

-  **Warning:** Safety is only guaranteed when an Agfa certified field service engineer has installed the product.
-  **Warning:** The product must only be installed using released components and in released configurations.
-  **Warning:** To avoid risk of electric shock, this equipment must only be connected to a supply mains with protective earth.
-  **Warning:** Ionizing radiation can lead to radiation injuries if handled incorrectly. When radiation is applied, the required protective measures must be complied with.
-  **Warning:** The operator must take precautions to protect himself against dangerous X-ray exposure when using the DR detector in the X-ray beam path of an X-ray source.
-  **Warning:** The DR Detector is not intended to be used as a primary barrier to X-rays. The user is responsible for ensuring the safety of the operator, bystanders, and the subjects being radiographed.
-  **Warning:** Operating the equipment when it is faulty includes the risk of radiological exposure and injury to the patient and to the operator. Operate the equipment only in safe and fault-free conditions.
-  **Warning:** System unavailability due to hardware or software failure. If the product is used in critical clinical workflows, a backup system has to be foreseen.
-  **Caution:** Strictly observe all warnings, cautions, notes and safety markings within this document and on the product.
-  **Caution:** All Agfa medical products must be used by trained and qualified personnel.

Safety Directions for the X-Ray System

-  **Warning:** Avoid unnecessary dose by checking the workstation selection on the X-ray generator console before exposing.
-  **Warning:** Repeated exposures to a patient with high doses can lead to deterministic effects. Therefore exposure settings shall be selected carefully and in accordance to the patient and the object to expose and balanced in such a way that patient dose is as low as possible while image quality is usable for diagnosis.
-  **Warning:** Even if the generator is switched off, parts on the inside of the generator cabinet and connected controls are still powered! Ensure that only trained service personnel open the generator cabinet and the housing of connected devices! Improper handling may cause a lethal hazard!
-  **Caution:** Avoid unnecessary dose by checking before exposure if the DR Detector Switch displays the name of the DR Detector that is being used and if the status of the DR Detector is ready for exposure.
-  **Caution:** When operating the DR detector, the calculated exposure time (ms) or manual overrides should never exceed the maximum exposure time (Max ms) specified as integration time of the DR detector.
-  **Caution:** Damaged grid. Reduced image quality. Please handle the grids with special care.
-  **Caution:** When inserting the anti-scatter grids, it is essential that the grid corresponds to the intended source-image-distance (SID) to which the grid is focussed. Because of the focussing of the grids, the tube head unit must be centered onto the bucky.
-  **Caution:** Excessive ambient temperature may impact performance of DR Detectors and cause permanent damage to the equipment. Refer to the related user manual for environmental conditions for the DR detector. If ambient temperature and humidity is outside the specified range, do not operate the system or use air conditioning. Frost due to low temperatures can damage internal circuits. Warranty will be void if it is obvious that operating conditions are not met.
-  **Caution:** To avoid images being lost due to a power failure, the workstation and the Digitizer have to be connected to uninterruptable power supply (UPS) or an institutional standby generator. In case of a power failure, the UPS will allow to finalize exposed images that are being scanned.
-  **Caution:** Install the NX workstation and CR digitizer at a minimum (safe) distance of 2 m from the X-Ray System components or provide a wall or window to separate both systems.

Safety Directions for the radiographic table

-  **Warning:** The system is not intended for operation in explosion-prone areas. Such an operation is hazardous to life and health because of explosion risk. Please note the applicable regulations on formation of explosive gas mixtures when cleaning and using in combination with patients.
-  **Warning:** Unauthorized manipulation or opening of the equipment housing may lead to personal injuries and to property damage. Take all necessary precautions with respect to the applicable level of safety.
-  **Warning:** The system is installed with components that emit radiation or can be triggered to emit radiation. Ionizing radiation can result in radiation damage or injury if not handled properly.
-  **Warning:** Portable and mobile HF communication devices may affect medical electrical equipment.
-  **Caution:** Using soft covers, sheets, mattresses, etc. may lead to visual image artifacts. If such shall be used, make sure that they are x-ray transparent and do not influence image quality.
-  **Caution:** Make sure that the patient hand grips are securely mounted.

Basic Workflow

- [Starting the System](#) on page 65
- [Performing an exposure using the DR Detector](#) on page 67
- [Performing an exposure using a CR cassette](#) on page 73
- [X-Ray System Positioning](#) on page 78
- [Stopping the System](#) on page 83
- [Guidelines for pediatric applications](#) on page 84

Starting the System

Allow the DR detector to warm up before the system is used for clinical purposes. The warming-up time starts as soon as the DR detector has been powered on and the MUSICA Acquisition Workstation is running. To check if a warming-up time is required, refer to the DR detector technical data.

For using the fixed DR Detector, the temperature difference between calibration and usage must be within the recommended range of $\pm 6^{\circ}\text{C}$ (for a DR Detector with CsI conversion screen) or $\pm 10^{\circ}\text{C}$ (for a DR Detector with GOS conversion screen). Check the environmental conditions and observe the warming-up time of the DR Detector.

To start the system:

1. Switch on the electrical room switch.
Check that neither the emergency shutdown power switch for the system nor any of the emergency stop buttons for the radiographic table is activated.
2. Press the Power ON button on the X-ray generator mini console to switch on the system.
3. Start the MUSICA Acquisition Workstation.

For detailed information, refer to the MUSICA Acquisition Workstation User Manual, document 4420.

The NX application and the software console are available on the MUSICA Acquisition Workstation.

4. Switch on the DR Generator Sync Box (if applicable).
5. In a configuration with a wireless DR detector, power on the DR detector:
 - a) attach a fully charged battery pack to the DR detector.
 - b) turn on the DR detector.
 - c) if needed, register the DR detector to the MUSICA Acquisition Workstation.

For detailed information about starting up the DR detector, refer to the DR Detector User Manual.

6. In a configuration with a wired DR detector, switch on the control unit for the DR detector.
 - [Automated workflow for warming-up of X-ray tube](#) on page 65

Related information

[Technical Data](#) on page 204

Automated workflow for warming-up of X-ray tube

The software console provides an automated workflow for warming-up of the X-ray tube.

1. Close the collimator blades fully.
2. Make sure that no one will be exposed.
3. On the software console, go to the screen with modality controls.



Figure 25: Navigation button for modality controls

4. Click the button to start the automated workflow for warming-up of the X-ray tube.

Figure 26: Button to start the automated workflow for warming-up of the X-ray tube



A table is displayed with a list of exposures.

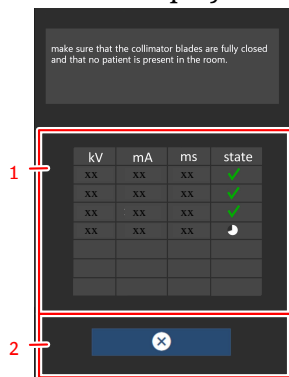

1. Table with list of exposures
2. Button to cancel the warming-up procedure

Figure 27: List of exposures for warming-up of the X-ray tube

5. Make sure that the collimator blades are fully closed and that no patient is present in the room. To avoid radiation on a DR detector, remove the detector, turn the tube away from the detector, or cover the detector with a lead apron.
6. Perform the exposures and wait for the timer icon to finish between exposures. The exposure parameters are set automatically.

Performing an exposure using the DR Detector

- [Step 1: retrieve the patient info](#) on page 68
- [Step 2: select the exposure](#) on page 69
- [Step 3: prepare the exposure](#) on page 70
- [Step 4: check the exposure settings](#) on page 71
- [Step 5: execute the exposure](#) on page 72
- [Step 6: perform a quality control](#) on page 72

Step 1: retrieve the patient info

At the MUSICA Acquisition Workstation:

1. When a new patient comes in, define the patient info for the exam.
2. Start the exam.

If the workstation is connected to a second monitor that is positioned outside the operator room, make sure that the patient data is not exposed to unauthorized persons.

Step 2: select the exposure

In the operator room:

At the NX workstation, select the thumbnail for the exposure in the **Image Overview** pane of the **Examination** window.

The default X-Ray exposure parameters for the selected exposure are sent to the modality and displayed on the software console.

The selected DR Detector is activated.

The DR Detector Switch shows which DR detector is active and shows its status.

- Flashing: starting up
- Green (constant): ready for exposure

The radiographic table or radiographic wall stand lights up in blue, indicating the selected modality position.

Step 3: prepare the exposure

In the examination room:

1. Position the DR Detector.

When using the bucky, check that the identification labels on the DR Detector and on the bucky match. Do not use a DR Detector that is dedicated to another bucky.

2. Position the patient.

Apply radiation protective measures for the patient if needed.

3. Check if the X-Ray system position is suitable for the exposure.

4. Position the X-Ray tube with respect to the DR Detector and the patient.

5. Set the correct distance between DR Detector and X-Ray tube.

6. Switch on the light on the collimator. Adapt collimation if required.

Take care that the collimated area is not larger than the detector.



Warning: Monitor the patient position (hands, feet, fingers, etc.) with special care to avoid injury to the patient caused by unit movements. Patient hands must be kept away from mobile components of the unit. Intravenous tubing, catheters and other patient connected lines should be routed away from moving equipment.

Step 4: check the exposure settings

Related information

[DR Detector Switch](#) on page 23

On the NX application:

1. Check if the DR Detector Switch displays the name of the DR Detector that's being used
2. If a wrong DR Detector is displayed, select the right DR Detector by clicking the drop down arrow on the DR Detector Switch.

On a DR Detector that has a status indicator:

Check if the status of the DR Detector is ready for exposure. If the status is not ready for exposure, the DR Detector cannot be used for making an exposure.

On the Software Console:

1. Check if the exposure settings displayed on the console are suitable for the exposure.
If other exposure values are required than those defined in the NX exam, use the console to overwrite the default defined exposure settings.
2. Check if the status of the DR Detector is ready for exposure.

Step 5: execute the exposure

In the operator room:

Press the exposure button to execute the exposure.



Make sure the generator is ready for exposure before you press the exposure button.



Warning: During exposure ionizing radiation is emitted by the X-ray system. To indicate the presence of ionizing radiation, the radiation indicator on the control console lights up.



Warning: Do not select another thumbnail until the preview image is visible in the active thumbnail.

In the operator room at the NX workstation:

- The image is acquired from the DR detector and displayed in the thumbnail.
- The actual X-Ray exposure parameters are sent back from the generator to the NX workstation and are shown in the Image Detail pane.
- If collimation is applied, the image is automatically cropped at the collimation borders.

Step 6: perform a quality control

At the MUSICA Acquisition Workstation:

1. Select the image on which quality control is to be performed.
2. Prepare the image for diagnosis by using e.g. L/R markers or annotations.
3. If the image is OK, send the image to a hardcopy printer and/or PACS (Picture Archiving and Communication System).

Performing an exposure using a CR cassette



Note Using an ID Tablet to identify cassettes before the exposure will break the communication of X-ray parameters between the NX workstation and the X-ray generator console. It is advised to identify cassettes after the exposure, as described in this workflow.

- [Step 1: retrieve the patient info](#) on page 68
- [Step 2: select the exposure](#) on page 75
- [Step 3: prepare the exposure](#) on page 76
- [Step 4: check the exposure settings](#) on page 76
- [Step 5: execute the exposure](#) on page 77
- [Step 6: repeat steps 2 to 5 for the next subexposures](#) on page 77
- [Step 7: digitize the image](#) on page 77
- [Step 8: perform a quality control](#) on page 77

Step 1: retrieve the patient info

At the MUSICA Acquisition Workstation:

1. When a new patient comes in, define the patient info for the exam.
2. Start the exam.

If the workstation is connected to a second monitor that is positioned outside the operator room, make sure that the patient data is not exposed to unauthorized persons.

Step 2: select the exposure

In the operator room at the NX workstation:

1. Select the thumbnail for the exposure in the Image Overview pane of the Examination window.
2. Select CR in the Detector Switch.
3. Select the Modality Position (radiographic table, radiographic wall stand, free exposure) in the Software Console.

The default X-Ray exposure parameters for the selected exposure are sent to the modality and displayed on the software console.

The radiographic table or radiographic wall stand lights up in blue, indicating the selected modality position.

4. Select the subexposure if more than one image is required for the same cassette.
If an image thumbnail is configured for multiple exposures on a single cassette, another set of thumbnails is shown in the image detail pane. Now you have to select one of these thumbnails to send the proper default X-Ray exposure parameters to the modality for each exposure.



Note When working in a PACS environment, the preferred workflow is to have only one image per cassette. This is needed for optimal use of hanging protocols. However, in particular cases (e.g. printing sites) it is supported to make more than one exposure per cassette.

Step 3: prepare the exposure

In the examination room:

1. Position the cassette.



Note For a free exposure, partial lead covering of the cassette may be required if multiple images are taken on one cassette.



Note For a bucky exposure, always insert an unexposed cassette in the bucky.

2. Position the patient.

Apply radiation protective measures for the patient if needed.

3. Check if the X-Ray system position is suitable for the exposure.
4. Position the X-Ray tube with respect to the cassette and the patient.
5. Set the correct distance between cassette and X-Ray tube.
6. Switch on the light on the collimator. Adapt collimation if required.

Take care that the collimated area is not larger than the cassette.



Warning: Monitor the patient position (hands, feet, fingers, etc.) with special care to avoid injury to the patient caused by unit movements. Patient hands must be kept away from mobile components of the unit. Intravenous tubing, catheters and other patient connected lines should be routed away from moving equipment.

Step 4: check the exposure settings

In the operator room on the Software Console:

1. Check if the exposure settings displayed on the console are suitable for the exposure.
2. Check the Ready for Exposure status.

Step 5: execute the exposure

In the operator room:

Press the exposure button to execute the exposure.



Warning: During exposure ionizing radiation is emitted by the X-ray system. To indicate the presence of ionizing radiation, the radiation indicator on the control console lights up.

- The actual X-Ray exposure parameters are sent back from the generator to the NX workstation and are shown in the Image Detail pane.
- The actual X-Ray exposure parameters and the Exposure Index (EI) value on the NX workstation can be used to monitor the performance of the Automatic Exposure Control of the X-Ray system.
- A green OK mark appears on all thumbnails for which the exposures are made and for which exposure settings are sent back to the NX workstation.

Step 6: repeat steps 2 to 5 for the next subexposures

Step 7: digitize the image

In the examination room:

Take the exposed cassette.

In the operator room:

1. Insert the cassette in the digitizer.
2. Click ID in the examination window of NX.



Note You can also use an ID Tablet to identify the cassette and digitize it using any digitizer.

The image will appear in the image overview pane of the examination window.

Step 8: perform a quality control

In the operator room at the NX workstation:

1. Select the image on which quality control is to be performed.
2. Prepare the image for diagnosis by using e.g. L/R markers or annotations.
3. If the image is OK, send the image to a hardcopy printer and/or PACS (Picture Archiving and Communication System).

X-Ray System Positioning

- [Radiographic table exposures](#) on page 79
- [Oblique Exposures](#) on page 80
- [Lateral Exposures](#) on page 81
- [Radiographic wall stand exposures](#) on page 82

Radiographic table exposures

1. Position the patient on the radiographic table.
2. Position the X-ray tube stand with the X-ray tube over the patient.
The bucky is automatically aligned to the X-ray tube by mechanical coupling.
3. Center the examined body part over the bucky using the floating table top.

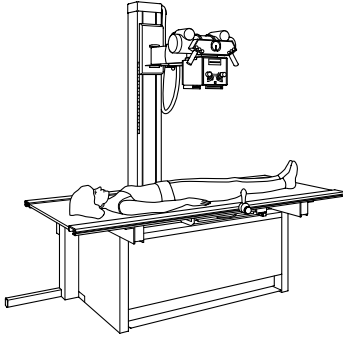

Figure 28: radiographic table exposures

Oblique Exposures

1. Position the patient on the radiographic table.
2. Move the X-ray tube stand out of the coupling range of the bucky.
3. Position the bucky under the patient.
4. Set the required angle of the X-ray tube.
5. Adjust the position of the X-ray tube stand to align the X-ray exposure field to the center of the bucky using the collimator light and the bucky markers for orientation.

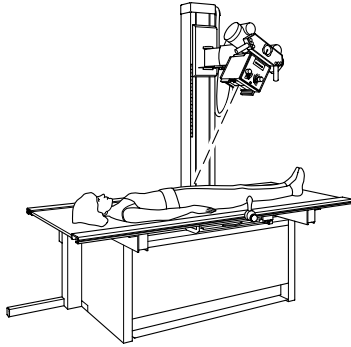

Figure 29: Oblique Exposures

Lateral Exposures

1. Unlock the X-ray tube arm and rotate 90° around.
2. Rotate the X-Ray tube 90° around.
Check the angle on the angle display.
3. Mount the lateral cassette holder on the side rail of the tabletop. Fix it using the two lower screws. Take care to lift the holders slightly up when moving it, to protect the tabletop from scratching.
4. Insert a cassette or a DR detector. Fix it using the upper screw.
5. Position the patient on the table between the X-ray tube and the lateral cassette holder. Adjust the lateral cassette holder to position the cassette as close as possible to the patient. Fix the position using the middle screw.

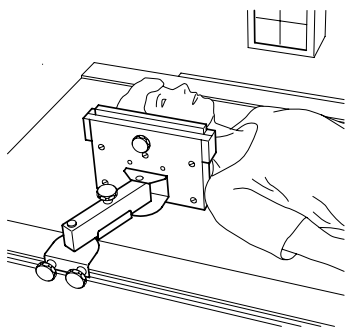

Figure 30: Lateral Exposures

Radiographic wall stand exposures

1. Adjust the height of the bucky on the radiographic wall stand.
2. Position the patient in front of the radiographic wall stand.
3. Move the table top away from the radiographic wall stand.
4. Rotate the X-ray tube 90° to face the radiographic wall stand.
Check the angle on the angle display.
5. Move the X-ray tube stand towards the radiographic wall stand.
6. Adjust the height of the X-ray tube to center the X-ray exposure field on the bucky using the collimator light.

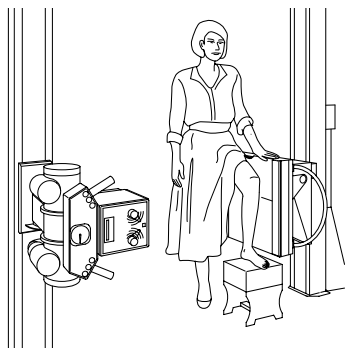

Figure 31: Radiographic wall stand exposures

Stopping the System

To stop the system:

1. Stop the MUSICA Acquisition workstation.

The MUSICA Acquisition workstation can be stopped in two ways, either by logging out of Windows or without logging out of Windows.

For detailed information, refer to the MUSICA Acquisition workstation User Manual, document 4420.



Note Stopping the NX workstation does not stop the DR detector. If the power of the DR detector remains on, no warming-up time will be needed after starting the MUSICA Acquisition workstation.

2. Press the Power OFF button on the X-ray generator mini console to switch off the generator.
3. In a configuration with a wireless DR detector, power off the DR detector:
 - turn off the DR detector.
 - remove the battery pack.
 - charge the battery.
4. Switch off the DR Generator Sync Box.



Note If the DR detector is powered down, a warming-up may be required on the next start-up.



Warning: If the system has just been stopped, wait at least 10 seconds before starting it again.

Guidelines for pediatric applications



Caution: Use special care when imaging patients outside the typical adult size range.

Children are more radiosensitive than adults. Reducing dose for radiographic procedures while maintaining acceptable clinical image quality will benefit patients. The user documentation of this product contains a set of guidelines for pediatric applications, applicable in the U.S.A. Refer to document "Exposure Techniques for pediatric and adult use with DR 400".

- [Guidelines for Pediatric Applications](#) on page 84

Guidelines for Pediatric Applications



Caution: Use special care when imaging patients outside the typical adult size range. Children are more radiosensitive than adults.

Reducing dose for radiographic procedures while maintaining acceptable clinical image quality will benefit patients.

Adopting the Image Gently campaign guidelines and reducing dose for radiographic procedures while maintaining acceptable clinical image quality will benefit patients. Please review the following link and reduce pediatric technique factors accordingly: <http://www.imagegently.org>

As a general rule, next recommendations shall be observed in pediatrics:

- X-Ray Generator must have short exposures times.
- AEC must be used carefully, preferably use manual technique setting, applying lower doses.
- If possible, use high kVp techniques.

Positioning the pediatric patient: Pediatric patients are not as likely as adults to understand the need to remain still during the procedure. Therefore it makes sense to provide aids to maintaining stable positioning. It is strongly recommended the use of immobilizing devices such as bean bags and restraint systems (foam wedges, adhesive tapes, etc.) to avoid the need of repeating exposures due to the movement of the pediatric patients. Whenever possible use techniques based on the lowest exposure times.

Shielding: We recommend you provide extra shielding of radiosensitive organs or tissues such as eyes, gonads and thyroid glands. Applying a correct collimation will help to protect the patient against excessive radiation as well. Please review the following scientific literature regarding pediatric radiosensitivity: GROSSMAN, Herman. "Radiation Protection in Diagnostic Radiography of Children". *Pediatric Radiology*, Vol. 51, (No. 1): 141–144, January, 1973:

<http://pediatrics.aappublications.org/cgi/reprint/51/1/141>.

Technique factors: You should take steps to reduce technique factors to the lowest possible levels consistent with good image acquisition and to limit the duration of fluoroscopy sequences and rapid sequences.

For example if your adult abdomen settings are: 70–85 kVp, 200–400 mA, 15–80 mAs, consider starting at 65–75 kVp, 100–160 mA, 2.5–10 mAs for a pediatric patient. Whenever possible use high kVp techniques and large SID (Source Image Distance).

Summary:

- Image only when there is a clear medical benefit.
- Image only the indicated area.
- Use the lowest amount of radiation for adequate imaging based on size of the child (reducing tube output – kVp and mAs, limiting the duration of dynamic imaging).
- Try to use always short exposure times, large SID values and immobilizing devices.





- Avoid multiple scans and use alternative diagnostic studies (such as ultrasound or MRI) when possible.

Software Console and Tube Head Display

The software console is displayed on the NX workstation.

On a configuration with tube head display, the software console is displayed on the tube head display as well. The arrangement and availability of the controls may be different.

Table 5: Navigation

Navigation button	Software console screen
	Examination overview
	Generator controls
	X-ray modality controls
	System messages

- [Cleaning the tube head display](#) on page 86
- [Planned exposures](#) on page 87
- [X-ray image preview screen](#) on page 88
- [Main screen of the Tube head display](#) on page 89
- [X-ray modality status frame](#) on page 94
- [Generator screen](#) on page 102
- [X-ray modality screen](#) on page 112
- [System messages screen](#) on page 113

Cleaning the tube head display



Figure 32: Button to clean the tube head display during operation

Press and hold the cleaning button for 2 seconds.

Planned exposures

By clicking the status bar, an overview is displayed of the exposures that still have to be taken for the examination.

Select an exposure to load the default X-ray exposure parameters and to activate the selected DR Detector.

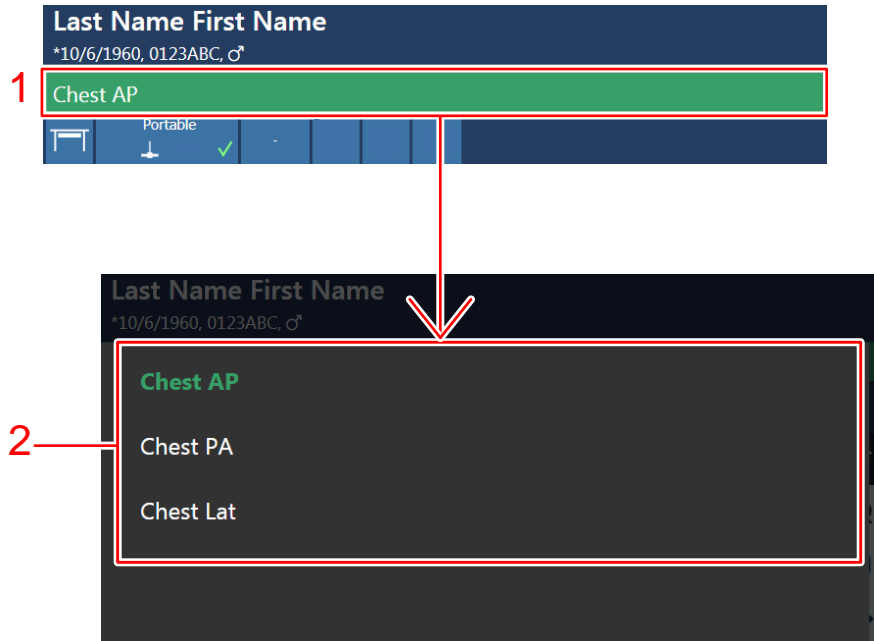

1. Status bar
2. Overview of exposures

Figure 33: Examination overview window

X-ray image preview screen

After an exposure, the acquired image is displayed on the tube head display.

To return to the controls, push the display anywhere.

To disable image preview, toggle the **Image preview** button.

The default setting is configurable.



Main screen of the Tube head display

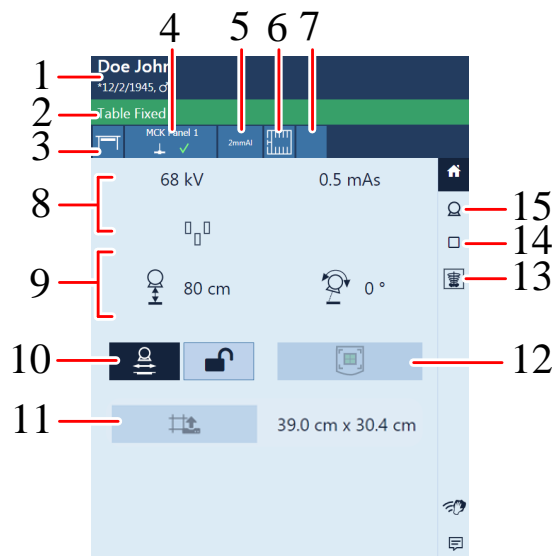



1. Patient information
2. Status bar with exam type
3. Modality position
4. DR Detector Switch
5. Filter status
6. Grid status
7. Collimator status
8. Radiographic parameters
9. Position parameters
10. Position tracking
11. Collimation controls (for automatic collimator)
12. Automatic centering
13. Image preview
14. X-ray modality controls
15. Generator controls

Figure 34: Example of the tube head display

- [Position parameters](#) on page 90
- [X-ray tube stand tracks table height](#) on page 91
- [X-ray tube stand tracks wall stand height](#) on page 92
- [Collimator Parameters](#) on page 93

Position parameters

Table 6: Position parameters

	Source image distance (SID) No value is displayed for free exposures or if the X-ray tube is not pointing to the selected DR detector.
	X-ray tube tilting angle (alpha) Windmill movement

X-ray tube stand tracks table height

To keep constant SID while adjusting table height:

1. Set the required SID by adjusting the position of the X-ray tube stand.
The distance between the X-ray tube head and the table top must not be less than 50 cm.
2. On the tube head display, press the position tracking button.



Figure 35: Table position tracking disabled and enabled

The button is highlighted.



3. Adjust the table height.
The X-ray tube stand is moving up or down accordingly.



Note The movement of the X-ray tube stand has a small delay compared to the movement of the table. The movement of the X-ray tube is automatically stopped if the distance between the X-ray tube head and the table would become too small (SID lower than 45 cm).

The **lock** button controls the behaviour of the position tracking after the exposure is made.

Table 7: Locking the position tracking

	<p>Position tracking is not active for the next exposure. It can be activated again by pressing the position tracking button.</p>
	<p>Position tracking is kept active for the next exposure.</p>

X-ray tube stand tracks wall stand height

To keep constant position of the tube head unit relative to wall stand bucky while adjusting wall stand height:

1. Set the required position of the X-ray tube stand.

The distance between the X-ray tube head and the table top must not be less than 15 cm.

Position the X-ray tube head and the table top such that they do not collide when the X-ray tube stand moves up or down.

2. On the tube head display, press the position tracking button.



Warning: Do not use position tracking while the patient is lying on the table.



Figure 36: Wall stand position tracking disabled and enabled

The button is highlighted.

3. Adjust the wall stand height.



The X-ray tube stand is moving up or down accordingly.



Note The movement of the X-ray tube is automatically stopped if the distance between the X-ray tube head and the table top would become too small (less than 10 cm).

The **lock** button controls the behaviour of the position tracking after the exposure is made.

Table 8: Locking the position tracking

	<p>Position tracking is not active for the next exposure. It can be activated again by pressing the position tracking button.</p>
	<p>Position tracking is kept active for the next exposure.</p>

Related information

[Collision indicator](#) on page 120

[Emergency stop button](#) on page 29



Collimator Parameters

On systems with an automatic collimator, the collimation is automatically set, based on the selected exposure.

To use the same collimation setting on subsequent exposures, push the restore button to restore the collimation setting of the previous exposure.

The collimator parameters are available on the main screen of the tube head display.

Table 9: Collimator settings

Icon	Description
	Readout of the actual collimation setting.
	Restore the collimation setting of the previous exposure.

X-ray modality status frame

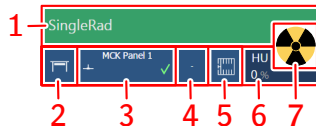



1. Ready for exposure status
2. Modality position
3. DR detector switch
4. Filter status
5. Grid status
6. Heat units
7. Radiation status

Figure 37: X-ray modality status frame

- [Ready for exposure status](#) on page 95
- [Modality Position](#) on page 96
- [DR Detector Switch](#) on page 23
- [Filter Status](#) on page 98
- [Anti-scatter grid status](#) on page 99
- [Radiation status](#) on page 100
- [Unknown status](#) on page 101

Ready for exposure status

Table 10: Exposure ready





Color	Description
	Green Exposure ready. Indicates that the selected technique is properly set and there are no interlock failures or system faults.
	Red Exposure not ready. Check the message frame for more information. It is not possible to perform an exposure due to an error. The status will turn to green when problem is solved.
	Blue Exposure not ready. No examination defined.

Modality Position

The modality position is automatically selected, based on the selected exposure.

To modify the position on the modality where the exposure will be made, click the drop-down arrow and select the modality position from the list.

Table 11: Modality Position

Icon	Description
	The image is planned for the radiographic table.
	The image is planned for the radiographic wall stand.
	The image is planned as a free exposure.
	A manual X-ray exposure can be made. No image will be acquired on the NX workstation.

The type and configuration of the X-ray system defines which modality positions are available.

The available workstations depend on the modality type and configuration.

DR Detector Switch

The DR Detector Switch shows which DR Detector is active and shows its status. The DR Detector Switch can be used to activate another DR Detector. The DR Detector Switch can be switched to CR, depending on the configuration.

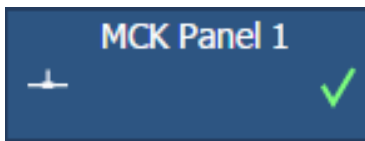

Figure 38: DR Detector Switch

DR detector status

Table 12: Status of the battery





Battery status icon					
Meaning	Full	Medium	Low	Empty	Charging

Table 13: Status of the network connection









Connection status icon (wifi/wired)				
Meaning	Strong	Normal	Weak	Wired DR Detector

Table 14: Status of the DR detector

DR detector status icon		 (blinking)			
Meaning	Ready	Initializing exposure	Error	Sleep	One DR detector must be selected

Filter Status

On systems with automatic filtering, the filter is automatically set, based on the selected exposure. The filter setting can be modified on the software console or on the collimator.

- on the software console, click the filter status drop-down arrow and select the filter from the list.
- on the collimator, use the filter button

Table 15: Collimator with automatic filter



(no icon)	No filter is used.
0.1 mm Cu 1 mm Al	A filter is used. Material and thickness of the filter are specified.

Table 16: Collimator with manual filter

(no icon)	No filter is required.
	A filter is required. Insert the filter manually.

Anti-scatter grid status

Table 17: Grid status - automatically detected

(no icon)	No grid is required.
	The correct grid type is inserted.
	The correct grid type is not inserted. A grid is inserted, but no grid is required. The SID does not correspond to the inserted grid.
	The grid is inserted wrongly.



The focal distance of the grid that is detected in the bucky, is displayed inside the icon.

Table 18: Grid status - not automatically detected

(no icon)	No grid is required.
	A grid is required.

Radiation status

Table 19: Radiation status

	The X-ray tube is prepared.
	After pressing the exposure button completely, the X-ray exposure is made. The indicator on the console will light up.
	The examination room door is open.

Press the exposure button halfway (“Prep” position) to prepare the X-ray tube for exposure. The indicator will light up when the X-ray tube is prepared and there are no interlock failures or system faults.

After pressing this push-button, the following functions are activated:

- Anode rotation.
- Filament current switches from stand-by to the selected mA.

Unknown status

If a status is unknown, a question mark icon is displayed:

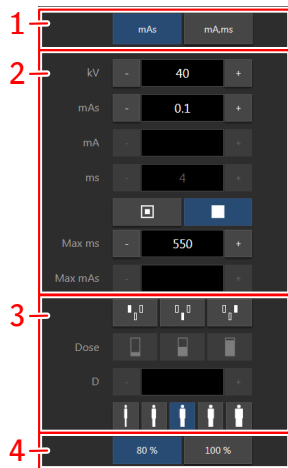

Figure 39: Unknown status

Depending on the component for which the unknown status is displayed, an action is required on the component or on the software to provide the system with the missing information.

E.g. to solve the unknown detector status, one DR detector must be selected.

Generator screen



1. Radiographic working mode
2. Radiographic parameters
3. Automatic exposure control
4. X-ray tube load

Figure 40: Operation screen on the software console

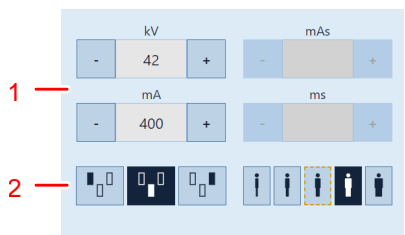

1. Radiographic parameters
2. Automatic exposure control

Figure 41: Operation screen on the tube head display

To change a value, use the + and - buttons. The values increase or decrease step by step each time the corresponding button is pushed. To change a value without repeatedly pushing the buttons, push the value twice. The buttons change into **fast-forward** and **fast-backward** buttons. Push and hold the button to change the value.

After exposure all values reflect the settings actually used by the generator.



The tube head display only has a subset of the generator controls.

- [One point, two point and three point working modes](#) on page 103
- [Radiographic Parameters](#) on page 104
- [Focal Spot Indicator](#) on page 105
- [Automatic Exposure Control \(AEC\)](#) on page 106
- [X-ray tube load](#) on page 109
- [DAP Value](#) on page 110
- [Heat Units](#) on page 111

One point, two point and three point working modes

You can select following radiographic working modes according to the parameters to be controlled and the degree of automation:

Table 20: Radiographic working modes

	One point mode, by selecting kV. The exposure is controlled by AEC.
	Two point mode, by selecting kV and mAs. AEC is disabled.
	Three point mode, by selecting kV, mA and exposure time independently. AEC is disabled.

To switch to one point mode, activate one or more AEC fields.

Depending on the radiographic working mode, some of the generator controls will be disabled.

One Point Mode (1P)

By selecting one of the AEC field buttons, the one point mode is activated.

The value of kV, mA, max ms, max mAs, the setting of focal spot, density, dose, patient size and the selected AEC fields can be adjusted.

The value for mAs and ms is not available.

For accurate AEC operation it may be needed to lower the mA value in order to obtain longer exposure times. The smallest exposure step is 1 ms.

Disabling all AEC fields will switch to two point mode.

After exposure all values reflect the settings actually used by the generator.

Two Point Mode (2P)

The value of kV, mAs, max ms, the setting of focal spot and X-ray tube load can be adjusted.

The value of mA and ms are adjusted automatically to keep the mAs value constant, within the boundaries of generator or X-ray tube limitations.

The setting of density, dose and patient size is not available.

By selecting one of the AEC field buttons, the one point mode is activated.

By adjusting the value of mA or ms, the three point mode is activated.

After exposure all values reflect the settings actually used by the generator.

Three Point Mode (3P)

The value of kV, mA and ms can be adjusted. The other values are adjusted automatically to keep the mAs value constant.

Radiographic Parameters

You can set up following radiographic parameters:



- **kV**: shows the radiographic kV value (X-ray tube voltage) selected for the exposure.
- **mAs** can show:
 - The radiographic mAs value selected for the exposure.
 - When an exposure is made, it shows the actual mAs at the end of the exposure.
- **mA**: shows the radiographic mA value (current) selected for the exposure.
- **ms** can show:
 - The time value (in milliseconds) selected for the exposure.
 - When an exposure is made, it shows the actual time at the end of the exposure.
- **Detector ms** shows the integration time of the DR detector. When operating the DR detector, the calculated exposure time (ms) or manual overrides can never exceed the integration time (detector ms) of the DR detector.
- **Max mAs** shows the maximum allowed mAs value for exposures using AEC. The highest allowed setting for max mAs depends on the mA setting and the detector ms setting. Not available in Free Exposure mode using DR or Free Exposure mode using CR.

When using AEC, the exposure is terminated by the detector ms or max mAs settings, even if the target dose is not reached.

Focal Spot Indicator

A focal spot indicator shows the selected focal spot of the X-ray tube: “Small” or “Large”.

Table 21: Focal Spot Indicator

	Small
	Large

If you change the focal spot, the kV and mAs are kept constant. When changing from a large to smaller focal spot, exposure time may increase as the mAs is kept constant but the mA may be reduced automatically according to the performance of the tube.

Automatic Exposure Control (AEC)

Automatic Exposure Control (AEC) produces consistent detector dose regardless of the radiographic technique selected and of the patient size. The AEC module comprises the controls for the selection of the exposure detector fields (ionization chamber), S-value and density compensation.

To activate AEC mode, touch any of the three AEC field buttons.



To deactivate AEC mode, touch all the selected AEC field buttons until none of them is selected.

AEC field selection

Each button indicates its related physical location of the selected field in the AEC exposure detector, and you may select or deselect it by touching it.

Any combination of fields can be selected and the color of the buttons changes (highlighted) when active. The exposure is ended if any of the selected fields measures the AEC cut-off dose.



Table 22: AEC field selection

	Left field
	Middle field
	Right field

Sensitivity (S-value)

Each of these buttons allows adjustment of the AEC cut-off dose (low dose, middle dose and high dose: depending on configuration at installation time). Each time a button is selected (highlighted), the others are automatically deselected.

Table 23: Automatic filter

S	
	low dose
	middle dose
	high dose

Density

These buttons are used to adjust the AEC cut-off dose (and patient entrance dose accordingly).

Density can be increased and decreased in a range of -4 to +4. Each step is a change of one exposure step. An exposure step is a change of approximately -20% or +25% in dose. When disabled, the density range number appears in black.

Table 24: Dose variation compared to reference dose

Density	Dose
-4	0.41
-3	0.51
-2	0.64
-1	0.80
0	1 (reference dose)
+1	1.25
+2	1.56
+3	1.95
+4	2.44

Patient Size

The size of the patient is classified in five categories: Extra Small, Small, Medium, Large and Extra Large.





Press one of the buttons to select the desired patient size.

In one point mode, the patient size affects the values of kV.

In two point mode, the patient size affects the values of mAs. Depending on the configuration, the patient size buttons can be disabled for two point mode.

The default values for adjusting kV and mAs are listed in the following tables.

Table 25: kV variation over patient size

	Patient size	kV
	Extra Small	normal kV * 0.9
	Small	normal kV * 0.95
	Medium	normal kV
	Large	normal kV * 1.05







	Patient size	kV
	Extra Large	normal kV * 1.1

Table 26: mAs variation over patient size

	Patient size	mAs
	Extra Small	normal mAs * 0.25
	Small	normal mAs * 0.5
	Medium	normal mAs
	Large	normal mAs * 2
	Extra Large	normal mAs * 4

AEC dose failure

In AEC mode the exposure is interrupted automatically, when there is not enough dose detected within a certain time (e.g. when the AEC chamber is defect or covered with lead foil) or when there is too much dose detected within a certain time (e.g. when no patient is in front of the AEC).

X-ray tube load

Table 27: X-ray tube load

80%	As a way to increase the tube life cycle, the power percentage of the tube is reduced to a 80% by default.
100%	If a specific technique requires 100% of the X-ray tube power, touch the 100% button.

Depending on the status of the heat units, the system may limit the X-ray tube load, even when the X-ray tube load is set to 100%.

DAP Value

The DAP value shows the radiation value of the last exposure. The radiation measure is read as DAP value (Dose Area Product) in $\text{cGy}\cdot\text{cm}^2$ (for example: DAP 12.22). This measurement unit is configurable.

A new exposure resets the DAP value.

Heat Units

The status of the heat units is displayed below the X-ray icon.

During exposures, the heat units are calculated and totalled. The heat units display shows the percentage of the thermal capacity of the X-ray tube that is used. For example, a display of "HU 0" (0%) would indicate that all the heat units capacity of the X-ray tube remains. A display of "HU 100" (100%) would indicate that maximum heat capacity of the X-ray tube is reached and no exposures can be made until the tube has cooled down.

X-ray modality screen

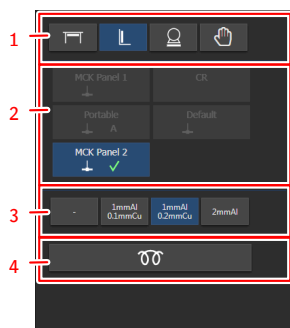

1. Modality position.
2. DR detector switch

All configured detectors are displayed. Only the detectors that can be used with the selected modality position, can be selected.

3. X-ray filter
4. Automated workflow for warming-up of the X-ray tube

Figure 42: X-ray modality screen on the software console

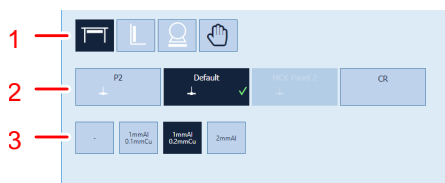

1. Modality position.
2. DR detector switch

All configured detectors are displayed. Only the detectors that can be used with the selected modality position, can be selected.

3. X-ray filter

Figure 43: X-ray modality screen on the tube head display

The X-ray modality screen is also available on the tube head display.

System messages screen

System messages are displayed at the bottom of the software console.

The color of the message indicates the importance:

Blue	Information
Yellow	Warning
Orange	Error

Messages that require feedback from the user contain a button that can be pressed.

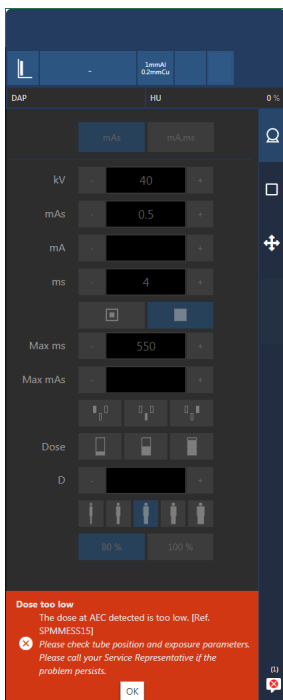

Figure 44: Error message requiring user feedback

More than one message can be active. The number of active messages and the type of messages is indicated on the navigation button.



Figure 45: Icon indicating that messages are waiting

The system messages screen lists all messages since the last startup of the software.

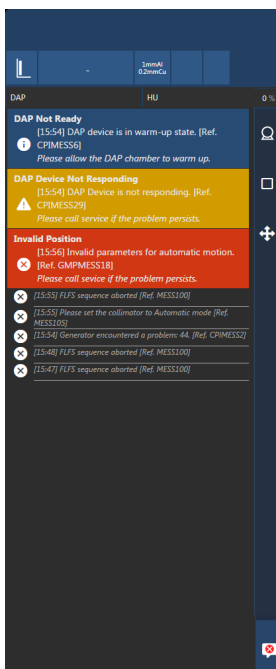

Figure 46: Messages history

Related information

[X-ray generator messages and warning signals \(Spellman\)](#) on page 176

Radiographic Table and X-Ray Tube Stand

The radiographic table with integrated X-ray tube stand allows X-ray examinations from head to foot of lying or sitting patients.

The tube stand has two variants, depending on the side where the tube stand rail is protruding:

- Left hand version
- Right hand version

The table has two variants:

- table with fixed height
- elevating table with adjustable height

The table has a floating table top.

The table has blue LED in the table foot that is lit when the radiographic table is selected as active workstation.

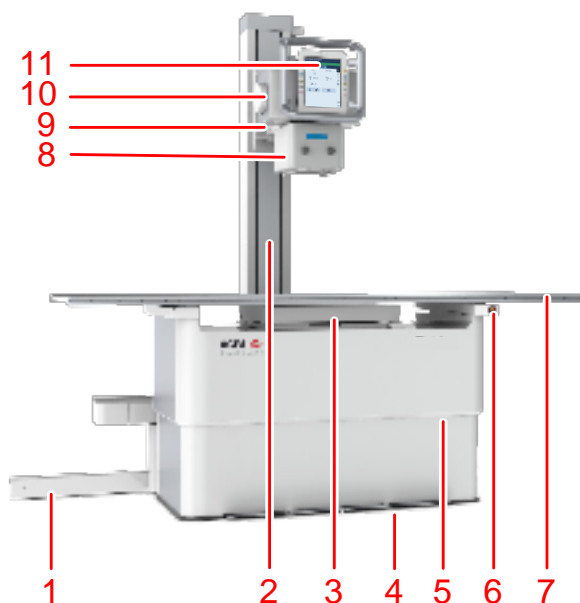

1. Rail system
2. X-ray tube stand with SID ruler
3. Bucky
4. Tabletop movement pedals,
Blue LED indicator light for active workstation
5. Table covers with standard exposure height marker
6. Emergency stop button
7. Tabletop
8. Collimator
9. X-ray tube arm
10. X-ray tube
11. Control panel of the X-ray tube stand

Figure 47: Radiographic table with integrated X-ray tube stand, example of left hand version



1. Movement control buttons
2. Tube head display
3. Handle with integrated release button for omni direction movement.

Figure 48: Control panel of the X-ray tube stand

Depending on the configuration, an extra control button for omni direction movement is available on the lower side of the handle.

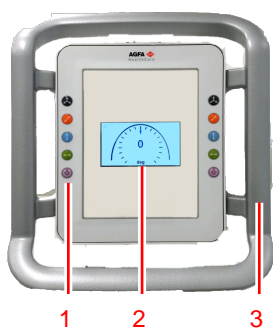

1. Movement control buttons
2. X-ray tube angle display
3. Handle

Figure 49: Control panel of the X-ray tube stand

- [Positioning the X-Ray Tube Stand](#) on page 117
- [Positioning the radiographic table](#) on page 121
- [Positioning the Bucky](#) on page 124
- [Radiographic Table Accessories](#) on page 125
- [Manual Collimator](#) on page 132
- [Automatic Collimator](#) on page 134
- [Effect of SID on patient dose](#) on page 138









Positioning the X-Ray Tube Stand

The operation controls of the X-ray tube stand are located at the control panel. The X-ray tube stand must be positioned by the operator manually.

To release the brake for the selected movement direction or rotation, press and hold the button and move the X-ray tube stand.

To stop the movement and activate the brake, release the button.

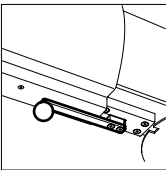
Table 28: Movement controls

	<p>Omni direction movement (longitudinal, vertical and alpha rotation)</p>
	<p>Transversal axis movement (back & front). A marker on the X-ray tube arm indicates the center position.</p> 
	<p>Vertical axis movement (up & down) A ruler on the X-ray tube stand indicates the SID when the radiographic table is positioned on the standard exposure height. The lower edge of the X-ray tube arm mounting is used for reference.</p> 
	<p>Longitudinal axis movement (right & left)</p>
	<p>Alpha axis rotation (Angle of the X-ray tube)</p>
	<p>Beta axis rotation (swivel of the X-ray tube arm around the tube stand axis)</p> 

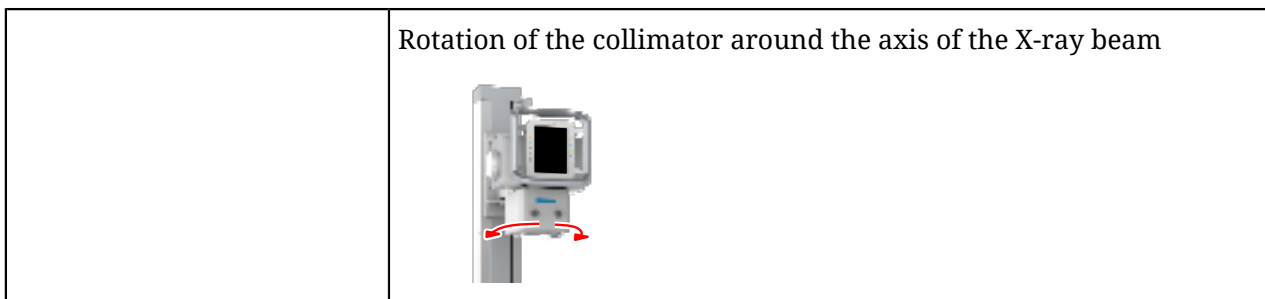

The standard position of the X-ray tube arm is indicated by markers. When the tube arm is in standard position it is centered in transversal direction on the bucky.



Note To avoid shock and damage, move the column with normal speed and slow down when reaching the mechanical end stops.



Caution: If a grinding noise is heard during vertical movement of the X-ray tube arm or radiographic wall stand, the steel cables inside the tube stand or wall stand could be broken. Do not operate the unit any further and try to avoid hard vibration or knocks of any kind. Please contact service.



Caution: Rotation may be limited by cables. Avoid strain on the cables during rotation.

- [Stop positions](#) on page 119
- [Collision indicator](#) on page 120

Related information

[Movement ranges](#) on page 209

[Manual Collimator Technical Data](#) on page 216

[Automatic collimator technical data](#) on page 217

[Positioning the Bucky](#) on page 124

[Centering and collimating](#) on page 155

Stop positions

The system includes stop positions.

- On the longitudinal axis movement, to position the X-ray tube in regularly used exposure distances to the radiographic wall stand, e.g. 150 cm and 180 cm.
- On the vertical axis movement, to position the X-ray tube stand in regularly used exposure distances to the radiographic table, e.g. 115 cm.

The preferred positions of the stops are defined during installation.

The vertical stop on the tube stand is always active. Vertical stops on the tube stand are not available on the fixed height radiographic table types TS-Fix-L-001 and TS-Fix-R-001.

The two transversal stops are active when the X-ray tube is rotated towards the wall stand ($90^{\circ} \pm 10^{\circ}$).

To enter a stop position, move the X-ray tube stand or the X-ray tube arm in longitudinal or vertical direction. The movement is stopped when the stop position is reached. Moving too fast may cause the X-ray tube stand to skip the stop position.

To leave a stop position, release and press again the according movement control button.

Collision indicator

Systems with motorized movement have a collision indicator. The collision indicator avoids collision of the X-ray tube head with the table.

The collision indicator will give a signal in following situations:

- The X-ray tube head is moved manually close than 30 cm to the table top when performing an examination using the table.
- The X-ray tube head is moved manually closer than 10 cm to the table top when performing an examination using the wall stand and the X-ray tube head is rotated toward the wall stand.

The brake is activated and a single beep indicates the collision warning.

To further adjust the position, release the brake button and press it again.

Related information

[X-ray tube stand tracks wall stand height](#) on page 92

Positioning the radiographic table

There are two versions of the radiographic table:

- Fixed height radiographic table with a height of 70 cm
- Elevating radiographic table with adjustable height from 55 cm to 90 cm

The movements of the radiographic table are controlled by foot pedals mounted at front side of the table.



Warning: Maintain visual contact with the patient while moving the equipment close to the patient in order to detect hazardous situations (e.g. collisions) early and to avoid them.



Warning: Make sure that no persons or objects are within the movement area of the system where they can collide with moving parts of the system.

- [Positioning the floating tabletop](#) on page 122
- [Adjusting height](#) on page 123

Related information

[Collision protection](#) on page 128

[Collision indicator](#) on page 120

[Emergency stop button](#) on page 29

Positioning the floating tabletop

To release the brake for moving the floating tabletop, double click and hold the foot pedal. The tabletop can be moved in longitudinal and transversal direction manually.

To stop movement and activate the brake, release the foot pedal.

Table 29: Movement controls

	Foot pedal to release the brake for the floating table top.
---	---



Note When the equipment is switched off, the tabletop can be moved freely. Pay extra attention when a patient needs to get off from the table.

Have the patient get on or off the table in the center of the table. If the table top is extended to the maximum length at the head or foot end, the patient must not sit on the end of the table top, since the weight load can lead to table deformations and damage to the product.

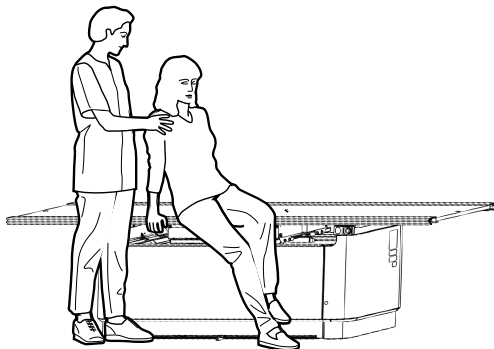

Figure 50: Getting on and off the radiographic table



In case of very heavy patients the table top has to be positioned in center before the patient getting on. The table top must remain in center also during examination.

The radiographic table is designed for a maximum patient weight of 400 kg.

Adjusting height

To adjust the height, double click and hold the foot pedal.

Table 30: Movement controls

	Foot pedal to lower table height (minimum 55 cm).
	Foot pedal to raise table height (maximum 90 cm).

When minimum or maximum position of the table is reached, the movement is stopped automatically.

If the standard exposure height stop position (optional) is enabled, the movement is stopped automatically when the standard exposure height (70 cm) is reached. To continue the movement, release the foot pedal and double click it again.

Markers on both sides of the table covers indicate the standard exposure height position.



Figure 51: Standard exposure height

Positioning the Bucky

The bucky center position is automatically aligned to the position of the X-ray tube stand. The mechanical coupling between the bucky and the X-ray tube stand is active within the travel range of the bucky.

The bucky can be positioned independently from the X-ray tube stand, e.g. for oblique X-ray exposures.

To position the bucky independently from the X-ray tube stand:

1. Move the X-ray tube stand on the longitudinal axis outside the travel range of the bucky.
The mechanical coupling is released.
2. Press and hold the bucky lock switch.

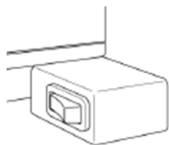

Figure 52: Bucky lock switch

The lock for the bucky movement is released.

3. Move the bucky in longitudinal direction.
4. Release the bucky lock switch.
The position is locked.

Radiographic Table Accessories



Warning: Using wrong accessories that cannot be properly attached to the system can lead to hazardous situations and injury. Use only original accessories provided by the manufacturer.

- [Mounting the patient hand grips](#) on page 126
- [Mounting the tabletop hand grips](#) on page 127
- [Collision protection](#) on page 128
- [Mattress](#) on page 129
- [Lateral cassette holder](#) on page 130
- [Compression belt](#) on page 131

Mounting the patient hand grips

The pair of patient hand grips are used to stabilize the patient and give a feeling of security. Using the hand grips will avoid the patient grasping the table edges which could cause a risk to pinch fingers.

To mount a hand grip:

1. Slide the hand grip in the rails of the tabletop.
2. Tighten the hand screw to lock the hand grip in position.

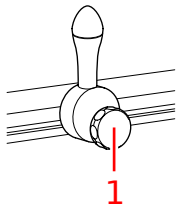

1. Hand screw

Figure 53: Hand grip



Note The hand grips are not intended to support the weight of the patient.

Mounting the tabletop hand grips

The pair of tabletop hand grips are used by the operator for moving the floating tabletop. Using the hand grips will avoid the operator grasping the table edges which could cause a risk to pinch fingers.

To mount a hand grip:

1. Slide the hand grip in the rails of the tabletop.
2. Mount the stop blocks at the end of the rails to prevent the hand grip from sliding out of the rail.

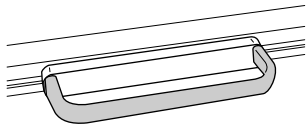

Figure 54: Hand grip

Collision protection

Collision protection is only available on the elevating radiographic table.

The collision protection accessories are mounted on the frame of the radiographic table. They protect the tabletop from damage when colliding with objects below.

When the collision protection stops downward movement of the radiographic table, raise the table height and remove the object before lowering the table again.



Note The collision protection is influenced by the patient weight. Take special care when moving the radiographic table with a patient lying on.

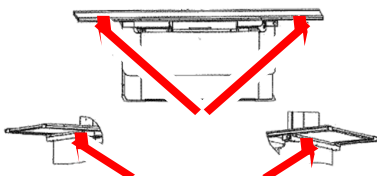

Figure 55: Location of the collision protection accessories

Mattress

The mattress fits the tabletop (220 cm x 80 cm) and is X-ray translucent.

Lateral cassette holder

The lateral cassette holder supports a cassette or detector in lateral position and is attached to the tabletop.

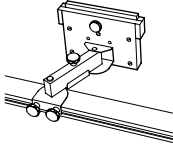

Figure 56: Lateral cassette holder

Compression belt

The compression belt provides additional fixation for the patient on the table. It can be adjusted to patient thickness.

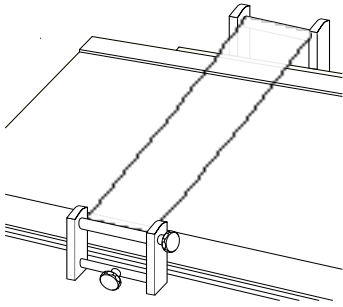
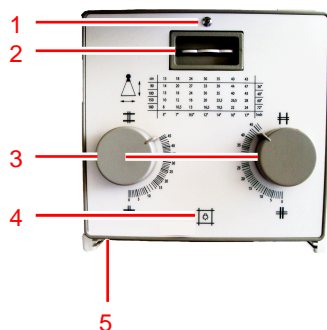

Figure 57: Compression belt

Manual Collimator

The Collimator can rotate $\pm 90^\circ$ on its vertical axis while the X-ray tube remains in the same position. This movement is performed by manually turning the collimator and has detents every 90° .



1. Filter indicator.
2. Filter selection wheel.
3. Knobs to adjust the internal blades.

The table on the front panel shows the number to set with the knobs for each combination of SID and image size.

4. Button to switch on the light field indicating the collimated area and the laser light indicating the center position.

After pressing the button, they remain lit for a few seconds before automatically switching off.

5. Measurement tape to measure the distance between the focal spot of X-ray tube and the tabletop.

The measurement tape is at the rear side of the collimator.

Figure 58: Ralco 221 collimator controls

Another button to switch on the light field is available on the radiographic wall stand.

- [Dose Area Product Meter \(DAP\)](#) on page 132

Related information

[Radiographic wall stand](#) on page 138

Dose Area Product Meter (DAP)

An optional radiation meter can be installed under the manual collimator and reads the radiation as Dose Area Product in [$\text{cGy} \times \text{cm}^2$].

The measured radiation value is transferred to the X-ray generator console and the Software Console automatically and displayed after each exposure. No value is displayed if the measured radiation value is below the minimum readout value of the DAP meter.

The DAP meter can be removed from the rail system to be cleaned or serviced. To remove the radiation meter:

1. Disconnect the cable of the radiation meter.

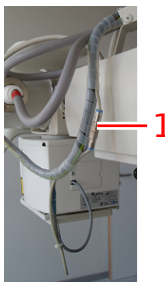

1. cable connecting the radiation meter to the generator
2. Unscrew the screw on the left hand side of the rail system.
3. Pull out the radiation meter.



The DAP meter is calibrated during production to be used up to 2000 m altitude. Using the DAP meter on higher altitudes requires the application of a correction factor.

Related information

[Dose Area Product Meter \(VacuTec DAP\) Technical Data](#) on page 219

Automatic Collimator

The collimator can limit the collimated area to the size of the cassette or DR Detector inserted in the bucky.

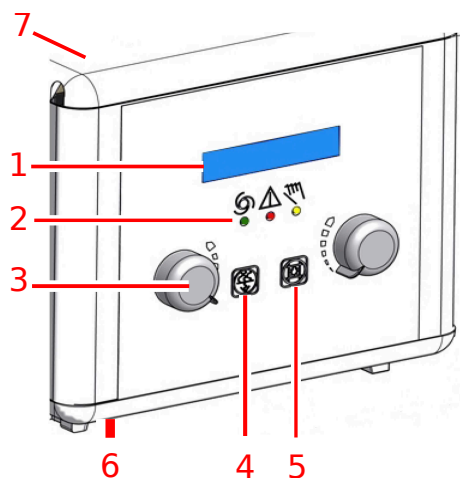

1. Display

- Size of the collimated area
- Active filter

2. Operation mode indicators

- Green: automatic mode
- Red: error mode
- Yellow: manual mode

3. Knobs to adjust the internal blades

4. Button to change the filter

5. Button to switch on or off the light field.

After pressing the button, the lamp remains lit for a few seconds before automatically switching off. The time for the collimation light is configurable by service between 10 and 60 seconds.

6. Measurement tape to measure the distance between the focal spot of X-ray tube and the tabletop

7. Key to switch to manual mode

The key is located on the backside of the collimator.

Figure 59: Ralco 225 ACS collimator controls

Another button to switch on the light field is available on both sides of the radiographic wall stand.

The collimator operates in full automatic mode normally. Other operation modes are manual collimation mode and semi-automatic collimation mode.

- [Semi-automatic collimation mode](#) on page 135
- [Manual collimation mode](#) on page 136
- [Dose Area Product Meter \(DAP\)](#) on page 137

Semi-automatic collimation mode

The semi-automatic collimation mode is activated if any of following conditions applies:

- the tube head unit is rotated out of the center position
- the SID on the radiographic table is not within 90 cm to 130 cm
- the SID on the radiographic wall stand is not within 90 cm to 205 cm
- the tube head unit is not centered to bucky

In semi-automatic collimation mode the registration of the cassette or detector format in the bucky is stopped, but the collimation is still adapted when the SID is changed. The user can adjust the collimation manually.



Figure 60: Indication on the tube head display for semi-automatic collimation mode

Manual collimation mode

The manual collimation mode is activated when the user turns the key at the backside of the collimator. The yellow indicator at front of collimator is lit and an open key lock is displayed in the lower left corner of the collimator display.

Manual mode is used to set the collimation area larger than the size of the cassette or detector, e.g. for detector calibration. The collimation field size is not limited to cassette or detector size nor kept constant with changing SID.



Figure 61: Indication on the tube head display for manual collimation mode

Dose Area Product Meter (DAP)

An integrated DAP meter (Dose Area Product Meter) in the automatic collimator is available as an option.

The DAP meter reads the radiation as Dose Area Product in [$\text{cGy} \times \text{cm}^2$].

The measured radiation value is transferred to the Software Console automatically and displayed after each exposure. No value is displayed if the measured radiation value is below the minimum readout value of the DAP meter.

The DAP meter cannot be removed from the collimator.

The DAP meter is calibrated during production to be used up to 2000 m altitude. Using the DAP meter on higher altitudes requires the application of a correction factor.

Effect of SID on patient dose

Changing the distance of the X-ray tube to the patient affects the dose applied to the patient.

For example doubling the distance reduces the dose by a factor of 4. The new dose can be calculated by a formula:

$$\text{new mAs} = \text{known mAs} \times \left(\frac{\text{new distance}^2}{\text{old distance}^2} \right)$$

Radiographic wall stand

The radiographic wall stand allows vertical X-ray exposures of patients standing or sitting in front of the radiographic wall stand.

The wall stand has two variants:

- wall stand with vertical bucky, supporting vertical movement (up and down)
- wall stand with tilting bucky, supporting vertical movement (up and down) and tilting of the bucky

The bucky has two variants, depending on the orientation for loading a detector or cassette:

- Right hand side loading
- Left hand side loading

The wall stand bucky is height adjustable in a large range.

The wall stand has blue LED in the top that is lit when the radiographic wall stand is selected as active workstation.

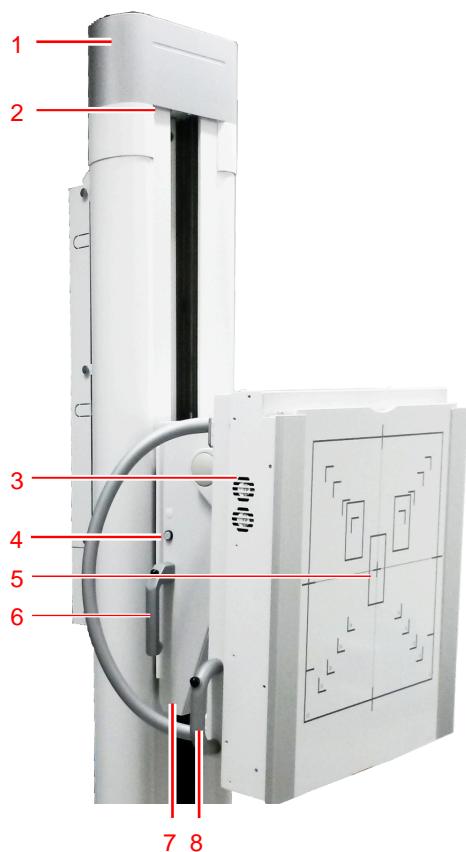

1. Wall Stand column
2. Active workstation indicator
3. Bucky
4. Button to switch on the collimator light
5. Front panel
6. Vertical movement handle (both sides)
7. Tilting extension
8. Tilting handle

Figure 62: Radiographic wall stand, vertical version and vertical tilting version



Caution: The format indications on the front of the bucky unit show the format and position of the cassette or detector. Take into account that the actual area for imaging is smaller than indicated. The image of the exposed object is slightly magnified because there is a distance between the front of the bucky unit and the cassette or detector. The sensitive area of the cassette or detector may be slightly smaller than the indicated area. Check the technical data of the cassette or detector for exact values.



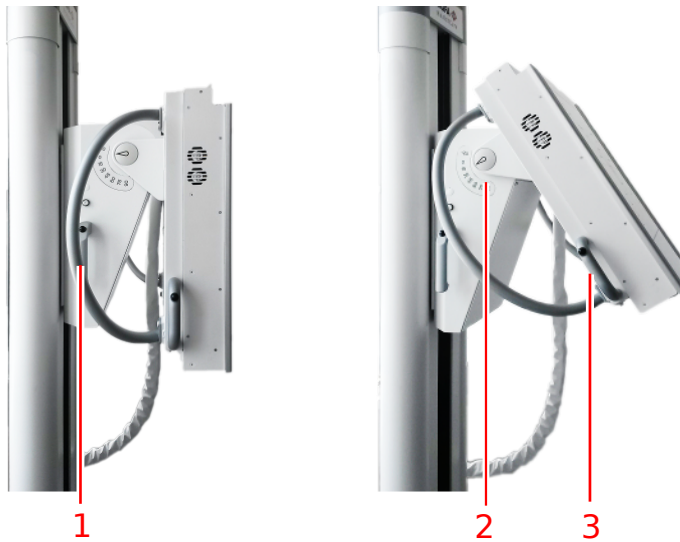

- [Positioning the Radiographic Wall Stand](#) on page 140
- [Radiographic Wall Stand Accessories](#) on page 142

Positioning the Radiographic Wall Stand



1. Vertical movement handle with brake switch
2. Tilting angle scale
3. Tilting handle



Figure 63: Positioning controls

-  **DANGER:** Make sure that no persons or objects are within the movement area of the system where they can collide with moving parts of the system.
-  **Warning:** Maintain visual contact with the patient while moving the equipment close to the patient in order to detect hazardous situations (e.g. collisions) early and to avoid them.
-  **Warning:** Be careful not to squeeze your finger or hand. Keep your hands at the handles while positioning the system.
-  **Warning:** If the tilting bucky is out of vertical position, do not use auto collimation. In this case switch the collimator to manual mode. When using automatic collimation on a tilting bucky, make sure that the bucky is in vertical position.

Vertical movement

To release the brake for vertical movement, press the switch that is integrated at the upper side of the handle located at the left and right side of the radiographic wall stand. The bucky can be moved up and down.

To stop movement and lock the bucky into position, release the switch.

-  **Caution:** The maximum load for the wall stand movement in vertical direction is 20 kg. The bucky unit may slip downwards when applying excessive load.
-  **Note** Do not move the bucky with excessive force to the end stop positions.

Tilting

To tilt the bucky, press and hold the button on the tilting handle and move the bucky. The scale for the angle is visible at the mounting point of the bucky.

To lock the bucky into position, release the button on the tilting handle.



Note The bucky can be tilted to horizontal position. Do not use the bucky as a seat.

Related information

[Centering and collimating](#) on page 155

Radiographic Wall Stand Accessories



Warning: Using wrong accessories that cannot be properly attached to the system can lead to hazardous situations and injury. Use only original accessories provided by the manufacturer.

- [Patient hand grips](#) on page 143
- [Mounting the lateral arm rest](#) on page 144
- [Spacer](#) on page 145
- [Wall stand fixation kit](#) on page 146

Patient hand grips

The patient hand grips for wall stand are mounted fixed at the backside of the bucky. The patient uses these grips for stabilization and support of correct positioning, e.g. for chest exams.

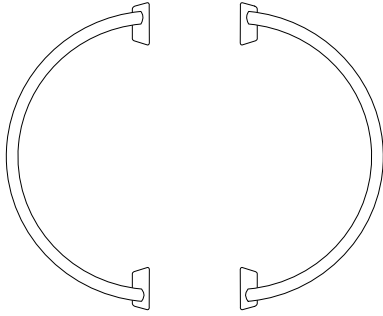

Figure 64: Patient hand grips

Mounting the lateral arm rest



Caution: The lateral arm rest can bear up to 20 kg. It is not intended to hold the whole weight of a patient.

Take care that the lateral arm rest does not collide with the ceiling when moving the bucky upward manually. For automatic movement, a sensor detects if the lateral arm rest is inserted and the movement is coordinated accordingly.

Do not insert the lateral arm rest oriented parallel to the bucky. The lateral arm rest may collide with the wall stand column.

To mount and position the lateral arm rest:

1. Insert the lateral arm rest on the left or on the right side of the bucky frame.
2. Grip the lower part of the lateral arm rest.
3. Pull the lateral arm rest forward
4. Adjust the angle.
5. Move the lateral arm rest back to fix the position.

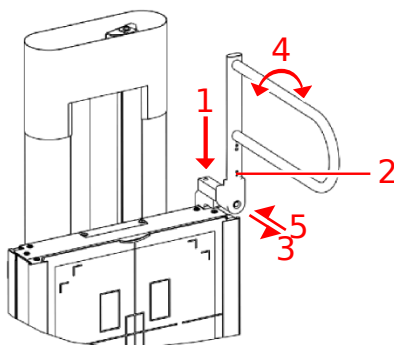

Figure 65: Lateral arm rest

Movement of the X-ray tube head is restricted in the neighbourhood of the lateral arm rest, to avoid collisions. To allow free movement of the tube head, the lateral arm rest must be unmounted from the wall stand. It is not sufficient to turn it 90 degrees out of the way.

Spacer

The spacer allows examination of sitting patients by offering additional space to position legs and feet under the bucky.

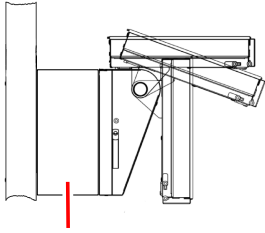

Figure 66: Spacer

Wall stand fixation kit

For additional stability of the radiographic wall stand an additional fixation of the radiographic wall stand is provided. The kit is installed at backside of the radiographic wall stand under the head cover and then fixed to a wall. It has to be installed by service.

Bucky

The bucky is installed in the radiographic table and in the radiographic wall stand.

The bucky clamps the cassette or detector during exposure and centers them relative to the Automatic Exposure Control (AEC) and the grid.

The bucky supports cassettes in standard formats as well as DR Detectors with cassette size format.

The bucky functionalities can be configured according the customer needs.

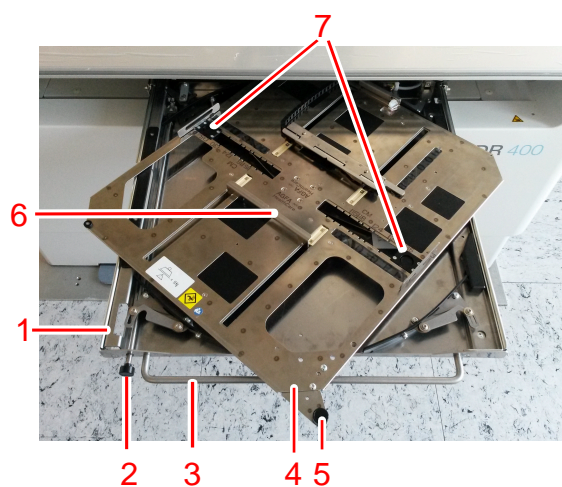

1. Bucky drawer
2. Button to release the brake
3. Bucky drawer handle
4. Carrier for the cassette or detector
5. Knob for rotating the cassette or detector
6. Clamps
7. Side clamps

Figure 67: Bucky



1. Tabletop
2. Removable grid
3. Automatic exposure control (AEC)
4. Carrier for cassette or detector
5. Bucky drawer with rotation mechanism

Figure 68: Bucky front view

- [Bucky configuration](#) on page 148
- [Rotating the bucky](#) on page 149
- [Loading of the bucky in the Radiographic Table](#) on page 150
- [Loading of the bucky in the Radiographic Wall Stand](#) on page 151
- [Unloading of the bucky in the Radiographic Table](#) on page 152
- [Unloading of the bucky in the Radiographic Wall Stand](#) on page 153
- [Automatic Cassette Size Sensing](#) on page 154
- [Centering and collimating](#) on page 155
- [Bucky types](#) on page 157
- [Cassette and detector formats](#) on page 159
- [Standard cassette formats](#) on page 160
- [DR Detector formats and orientation](#) on page 161
- [Anti-scatter grids](#) on page 169
- [Automatic Exposure Control \(AEC\)](#) on page 173

Bucky configuration

Cassette only configuration

The workflow with cassettes requires removing the cassette from the bucky after each exposure. The cassette has to be scanned using a digitizer to get the final image.

The correct orientation of the cassette is applied by the way it is inserted in the bucky and there is no need to use the rotation mechanism.

In this configuration the rotation mechanism can be blocked during installation by the service engineer.

The bucky provides a protection for double exposure by checking if the bucky is re-armed after each exposure.

Fixed DR Detector configuration

The bucky for the fixed DR detector has no clamping or rotation mechanism. The detector is permanently fixed in the bucky and can not be removed. The detector has a square format and requires no rotation.

Radiographic wall stand configuration

The cassette or detector can be positioned centered or aligned with the upper edge of the bucky, to allow chest exams with patient chin resting at the wall stand front panel.

The bucky is available for left and right side loading of the wall stand.

Rotating the bucky

The cassette or detector in the bucky can be rotated without removing it from the clamping.

To change the orientation of the cassette or detector in the bucky:

1. Open the bucky drawer halfway by pulling the front handle.
2. Rotate the bucky carrier with the clamped cassette or detector using the rotation knob.
 - Rotate clockwise to change from portrait to landscape position
 - Rotate counterclockwise to change from landscape to portrait position



Figure 69: Example: rotate clockwise to change from portrait to landscape position

Make sure the rotation is complete before closing the bucky drawer.

3. Close the bucky drawer using the front handle and pushing the button to release the brake. Make sure the bucky drawer is pushed up to the end to close completely.

Loading of the bucky in the Radiographic Table

To load the bucky with a cassette or detector:

1. Open the bucky drawer completely by pulling the front handle.
2. Push the cassette or detector towards the rear slider to open the clamping mechanism wide enough to contain the cassette or detector.
3. Let the cassette or detector slip into the clamping.



Caution: Make sure your fingers are not between the clamping mechanism and the detector. The clamping mechanism may hurt your fingers, therefore take special care.

4. Align the cassette or detector center indication to the center mark on the clamp.



Caution:

When positioning the cassette or detector out of center:

- The alignment to the X-ray tube must be controlled manually.
 - The AEC cells might not be covered or not covered completely, causing wrong exposure dose. Make sure that AEC cells are covered.
5. Close the bucky drawer using the front handle and pushing the button to release the brake. Make sure the bucky drawer is pushed up to the end to close completely.

Related information

[Orientation of DX-D 10C, DX-D 10G in the bucky](#) on page 166

Loading of the bucky in the Radiographic Wall Stand

To load the bucky with a cassette or detector:

1. Open the bucky drawer completely by pulling the front handle.
2. Rotate the drawer to portrait orientation.
3. Adjust the side clamps to the cassette or detector format by pushing the lock button and moving the clamp.



4. Push the cassette or detector towards the lower slider to open the clamping mechanism wide enough to contain the cassette or detector.
5. Let the cassette or detector slip into the clamping.



Caution: Make sure your fingers are not between the clamping mechanism and the detector. The clamping mechanism may hurt your fingers, therefore take special care.

6. Rotate the cassette or detector if needed to get the correct position for next exposure.
7. Align the cassette or detector. The alignment can be centered or out of center.



Caution:

When positioning the cassette or detector out of center:

- The alignment to the X-ray tube must be controlled manually.
- The AEC cells might not be covered or not covered completely, causing wrong exposure dose. Make sure that AEC cells are covered.

8. Close the bucky drawer using the front handle and pushing the button to release the brake. Make sure the bucky drawer is pushed up to the end to close completely.

Unloading of the bucky in the Radiographic Table

To unload the bucky with a cassette or detector:

1. Open the bucky drawer completely by pulling the front handle.
2. Push firmly with both hands the cassette or detector towards the rear clamp to open the clamping mechanism.



Caution: Make sure your fingers are not between the clamping mechanism and the detector. The clamping mechanism may hurt your fingers, therefore take special care.

3. Lift the cassette or detector and remove it from the clamping. The openings in the carrier allow your fingers to grip the detector or cassette.
4. Load the bucky with another cassette or detector.
 - Alternatively, close the bucky drawer using the front handle and pushing the button to release the brake.

Unloading of the bucky in the Radiographic Wall Stand

To unload the bucky with a cassette or detector:

1. Open the bucky drawer completely by pulling the handle.
2. Rotate the carrier back to portrait position.
3. Push firmly with both hands the cassette or detector towards the lower clamp to open the clamping mechanism.

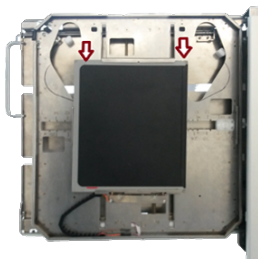

Caution: Make sure your fingers are not between the clamping mechanism and the detector. The clamping mechanism may hurt your fingers, therefore take special care.

4. Remove the cassette or detector from the clamping. The openings in the carrier allow your fingers to grip the detector or cassette.
5. Load the bucky with another cassette or detector.
 - Alternatively, close the bucky drawer using the front handle and pushing the button to release the brake.

Automatic Cassette Size Sensing

The ACSS functionality of the bucky detects the size and orientation of the CR cassette or the DR detector and allows the collimator to limit the collimated area accordingly. The collimation setting received from the NX workstation or the collimation area set by the user is automatically adjusted.

The cassette or detector must be positioned in the center of the bucky. If the cassette or detector is not in the center of the bucky, the collimated area is automatically expanded to expose the whole surface of the cassette or detector. Because automatic collimation is always symmetrical, on one side the exposure will extend beyond the surface of the cassette or detector and the collimation must be corrected manually to apply an asymmetrical collimation area.

The collimator must not be rotated.

The ACSS functionality of the bucky is only available in combination with the automatic collimator. The ACCS functionality is not available when the collimator is in manual mode.

Related information

[Automatic collimator](#) on page 27

Centering and collimating

Depending on the format of the cassette or detector inside the bucky and the body part to expose, collimation and centering of the X-ray field have to be applied before exposure.

Centering

The bucky center position is automatically aligned to the position of the X-ray tube stand.

The bucky provides center marks to check for correct alignment:

- a notch within the hand grip to open/close the bucky drawer.
- a notch in the sliders in the bucky.

To align the X-ray field, adjust the position of the X-ray tube.

The collimator light field contains center lines to check the alignment of the X-ray field to the bucky.

The centering icon on the tube head display indicates the alignment of the X-ray field to the bucky.

Table 31: Centering status on the radiographic table





	<p>X-ray tube is pointing towards table bucky. X-ray tube stand and bucky are mechanically coupled. X-ray tube arm is in center position of transversal axis.</p>
	<p>Any of the above conditions is not true.</p>

Table 32: Centering status on the radiographic wall stand

	<p>X-ray tube is pointing towards wall stand bucky. X-ray tube arm is in mid position of transversal and vertical axis.</p>
	<p>Any of the above conditions is not true.</p>

Collimating

To set the X-ray collimation area, pull out the bucky drawer until the cassette or detector edge is visible. Align the X-ray collimation field to the size of the cassette or detector.

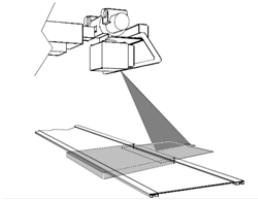

Figure 70: Center line and collimation area

Bucky types

The type of bucky installed in the system defines which functionality is available.

Table 33: Modality positions

Radiographic table	5523/100 5523/110 5523/115 5523/120 5523/125 5523/300
Radiographic wall stand, left loading	5523/200 5523/210 5523/215 5523/220 5523/225 5523/310
Radiographic wall stand, right loading	5523/250 5523/260 5523/265 5523/270 5523/275 5523/320

Table 34: Bucky with tray for multiple cassette or detector formats

Clamping mechanism Rotation mechanism Cassette or detector detection CR double exposure protection AEC	All types
Grid type and status detection Automatic cassette size sensing (ACSS)	5523/120 5523/125 5523/220 5523/225 5523/270 5523/275

Integrated charger for DR 14s DR Detector	5523/115
	5523/125
	5523/215
	5523/225
	5523/265
	5523/275

Table 35: Bucky for fixed DR detector

Radiographic table	5523/300
Radiographic wall stand, left loading	5523/310
Radiographic wall stand, right loading	5523/320
AEC	All types
Grid type and status detection	Depending on configuration

ACSS requires the cassette to be positioned in the center of the bucky. Additionally for the radiographic wall stand, ACSS is supported if a large format cassette or detector (43 cm x 35 cm or 17 inch x 14 inch) is aligned to the top of the bucky in landscape position.

Cassette and detector formats

To adjust the side clamps to the format of the cassette or detector, indications are available in cm (and inch, depending on the bucky type). Corresponding indications are printed on the wall stand cover to align the collimation area.

The 43 cm x 35 cm (17 inch x 14 inch) cassette or detector can be positioned either centered or aligned to the top of the bucky in landscape position.

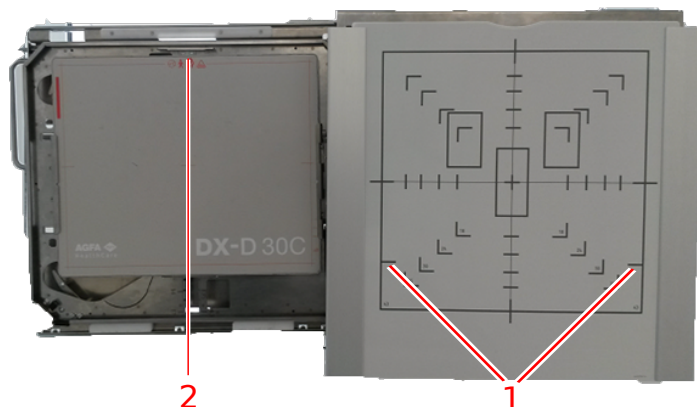

1. Indicators for large format cassette or detector position to the top of the bucky
2. Large format detector positioned to the top of the bucky

Figure 71: Wall stand bucky with large format detector positioned to the top of the bucky

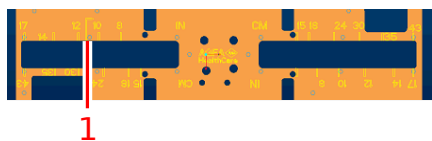

1. Indicators for large format cassette or detector position to the top of the bucky

Figure 72: Indicators on bucky tray

Standard cassette formats

35 cm x 43 cm

35 cm x 35 cm

24 cm x 30 cm

18 cm x 24 cm

15 cm x 30 cm

DR Detector formats and orientation

Refer to the user manual of the DR detector for instructions on the correct orientation of the detector when using it in the bucky.

The following sections contain instructions for specific situations where the instructions in the user manual of the detector do not apply.

- [Orientation of DR 10s in the bucky](#) on page 162
- [Orientation of DR 14s in the bucky](#) on page 164
- [Orientation of DX-D 10C, DX-D 10G in the bucky](#) on page 166
- [Using DX-D 45C, DX-D 45G, XD 10, XD*10 only outside the bucky](#) on page 168

Orientation of DR 10s in the bucky

The clamps of the bucky may trigger the DR 10s power switch.

To avoid switching off the detector when inserting it in the bucky, apply the orientation as described below.

Orientation in the radiographic table

To use the detector in portrait orientation, insert the detector in portrait orientation.

To use the detector in landscape orientation:

1. Insert the detector in portrait orientation.
2. Rotate the detector in the bucky.

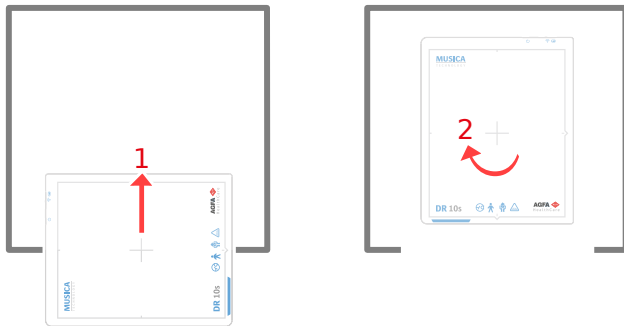

Figure 73: Landscape orientation in the radiographic table

Orientation in the radiographic wall stand left loading

- To use the detector in landscape orientation, insert the detector in landscape orientation.
- To use the detector in portrait orientation:
 1. Insert the detector in landscape orientation.
 2. Rotate the detector in the bucky.

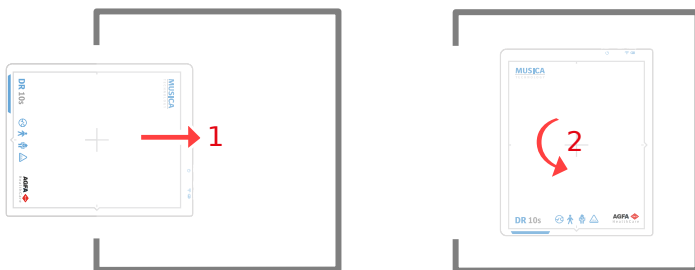

Figure 74: Portrait orientation in the radiographic wall stand left loading

Orientation in the radiographic wall stand right loading

- To use the detector landscape orientation, insert the detector in landscape orientation.
- To use the detector in portrait orientation:
 1. Insert the detector in landscape orientation.
 2. Rotate the detector in the bucky.

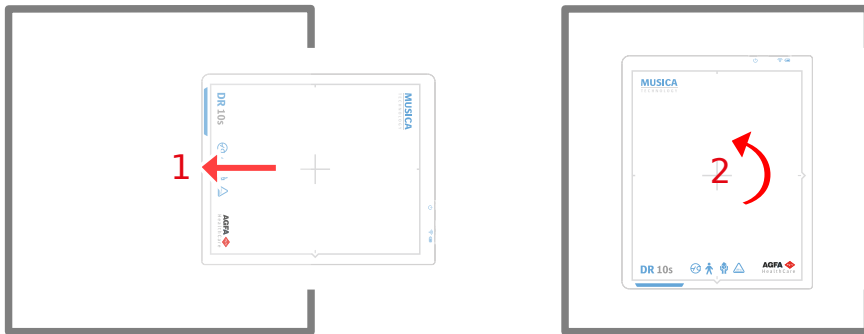

Figure 75: Portrait orientation in the radiographic wall stand right loading

Orientation of DR 14s in the bucky

If the bucky is equipped with an internal DR Detector connector, the battery will be charged while the detector is in the bucky.

Orientation in the radiographic table

To use the detector in portrait orientation, insert the detector in portrait orientation.

To use the detector in landscape orientation:

1. Insert the detector in portrait orientation.
2. Rotate the detector in the bucky.



Figure 76: Landscape orientation in the radiographic table

Orientation in the radiographic wall stand left loading

- To use the detector in landscape orientation, insert the detector in landscape orientation.
- To use the detector in portrait orientation:
 1. Insert the detector in landscape orientation.
 2. Rotate the detector in the bucky.

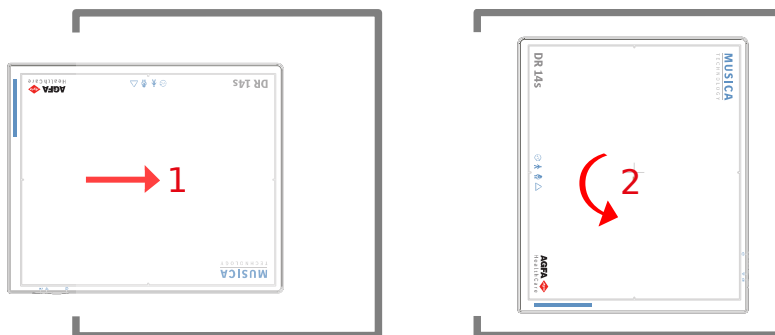

Figure 77: Portrait orientation in the radiographic wall stand left loading

Orientation in the radiographic wall stand right loading

- To use the detector landscape orientation, insert the detector in landscape orientation.
- To use the detector in portrait orientation:
 1. Insert the detector in landscape orientation.
 2. Rotate the detector in the bucky.

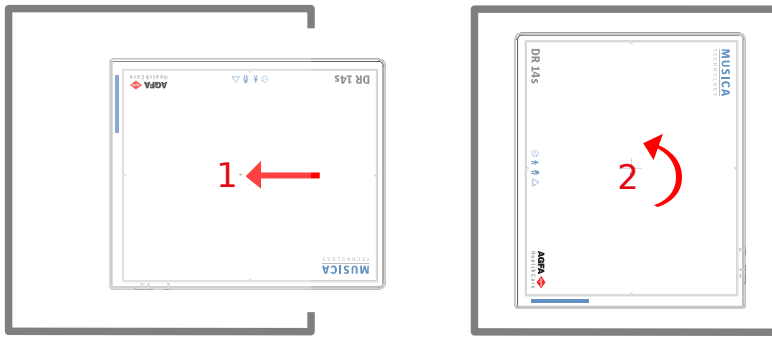

Figure 78: Portrait orientation in the radiographic wall stand right loading

Orientation of DX-D 10C, DX-D 10G in the bucky

To avoid damage to the cable of the detector, there are restrictions on the orientation of the detector when loading the bucky.

Caution: Inserting DX-D 10C, DX-D 10G using other orientations than described will damage the cable when closing the bucky or when rotating the carrier.

Orientation in the radiographic table

To use the detector in landscape orientation, insert the detector in landscape orientation with the cable at lower right hand side.

To use the detector in portrait orientation:

1. Insert the detector in landscape orientation with the cable at lower right hand side.
2. Rotate the detector in the bucky.

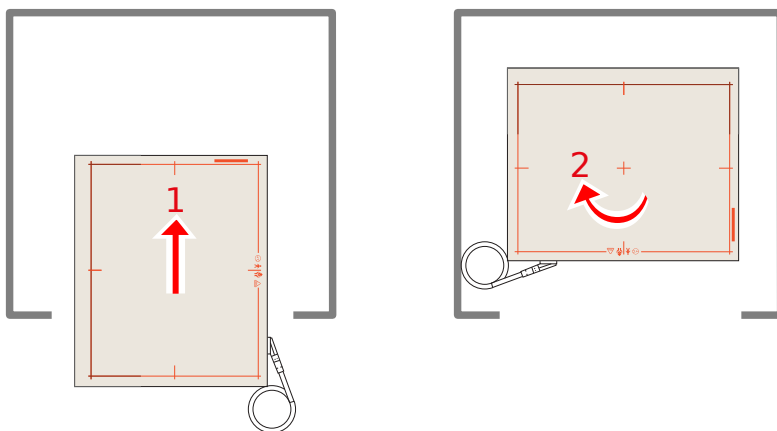

Figure 79: Portrait orientation in the radiographic table

Orientation in the radiographic wall stand left loading

- To use the detector in portrait orientation, insert the detector in portrait mode with the cable at upper left hand side.
- To use the detector in landscape orientation:
 1. Insert the detector in portrait mode with the cable at upper left hand side.
 2. Rotate the detector in the bucky.

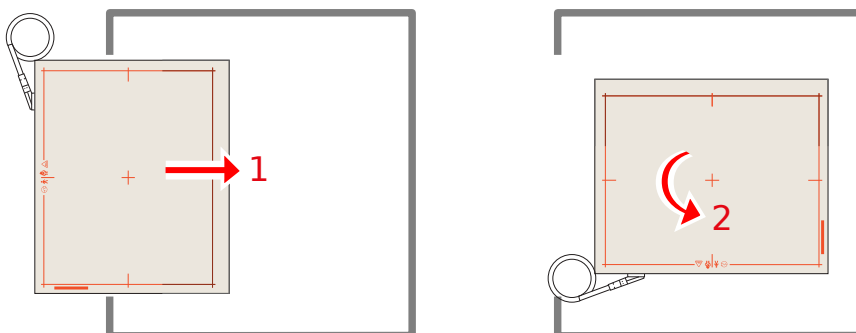

Figure 80: Landscape orientation in the radiographic wall stand left loading

Orientation in the radiographic wall stand right loading

- To use the detector portrait orientation, insert the detector in portrait mode with the cable at bottom right hand side.
- To use the detector in landscape orientation:

1. Insert the detector in portrait mode with the cable at bottom right hand side.
2. Rotate the detector in the bucky.

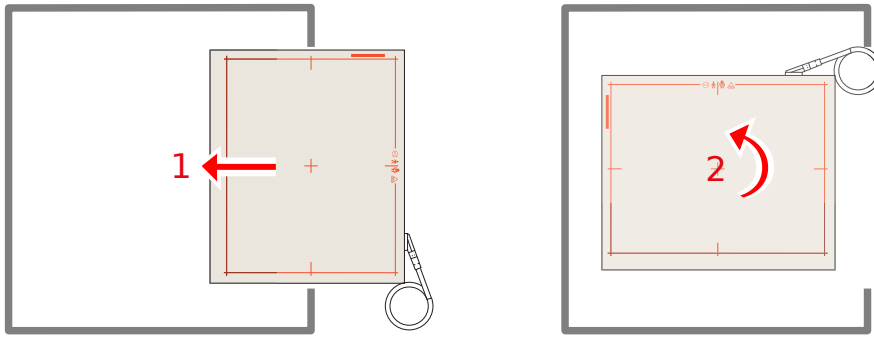

Figure 81: Landscape orientation in the radiographic wall stand right loading

Using DX-D 45C, DX-D 45G, XD 10, XD*10 only outside the bucky

Use the DX-D 45C, DX-D 45G, XD 10 and XD*10 detector only for free exposures. Do not put the detector inside the bucky of the radiographic table or the radiographic wall stand.

Anti-scatter grids

Anti-scatter grids are used to reduce scattered radiation and improve image quality. Grids are available as an option.

For DR detectors focused grids are used. Focused grids require centering of the X-ray source to the detector and a specific distance range between X-ray source and detector. The color of the handle of the grid indicates which distance the grid is used for.

To change the grid in the radiographic table or radiographic wall stand:

1. Pull out the grid using the handle.
2. Store the grid in a safe place to avoid damage.
3. Insert the grid with labels facing up in the appropriate slit of the bucky. Make sure the grid is pushed up to the end.



Caution: Using a focused anti-scatter grid with the X-ray source not centered or on a wrong distance may cause reduced image quality.



Caution: Handle anti-scatter grids with care and store them in a safe place when not in use. Dropping the grid can cause damage and create visible image artifacts or reduce image quality.



Caution: If the anti-scatter grid is not inserted completely, artifacts on the image can be visible, e.g. of the grid edges. Push the grid all the way up to the end.

- [Anti-scatter grids](#) on page 170
- [Anti-scatter grid focal distance color indication](#) on page 171
- [Anti-scatter grid detection](#) on page 171
- [Storage box for DR detector and anti-scatter grids](#) on page 172

Related information

[Bucky Unit Technical Data](#) on page 213

Anti-scatter grids

Anti-scatter grids are used to reduce scattered radiation and improve image quality. Grids are available as an option.





Refer to the Agfa website for specifications on the anti-scatter grids that have been found compatible with the system and the DR Detectors.

<http://www.agfahealthcare.com/global/en/library/overview.jsp?ID=54332498>

Anti-scatter grid focal distance color indication

The handle of the grid is visible when the grid is inserted and its color indicates the focal distance of the grid.

Table 36: Grid focal distance color indication

Focal Distance	Color	
100 cm	red	
150 cm	green	
180 cm	blue	
Parallell grid	gray	

Anti-scatter grid detection

The grid detection functionality of the bucky detects the type and position of the inserted grid.

The grid status is shown on the tube head display and on the software console.

Related information

[Anti-scatter grid status](#) on page 99

Storage box for DR detector and anti-scatter grids

The storage box provides vertical storage space for a DR detector and up to three grids. It can be mounted to the wall or stand on a stable surface.

Caution: insert the DR detector and the anti-scatter grids in the storage box with care to avoid damage. Do not drop the items in the storage box.

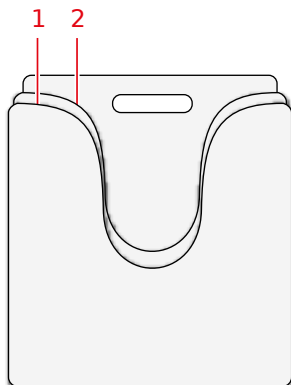

1. Storage space for a DR detector
2. Storage space for up to three grids

Figure 82: Storage box

Automatic Exposure Control (AEC)

The use of an AEC ensures optimal and reproducible image quality independent of the radiation, the object exposed or other factors.

The AEC has three cells (ionization chambers).

The AEC is mounted in the bucky of the radiographic table and the radiographic wall stand between the grid and the detector or cassette. It is fixed and not intended to be removed from the bucky by the customer. If an exposure shall be done without AEC, the free exposure workflow has to be used, where the detector or cassette is placed outside the bucky, or the AEC has to be switched off in the Software Console.

The AEC is calibrated during production with default values. The AEC can be recalibrated during installation, defining three custom cut-off doses for the AEC cells, to suit user preferences or to balance out the three AEC cells.

The default orientation of the AEC cells on the table corresponds to a patient orientation with the head on the left side. The orientation is decided during installation of the system. A label is delivered with the system to indicate the patient orientation on the table.

The shortest irradiation time when using AEC is 2 ms.



Note The AEC cell is located in the bucky above the cassette or detector and may be slightly visible on the image. This applies most to flat field exposures and less to diagnostic images.

Related information

[Automatic Exposure Control \(AEC\) Technical Data](#) on page 215

[Additional Labeling of the radiographic table](#) on page 47

X-Ray Generator Mini Console

The X-ray generator mini console is limited in functionality to power on and power off the generator and to connect the DR Generator Sync with the exposure hand switch to trigger the exposure.

The X-ray exposure parameters are controlled on the **Software Console**.

- [Starting and stopping the generator](#) on page 174
- [X-ray tube start-up modes](#) on page 175
- [X-ray generator messages and warning signals \(Spellman\)](#) on page 176
- [Exposure parameters](#) on page 177
- [Exposure termination](#) on page 180



Related information

[System Documentation](#) on page 202

[Software Console and Tube Head Display](#) on page 85

Starting and stopping the generator

The generator is switched on and off by the power buttons on the X-ray generator mini console.

	Press the Power ON button on the X-ray generator mini console to switch on the generator.
	Press the Power OFF button on the X-ray generator mini console to switch off the generator.

Following warning is printed on the X-ray generator mini console in English:



Warning: This x-ray unit may be dangerous to patient and operator unless safe exposure factors, operating instructions and maintenance schedules are observed.



This label is on the X-ray generator mini console. If the system has just been stopped, wait at least 10 seconds before starting it again, to allow all components to properly shut down.

Related information

[X-ray generator mini console](#) on page 24

[Exposure button](#) on page 24

X-ray tube start-up modes

The system can make exposures using two start-up modes, when pressing the exposure button in preparation stage:

- Low speed start-up that boosts the tube anode to ca. 3000 rpm.
- High speed start-up that boosts the tube anode to ca. 9000 rpm.

No more than four high-speed start-ups are allowed per minute. An error is indicated if the number is exceeded.

High speed start-up is available during no more than 30 seconds. After that period the rotation speed will be reduced to low speed.

After the exposure and when the exposure button is released, the tube anode is braked automatically.

When the X-ray tube anode is rotating with high speed the generator must not be turned off. Please wait until the system is on low speed before switching the generator off. The bearings of the X-ray tube can be damaged if the generator is switched off before the anode is braked.

X-ray generator messages and warning signals (Spellman)

Acoustic signals

The generator indicates particular states with acoustic signals:

- Exposure is terminated: 500 ms tone
- Errors: rapid series of tones

Visual signals

The generator indicates particular states with visual signals:

- Preparation: flashing of prepare ready indicator (green LED)
- X-ray tube is prepared: prepare ready indicator is continuously lit (green LED)
- Exposure: radiation indicator is continuously lit (red LED)

Related information

[System messages screen](#) on page 113

[X-ray generator mini console](#) on page 24

[Exposure button](#) on page 24

Exposure parameters

Tube Voltage

The tube voltage can be selected in steps of 1 kV in the range of 40 to 150 kV.

mAs Product

Step	mAs	Step	mAs	Step	mAs	Step	mAs
0	0.5	10	5.0	20	50	30	500
1	0.63	11	6.3	21	63	31	600
2	0.8	12	8.0	22	80		
3	1.0	13	10	23	100		
4	1.3	14	13	24	125		
5	1.6	15	16	25	160		
6	2.0	16	20	26	200		
7	2.5	17	25	27	250		
8	3.2	18	32	28	320		
9	4.0	19	40	29	400		

Tube current [mA]

Step	mA	Step	mA
0	10	10	100
1	13	11	125
2	16	12	160
3	20	13	200
4	25	14	250
5	32	15	320
6	40	16	400
7	50	17	500
8	63	18	650 (only for generator with 50 kW power or higher)
9	80	19	800 (only for generator with 65 kW power or higher)

Exposure time [ms]

Step	ms	Step	ms	Step	ms	Step	ms
0	1	10	13	20	130	30	1250
1	2	11	16	21	160	31	1600
2	3	12	20	22	200	32	2000
3	4	13	25	23	250	33	2500
4	5	14	32	24	320	34	3200
5	6	15	40	25	400	35	4000
6	7	16	50	26	500	36	5000
7	8	17	63	27	630	37	6300
8	10	18	80	28	800		
9	11	19	100	29	1000		



Note Not all exposure parameters may be available, depending on the configuration of X-ray generator, X-ray tube and DR Detector.

Maximum tube current [mA] at 100 kVp and 0.1 s

	HFe 401 (40 kW)	HFe 501 (50 kW)	HFe 601 (65 kW)	HFe 801 (80 kW)
E7884X	LSS: 400 mA	LSS: 500 mA	-	-
E7252X	LSS: 400 mA HSS: 400 mA	LSS: 450 mA HSS: 500 mA	HSS: 650 mA	-
E7254FX	LSS: 400 mA HSS: 400 mA	LSS: 500 mA HSS: 500 mA	HSS: 650 mA	HSS: 800 mA
E7869XX	-	-	HSS: 650 mA	HSS: 800 mA

- LSS: Low Speed Start option
- HSS: High Speed Start option

All Values are valid for 3-phase generator power line and large focal spot. Values for other exposure conditions can be determined using the technical data of the generator and the data sheets of the X-ray tubes.

In regular use these maximum exposure settings will not create doses that can cause deterministic effects. Effective patient doses for typical exposures are listed in Test Report for IEC 60601-1-3.

Switching between small focus and large focus may have a delay of a few seconds. The focus is controlled by a relais and it requires the filament to cool down before switching.

The settings of kV and mAs or of mA and ms are defined by an algorithm. The highest mA setting is used for which the kV can be reached by the system and the exposure time is not lower than 4 ms. When the kV setting is changed, the value of mA and ms are adjusted automatically to keep the mAs value constant, within the boundaries of generator or X-ray tube limitations.



Note The accuracy for exposure parameter settings complies to EN IEC 60601-2-54 with absolute maximum of 10% for kV and an absolute maximum of 20% for mA.

- [Radiographic Parameter Limits](#) on page 179

Related information

[System Documentation](#) on page 202

Radiographic Parameter Limits

Switching between small focus and large focus may have a delay of a few seconds to enable the filament to warm up before switching.

The settings of kV and mAs or of mA and ms are defined by an algorithm. The highest mA setting is used for which the kV can be reached by the system and the exposure time is not lower than 1 ms or the mAs value is not lower than 0.5 mAs. When the kV setting is changed, the value of mA and ms are adjusted automatically to keep the mAs value constant, within the boundaries of generator or X-ray tube limitations.

If the radiographic parameters limits are reached, a value of a radiographic parameter cannot be increased or decreased, or another value can be automatically adjusted:

- **Radiographic Parameters Limit.** A maximum or minimum radiographic parameter limit is reached. The value cannot be increased or decreased.
- **Generator Power Limit.** The generator power limit (kV x mA) is reached. The value of the selected parameter cannot be increased. When increasing the value of the other parameter, the value of the first parameter will automatically be decreased to keep the mAs value constant.
- **Space Charge.** The space charge limit in the selected X-ray tube is reached by changing the kV or mA values. An information message is displayed.
- **Instantaneous Power.** The instantaneous power limit of the X-ray tube (ratings limit or the X-ray tube is momentarily overheated) is reached by selecting some technique. An information message is displayed.

Exposure termination

In normal operation the exposure is terminated by the generator when:

- mAs product is reached
- Exposure time is reached
- AEC switches off

If the exposure switch is released the exposure is terminated instantaneously and an error is indicated.

In case of failure the exposure is instantaneously terminated when:

- AEC faulty
- Initial dose too high or too low with AEC (if function is activated)
- Maximum exposure time of 3.2 sec reached in 1-point technique with AEC
- mAs product of 600 mAs is reached
- Maximum permissible exposure time of 6.3 sec is reached (safety switch off)
- Door contact is opened

Problem solving

- [Restoring connection between generator and NX after generator failure](#) on page 181
- [Automatic collimation always too wide or too narrow](#) on page 182
- [Empty Bucky Failure, Double Exposure Failure](#) on page 183
- [NX does not connect to the generator due to ID tablet](#) on page 184
- [No table movement](#) on page 185
- [DR Detector is Exceeding the Maximum Working Temperature](#) on page 186
- [DR detector must be recalibrated](#) on page 187
- [System does not start completely if collimator is in manual mode](#) on page 188
- [Tube head display shows screen to check network connection](#) on page 189
- [Radiographic Parameter Limits](#) on page 179

Restoring connection between generator and NX after generator failure

Details	<p>An error on the generator occurred. NX lost connection to the generator.</p> <p>An error message that no connection with the generator can be established is displayed on the Software Console.</p>
Cause	<p>After a shutdown of the generator, the communication between the X-ray generator and the NX workstation is broken.</p>
Brief Solution	<p>To set up the communication between the X-ray generator and the NX workstation:</p> <ol style="list-style-type: none"> 1. Switch off the X-ray generator at X-ray generator console. 2. After some seconds, switch the X-ray generator back on. 3. Select an empty thumbnail in the Image Overview pane of the Examination window. 4. The error message disappears. This may take some time. <p>If an error is indicated on the X-ray generator by a signal, repeat step 1 to 3.</p> <p>During startup of the NX application and the Software Console, the communication to the generator is set up and the self-test of the generator is triggered.</p>

Automatic collimation always too wide or too narrow

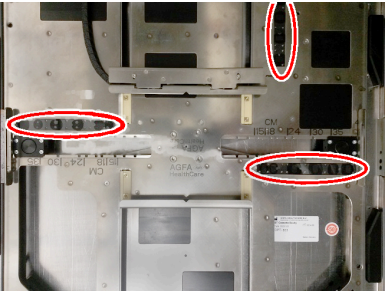
Details	The collimated area is not adapted correctly to the size of the cassette or DR Detector inserted in the bucky.
Cause	The sensors in the bucky that detect the size of the cassette or DR Detector are dirty or have become weak.
Brief Solution	<p>Wipe the sensors in the bucky with a lint-free cloth. If needed, moisten the cloth with a neutral detergent.</p>  <p>Figure 83: Location of the sensors in the bucky</p> <p>If the problem persists, contact your local service organization to exchange the sensors.</p>

Empty Bucky Failure, Double Exposure Failure

Details	<p>The exposure button was pressed but no exposure was performed. No radiation icon is displayed. The preparation icon is displayed.</p> <ul style="list-style-type: none"> • CR: Error message 40 is displayed on the Software Console. • DR: No error message is displayed. An empty image is received in the NX.
Cause	<p>Possible causes:</p> <ul style="list-style-type: none"> • Functionality to avoid double exposure is activated and the cassette has not been removed after the last exposure. This applies to CR only. • No cassette or detector is inserted in the selected bucky.
Brief Solution	<ol style="list-style-type: none"> 1. Enter an unexposed cassette or a detector in the bucky. 2. Confirm the error message in the Software Console. This applies to CR only. 3. On the NX workstation, click Copy Exposure to create a new thumbnail (DR) or click Add Image to add a new exposure. 4. Repeat the steps described in the Basic Workflow.

NX does not connect to the generator due to ID tablet

Details	<p>This occurs on a DR installation in combination with a digitizer using an ID Tablet.</p> <p>The NX application and the Software Console cannot connect to the generator.</p> <p>An error message that no connection with the generator can be established is displayed on the Software Console.</p> <p>Restarting the NX application does not help.</p>
Cause	<p>Conflicting communication sequence during startup of NX between the generator and the ID Tablet.</p>
Brief Solution	<ol style="list-style-type: none"> 1. Switch off the ID Tablet. 2. Stop the NX workstation. 3. Switch on the ID Tablet. 4. Start the NX workstation.

No table movement

Details	The table is not moving up or down when pressing the foot pedals with double click. No error is shown.
Cause	One of the foot pedals was pressed longer than 90 seconds.
Brief Solution	<ol style="list-style-type: none">1. Press the Power OFF button on the X-ray generator mini console to switch off the generator.2. Switch off the electrical room switch.3. Wait for 30 seconds.4. Switch on the electrical room switch.5. Press the Power ON button on the X-ray generator mini console to switch on the system.

DR Detector is Exceeding the Maximum Working Temperature

Details	A message is displayed on NX indicating that the DR Detector is exceeding the maximum working temperature.
Cause	Due to ambient temperature conditions and the number of acquired images, the DR Detector's internal temperature may become too high.
Brief Solution	<ol style="list-style-type: none">1. Power off the DR Detector.2. Leave the DR Detector unpowered for at least one hour.3. Stop the NX workstation.4. Power on the DR Detector.5. Start the NX workstation.

DR detector must be recalibrated

Details	A message is displayed indicating that the DR detector must be recalibrated.
Cause	A DR detector must be recalibrated at regular interval.
Brief Solution	Follow the instructions in the user manual to calibrate the DR detector: <ul style="list-style-type: none">• DR Detector Calibration Key User Manual, document 0134

System does not start completely if collimator is in manual mode

Details	System does not start completely if collimator is in manual mode. An error message is displayed indicating a problem with the collimator during start up.
Cause	The key on collimator was not switched back to automatic mode. The system checks communication with all components during start up. If collimator is in manual mode no communication with the system is available.
Brief Solution	Set the key at the backside of the collimator to automatic. Restart the system on X-ray generator console. A restart of NX is not needed.

Tube head display shows screen to check network connection

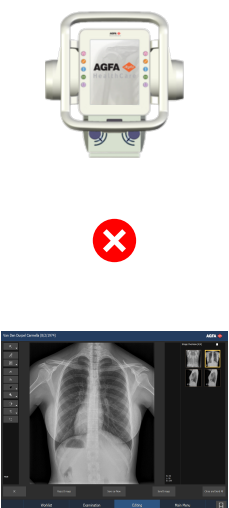
Details	<p>The tube head display shows only the following screen.</p>  <p>The image shows a top-down view of an AGFA tube head display. The screen displays a red 'X' icon, indicating an error. Below the icon is a screenshot of the display's interface, which shows a chest X-ray image and various control buttons.</p>
Cause	The tube head display does not detect a network connection.
Brief Solution	Check on the NX workstation if all network cables are plugged in.

Radiographic Parameter Limits

Switching between small focus and large focus may have a delay of a few seconds to enable the filament to warm up before switching.

The settings of kV and mAs or of mA and ms are defined by an algorithm. The highest mA setting is used for which the kV can be reached by the system and the exposure time is not lower than 1 ms or the mAs value is not lower than 0.5 mAs. When the kV setting is changed, the value of mA and ms are adjusted automatically to keep the mAs value constant, within the boundaries of generator or X-ray tube limitations.

If the radiographic parameters limits are reached, a value of a radiographic parameter cannot be increased or decreased, or another value can be automatically adjusted:

- **Radiographic Parameters Limit.** A maximum or minimum radiographic parameter limit is reached. The value cannot be increased or decreased.
- **Generator Power Limit.** The generator power limit (kV x mA) is reached. The value of the selected parameter cannot be increased. When increasing the value of the other parameter, the value of the first parameter will automatically be decreased to keep the mAs value constant.
- **Space Charge.** The space charge limit in the selected X-ray tube is reached by changing the kV or mA values. An information message is displayed.
- **Instantaneous Power.** The instantaneous power limit of the X-ray tube (ratings limit or the X-ray tube is momentarily overheated) is reached by selecting some technique. An information message is displayed.

Product Information

- [Compatibility](#) on page 191
- [Connectivity](#) on page 192
- [Compliance](#) on page 193
- [Equipment Classification](#) on page 196
- [Patient data security](#) on page 197
- [Product Complaints](#) on page 200
- [Environmental protection](#) on page 201
- [System Documentation](#) on page 202
- [Training](#) on page 203
- [Technical Data](#) on page 204
- [Remarks for HF-emission and immunity](#) on page 228

Compatibility

The system must only be used in combination with other equipment or components if these are expressly recognized by Agfa as compatible. A list of such equipment and components is available from Agfa service on request.

Changes or additions to the equipment must only be carried out by persons authorized to do so by Agfa. Such changes must comply with best engineering practice and all applicable laws and regulations that have the force of law within the jurisdiction of the hospital.

Connectivity

The NX workstation is connected to the X-ray system to exchange X-ray exposure parameters.

The NX workstation requires a 100 Mbit ethernet network to exchange information with a number of other devices.

The NX workstation communicates with other devices in the hospital network using one of the following protocols:

- DICOM
- IHE

The NX workstation can be connected to a RIS system (input scheduling), a PACS system (output image/data management) and to a hardcopy device (output image).



Note The data connections between the components of the system are separate from the hospital network and should not be disconnected or modified.

Related information

[Configuration](#) on page 13

Compliance

The system is compliant with specific directives and standards.

- [General](#) on page 194
- [Safety](#) on page 194
- [Electromagnetic Compatibility](#) on page 195
- [X-Ray Safety](#) on page 195
- [X-Ray Accuracy](#) on page 195
- [Environmental Compliance](#) on page 195
- [Biocompatibility](#) on page 195
- [Usability](#) on page 195

General

- The product has been designed in accordance with Regulation (EU) 2017/745 on medical devices (MDR)
- ISO 13485
- ISO 14971

Safety

- IEC 60601-1
- AAMI ES 60601-1
- CSA C 22.2 No.60601-1

Electromagnetic Compatibility

- IEC 60601-1-2, EN 60601-1-2

For USA

This equipment has been tested and found to comply with the limits for a Class A digital device, pursuant to part 15 of the FCC Rules. These limits are designed to provide reasonable protection against harmful interference when the equipment is operated in a commercial environment. This equipment generates, uses, and can radiate radio frequency energy and, if not installed and used in accordance with the installation manual, may cause harmful interference to radio communications. Operation of this equipment in a residential area is likely to cause harmful interference in which case the user will be required to correct the interference at his own expense. If required, contact your local service organization.

For Canada

This class A digital apparatus meets all requirements of the Canadian Interference-Causing Equipment Regulations.

X-Ray Safety

- IEC 60601-1-3
- IEC 60601-2-54
- IEC 60601-2-28

For USA

The system conforms to DHHS radiation Standards of 21CFR subchapter J as of the date of manufacture.

X-Ray Accuracy

The system fulfills the X-ray radiation accuracy according EN IEC 60601-2-54 with a variation of max. 0.05 (5%).

Environmental Compliance

- European Council Directive 1907/2006 (REACH)
- European Council Directive 2011/65/EU (RoHS 2)
- European Council Directive 2012/19/EU (WEEE)

Biocompatibility

- EN ISO 10993-1

Usability

- IEC/EN 62366
- IEC/EN 60601-1-6

Equipment Classification

Per EN/IEC 60601-1, EN/IEC 60601-2-54, this device is classified as following:

Table 37: Equipment classification

Class I equipment	Equipment in which protection against electric shock does not rely on basic insulation only, but includes a fixed connection to mains power with protective earth conductor.
Type B applied part	A Type B applied part is one that provides a particular degree of protection against electric shock particularly regarding allowable leakage current and reliability of the protective earth protection.
Protection against ingress of solid foreign objects and water	IP10 This device is protected against solid objects with a size (diameter) of 50 mm or larger. This device is not protected against droplets of water.
Cleaning	See section on cleaning and disinfecting.
Disinfection	See section on cleaning and disinfecting.
Flammable anesthetics	This device is not suitable for use in the presence of a flammable anesthetic mixture with air, or in presence of a flammable anesthetic mixture with oxygen or nitrous oxide.
Operation	Continuous operation.

Related information

[Cleaning and Disinfecting](#) on page 54

Patient data security

The user must ensure that the patients' legal requirements are met and that the security of the patient data is guarded.

The user must define who can access patient data in which situations.

The user must have a strategy available on what to do with patient data in case of a disaster.

- [Requirements on the operating environment](#) on page 198
- [Security settings](#) on page 199

Requirements on the operating environment

These operating environment requirements for information security and privacy (ISP), set in compliance with point 17(4) and 18(8) of Annex I of the EU Medical Device Regulation 2017/745, must be implemented and used in connection with the use of the Agfa medical device by the Customer (User). These are minimum requirements and designed to protect against unauthorised access that could hamper the device from functioning as intended.

Although Agfa has defined these ISP Operating Environment Requirements for implementation by the Customer, Agfa makes no warranties, expressed or implied regarding those ISP Operating Environment Requirements.

Agfa disclaims all liability if a security incident would occur despite the implementation of these ISP Operating Environment Requirements by the Customer.

Agfa reserves the right to revise these ISP Operating Environment Requirements and to make changes to them at any time. Possible revisions of the ISP Operating Environment Requirements will only be available in an electronic form, on request, via our website, by using the user documentation request form <http://www.agfahealthcare.com/global/en/library/index.jsp>.

The information presented herein is sensitive and is company confidential. Without written authority from Agfa, further distribution outside the company is not allowed.

- Perimeter firewalls shall be in place and appropriately configured in order to ensure that communications between medical devices and external resources are either denied or restricted to just the communications that are essential for the medical devices to properly function.
- Network Intrusion Detection/Prevention Systems (NIDS/NIPS) shall be in place at the perimeter and appropriately configured, in order to provide early warning of an attack attempt or successful compromise of a medical device as well as to attempt to prevent compromise of medical devices.
- A Network Time Protocol Server shall be configured in the medical devices in order to synchronize the time in the audit logs with the time on the NTP server.
- Medical devices shall be on an isolated network segment that restricts communication of the medical devices to the systems that are required for the device to function.
- Internal firewalls shall be put in place to improve upon network segmentation and to further restrict communications of medical devices to the systems (internal and external) that they need to interact with.
- Medical device configurations shall be backed up in a secure separate device.
- Security controls shall be put in place to ensure that physical access to medical devices is limited only to authorized individuals and that physical theft of the device is prohibited.
- An incident response plan detailing responsibilities and how to react and recover from incidents, shall be in place. Staff involved in the incident response plan shall be trained to respond appropriately and effectively.
- A formal user provisioning and de-provisioning process shall be implemented to enable the appropriate management of access rights to medical devices.
- Users shall be assigned unique accounts to medical devices.
- User access rights to medical devices shall be reviewed for appropriateness and corrected as needed, at regular intervals not exceeding once a year.

Security settings

Refer to the MUSICA Acquisition Workstation User Documentation for more information about security settings in the software.

Product Complaints

Any health care professional (for example a customer or a user) who has any complaints or has experienced any dissatisfaction with the quality, durability, reliability, safety, effectiveness, or performance of this product must notify Agfa.

For a patient/user/third party in the European Union and in countries with identical regulatory regimes (Regulation 2017/745/EU on Medical Devices); if, during the use of this device or as a result of its use, a serious incident has occurred, please report it to the manufacturer and/or its authorised representative and to your national authority.

Contact address:

Agfa Service Support - local support addresses and phone numbers are listed on www.agfa.com

Agfa - Septestraat 27, 2640 Mortsel, Belgium

Agfa - Fax +32 3 444 7094

Environmental protection



Figure 84: WEEE symbol

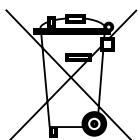

Figure 85: Battery symbol

WEEE end user notice

The directive on Waste Electrical and Electronic Equipment (WEEE) aims to prevent the generation of electric and electronic waste and to promote the reuse, recycling and other forms of recovery. It therefore requires the collection of WEEE, recovery and reuse or recycling.

Due to the implementation into national law, specific requirements can be different within the European Member States. The WEEE symbol on the products, and/or accompanying documents means that used electrical and electronic products should not be treated as, or mixed with general household waste. For more detailed information about take-back and recycling of this product please contact your local service organization and/or dealer. The recycling of materials will help to conserve natural resources.



Caution: By ensuring this product is disposed of correctly, you will help prevent potential negative consequences for the environment and human health, which could otherwise be caused by inappropriate waste handling of this product.

Battery notice

The battery symbol on the products, and/or accompanying documents means that the used batteries should not be treated as, or mixed with general household waste. The battery symbol on batteries or its packaging may be used in combination with a chemical symbol. In cases where a chemical symbol is available it indicates the presence of respective chemical substances. If your equipment or replaced spare parts contain batteries or accumulators please dispose of them separately according to local regulations.

For battery replacements please contact your local sales organization.

System Documentation

The DR 400 user documentation consists of

- DR 400 User Documentation CD (digital media)
- MUSICA Acquisition Workstation (NX) User Documentation USB Flash Drive (digital media)
- User documentation for the supported DR Detectors

The DR 400 User Documentation CD contains:

- DR 400 User Manual (this document)
- DX-D DR Detector Calibration Key User manual, document 0134

Other documentation available on the DR 400 User Documentation CD:

- DAP Datasheet
- X-ray Tube Documentation
- Collimator Datasheet
- AEC Datasheet
- X-ray Generator User Manual
- Test Report for IEC60601-1-3
- Test Report for DIN6868-150

The documentation shall be kept with the system for easy reference.

The most extensive configuration is described within this manual, including the maximum number of options and accessories. Not every function, option or accessory described may have been purchased or licensed on a particular piece of equipment.

Technical documentation is available in the product service documentation which is available from your local support organization.

The most recent version of this document is available on <http://www.agfahealthcare.com/global/en/library/index.jsp>

Training

The user must have received adequate training on the safe and effective use of the system before attempting to work with it. Training requirements may vary from country to country. The user must make sure that training is received in accordance with local laws or regulations that have the force of law. Your local Agfa or dealer representative can provide further information on training.

The user must note the following information in the system documentation:

- Intended Use.
- Intended User.
- Safety Directions.

Technical Data

- [DR 400 Technical Data](#) on page 205
- [Generator Technical Data](#) on page 207
- [Radiographic Table and X-Ray Tube Stand Technical Data](#) on page 208
- [Radiographic Wall Stand Technical Data](#) on page 210
- [X-Ray Tube Technical Data](#) on page 212
- [Bucky Unit Technical Data](#) on page 213
- [Automatic Exposure Control \(AEC\) Technical Data](#) on page 215
- [Manual Collimator Technical Data](#) on page 216
- [Automatic collimator technical data](#) on page 217
- [Dose Area Product Meter \(IBA DAP\) Technical Data](#) on page 218
- [Dose Area Product Meter \(VacuTec DAP\) Technical Data](#) on page 219
- [Fixed DR Detector](#) on page 220
- [Portable DR detector technical data](#) on page 225
- [NX workstation technical data](#) on page 226
- [DR Generator Sync Box technical data](#) on page 227

DR 400 Technical Data

Manufacturer	Agfa NV Septestraat 27 2640 Mortsel, Belgium	
Type	5520/XXX	
Power line 400 V Y-source	400V 3N~ PE (Y) 50/60 Hz	
Power line 400/480 V Delta-source	400/480V 3~PE (delta without N) 50/60Hz The power setting is selected during installation and printed on the type label.	
Maximum current (0.2sec) / Power	400V	480V
40 kW generator	92 A / 62 kVA	79 A / 62 kVA
50 kW generator	113 A / 76 kVA	97 A / 76 kVA
65 kW generator	144 A / 96 kVA	124 A / 96 kVA
80 kW generator	180 A / 120 kVA	154 A / 120 kVA
Stand-by power	max. 3.3 A	
Table movement (full load of 400 kg)	max. 7.0 A	
Energy consumption (according to "COCIR Guidelines for users on saving energy")		
Scenario OFF	2.95 kWh	
Scenario low power	3.71 kWh	
Scenario Ready to scan	5.89 kWh	
Permanent filtration		
E7254FX X-ray tube	2.8 mm Al @75kVp (+ 0.2 mm Al with DAP meter integrated in the collimator)	
E7884X and E7252X X-ray tube	2.9 mm Al @ 75kVp (+ 0.2 mm Al with DAP meter integrated in the collimator)	
E7869X X-ray tube	3.1 mm Al @ 75kVp (+ 0.2 mm Al with DAP meter integrated in the collimator)	

Environmental conditions

Table 38: Environmental conditions for the X-ray system

Environmental Conditions (during storage and transport)	
Temperature (ambient)	between -15° and 50° Celsius
Humidity (non condensing)	between 15 and 90 % relative humidity
Atmospheric pressure	between 70 and 106 kPa
Environmental Conditions (during normal operation)	
Temperature (ambient)	between 10° and 35° Celsius
Humidity (non condensing)	between 30 and 75 % relative humidity
Atmospheric pressure	between 70 and 106 kPa
Maximum altitude	3000 m

For overall system environmental conditions, the environmental conditions of the DR Detector or image plate should be taken into account. Refer to the related User Manual for environmental conditions for the DR Detector or image plate. When using the DR Detector or image plate inside the bucky, take into account that the temperature inside the bucky can be up to 5°C higher than the temperature in the X-ray room.

Related information

[Fixed DR detector environmental conditions](#) on page 223

Generator Technical Data

Manufacturer	Spellman High Voltage Electronics GmbH Josef-Baumann-Strasse 23 D-44805 Bochum, Germany			
Supported Models	EDITOR HFe 401	EDITOR HFe 501	EDITOR HFe 601	EDITOR HFe 801
Max. Power	40 kW	50 kW	65 kW	80 kW
Power Output (at 0.1s)	500mA: 80kVp 400mA: 100kVp 320mA: 125kVp 266mA: 150kVp	625mA: 80kVp 500mA: 100kVp 400mA: 125kVp 330mA: 150kVp	800mA: 80kVp 650mA: 100kVp 520mA: 125kVp 430mA: 150kVp	800mA: 80kVp 800mA: 100kVp 640mA: 125kVp 530mA: 150kVp
kV-Range	40-150 kV	40-150 kV	40-150 kV	40-150 kV
mAs-Range	0.5-600 mAs	0.5-600 mAs	0.5-600 mAs	0.5-600 mAs
mA-Range	10-500 mA	10-650 mA	10-800 mA	10-800 mA
ms-Range	1-6300 ms	1-6300 ms	1-6300 ms	1-6300 ms
Power line 400 V Y-source	400V 3N~ PE (Y) 50/60 Hz			
Power line 400/480 V Delta-source	400/480V 3~PE (delta without N) 50/60Hz The power setting is selected during installation and printed on the type label.			
Dimensions	89 cm x 43 cm x 29 cm (WxDxH)			
Weight	78 kg (400V) 90 kg (400/480V)			
Duty cycle	The Generator duty cycle is continuous, but limits should be set during installation depending on the capacity of the X-ray tube.			

The values for Power Output represent the maximum power output of the X-ray generator. These values do not represent the available exposure parameter settings on the Software Console.

Related information

[Exposure parameters](#) on page 177

Radiographic Table and X-Ray Tube Stand Technical Data

Manufacturer	Agfa NV Septestraat 27 2640 Mortsel, Belgium
Type	
TS-Fix-L-001	5521/100
TS-Fix-R-001	5521/110
TS-Elev-L-001	5521/200
TS-Elev-R-001	5521/210
TS-Fix-L-002	5521/300
TS-Fix-R-002	5521/310
TS-Elev-L-002	5521/400
TS-Elev-R-002	5521/410
Dimensions	
Fixed height radiographic table	140 cm x 77 cm x 70 cm (WxDxH)
Elevating radiographic table	140 cm x 77 cm x 55-90 cm (WxDxH)
Tabletop	220 cm x 81 cm x 4 cm (WxDxH)
Tabletop movement	Longitudinal 110 cm Transversal 24 cm
Maximum SID	110 cm (at 70 cm table height) 130 cm (at 55 cm table height, elevating radiographic table only)
Distance between tabletop and detector	< 60 mm
X-ray tube stand column height	228 cm
X-ray tube stand arm length	93 cm
Minimum room height	245 cm
Tabletop attenuation equivalent mm Aluminum	≤ 0.7 According to DIN EN 60601-1-3 with 100kV and HVL 3.6 mm Al FDA 21 CFR § 1020.30 (n) with 100kV and HVL 3.6 mm Al
Weight	
Fixed height radiographic table	290 kg
Elevating radiographic table	350 kg

X-ray tube stand column	120 kg
X-ray tube stand arm	25 kg
X-ray tube plus collimator (maximum weight)	40 kg
Maximum load on the radiographic table	400 kg

Movement ranges

Transversal axis or y-axis movement (back & front)	± 7 cm
Vertical axis or z-axis movement (up & down)	33.5 cm to 180 cm from the floor The movement range may vary depending on the type of X-ray tube.
Longitudinal axis (x-axis) movement (right & left)	131 cm
Alpha axis rotation (Angle of the X-ray tube)	$\pm 110^\circ$ with mechanical detents at 0° , $\pm 45^\circ$, $\pm 90^\circ$
Beta axis rotation (swivel of the X-ray tube arm around the tube stand axis)	$\pm 90^\circ$ with mechanical detents at 0° , $\pm 45^\circ$, $\pm 90^\circ$
Bucky horizontal movement in the table	50 cm
Rotation of the collimator around the axis of the X-ray beam	$\pm 90^\circ$  Caution: Rotation may be limited by cables. Avoid strain on the cables during rotation.

Radiographic Wall Stand Technical Data

Manufacturer	Agfa NV Septestraat 27 2640 Mortsel, Belgium
Type	
WS-Manual-001	5522/100
WS-Manual-T-001	5522/200
WS-Manual-002	5522/300
WS-Manual-T-002	5522/400
Dimensions	
Height	2245 mm
Width	610 mm (only front panel) 715 mm (with tilting handles) 825 mm (with patient hand grips)
Depth	380 mm (vertical wall stand) 640 mm (tilting wall stand) 730 mm (vertical wall stand with spacer) 990 mm (tilting wall stand with spacer)
Height of detector center	33.5 to 185 cm
Angle of the detector	-20° to +90°
Typical SID range (*)	100 cm to 280 cm (decided during installation)
Distance between front panel and de- tector (*)	48 mm
Front panel attenuation equivalent mm Aluminum	≤ 0.7 According to DIN EN 60601-1-3 with 100kV and HVL 3.6 mm Al FDA 21 CFR § 1020.30 (n) with 100kV and HVL 3.6 mm Al
Weight	

Weight	157 kg (vertical wall stand) 196 kg (tilting wall stand) 166 kg (vertical wall stand with spacer) 205 kg (tilting wall stand with spacer)
Maximum load on the bucky	32 kg
Maximum load on the brakes for the vertical movement	250 N

X-Ray Tube Technical Data

Manufacturer	Canon Electron Tubes & Devices Co., Ltd. 1385 Shimoishigami Otawara-Shi, Tochigi-Ken 324-8550 Japan
E7252X	X-ray Tube 12° 150 kVp dual focal spots 0.6 and 1.2 mm 300 KHU LS 14/41 kW (50Hz) 16/45 kW (60Hz) HS 27/75 kW (180Hz) 7,24x10 ⁶ mAh@150kVp maximum load
E7254FX	X-ray Tube 12° 150 kVp dual focal spots 0.6 and 1.2 mm 400 KHU LS 22/55 kW (50Hz) 23/60 kW (60Hz) HS 40/102 kW (180Hz) 9,66x10 ⁶ mAh@150kVp maximum load
E7869XX	X-ray Tube 12° 150 kVp dual focal spots 0.6 and 1.2 mm 600 KHU LS 21/53 kW (50Hz) 23/58 kW (60Hz) HS 40/100 kW (180Hz) 14,49x10 ⁶ mAh@150kVp maximum load

Bucky Unit Technical Data

Manufacturer	Agfa NV Septestraat 27 2640 Mortsel, Belgium
Type	
BT-Cassette-T-001	5523/100
BT-Cassette-T-GSS-001	5523/110
CASS BUCKY TABLE W/O ACSS INCL DET CHARG	5523/115
BT-Cassette-T-ACSS-001	5523/120
CASS BUCKY TABLE ACSS INCL DET CHARG	5523/125
BT-Cassette-WS-L-001	5523/200
BT-Cassette-WS-GSS-L-001	5523/210
CASS BUCKY WS LL W/O ACSS INCL DET CHARG	5523/215
BT-Cassette-WS-ACSS-L-001	5523/220
CASS BUCKY WS LL ACSS INCL DET CHARG	5523/225
BT-Cassette-WS-R-001	5523/250
BT-Cassette-WS-GSS-R-001	5523/260
CASS BUCKY WS RL W/O ACSS INCL DET CHARG	5523/265
BT-Cassette-WS-ACSS-R-001	5523/270
CASS BUCKY WS RL ACSS INCL DET CHARG	5523/275
BT-Fixed-T-001	5523/300
BT-Fixed-WS-L-001	5523/310
BT-Fixed-WS-R-001	5523/320

Dimensions

Dimensions in radiographic table	65.5 cm x 60.0 cm x 8.0 cm (WxLxH)
Dimensions in radiographic wall stand	62.5 cm x 61.5 cm x 12.5 cm (WxLxH)

Weight (without detector)

Bucky for DR Detector or CR cassette in radiographic table	23.5 kg
Bucky for DR Detector or CR cassette in radiographic wall stand	26.0 kg
DX-D Fixed DR Detector bucky	13 kg
Electrical connection (type 5523/100, 5523/200, 5523/250)	
Operating voltage	24 VDC
Operating current	80 mA
Electrical connection (type 5523/110, 5523/120, 5523/210, 5523/220, 5523/260, 5523/270, 5523/300, 5523/310, 5523/320)	
Operating voltage	24 VDC
Operating current	375 mA
Electrical connection (type 5523/115, 5523/125, 5523/215, 5523/225, 5523/265, 5523/275)	
Operating voltage	24 VDC
Operating current	1.375 mA
Charging time of the DR Detector battery	maximum 4 hours
Supported sizes	
Supported sizes	15x30 to 43x35 in portrait and landscape orientation
Lifetime	
Expected lifetime for the bucky	10 years

Automatic Exposure Control (AEC) Technical Data

Table 39: Varex AEC ionization chamber

Manufacturer	Varex Imaging Americas Corp. 3835 Carnation Street Franklin Park, IL 60131 U.S.A.
Supported Type	ICX1945B
Description	3-field ionization chamber with electronics
Maximum dose rate	1.250 uGy/s
Exposure time range	1 ms to 6 s
Attenuation equivalent mm Aluminum	0.35mm @ 100kV (no filtration)
Dimensions	45 cm x 45 cm x 0.8 cm (WxLxH)

Table 40: VacuTec AEC ionization chamber

Manufacturer	VacuTec Messtechnik GmbH Dornblüthstrasse 13 D-01277 Dresden, Germany
Supported Type	70 145
Description	3-field ionization chamber with electronics
Exposure dose range	1 to 100 uGy
Exposure time range	1 ms to 10 s
Attenuation equivalent mm Aluminum	< 0.75
Dimensions	45 cm x 45 cm x 0.75 cm (WxLxH)

Manual Collimator Technical Data

Manufacturer	Ralco Via dei Tigli 13/G 20853 Biassono (MB), Italy
Supported type	R 221
Maximum radiation leakage	150 kVp – 4 mA
Inherent filtration	2 mm Aluminum equivalent
Added filtration	0mm Al 2mm Al 1mm Al + 0.1mm Cu 1mm Al + 0.2mm Cu
Maximum field Size at SID of 100 cm	48 cm x 48 cm
Dimensions	27.1 cm x 22.2 cm x 16.7 cm (WxDxH)
Weight	8.4 kg

Automatic collimator technical data

Manufacturer	Ralco Via dei Tigli 13/G 20853 Biassono (MB), Italy
Supported type	R 225 ACS
Maximum radiation leakage	150 kVp – 4 mA
Inherent filtration	2 mm Aluminum equivalent
Added filtration	0mm Al 2mm Al 1mm Al + 0.1mm Cu 1mm Al + 0.2mm Cu
Maximum field Size at SID of 100 cm	48 cm x 48 cm
Dimensions	28.5 cm x 24.4 cm x 20.2 cm (WxDxH)
Weight	11 kg

Dose Area Product Meter (IBA DAP) Technical Data

Manufacturer	IBA Dosimetry GmbH Bahnhofstrasse 5 DE-90592 Schwarzenbruck
Supported Type	120-131 HS/RS485
Dose area product range	(0.1...99999999.99) cGy x cm ²
DAP resolution	0.01 cGy x cm ²
Active area	14.0 cm x 14.0 cm
Dimensions	17.9 cm x 16.6 cm x 1.7 cm (WxDxH)
Weight	approx. 220 g
Equivalent filtration of the ionization chamber at 70 kV	0.31 mm Al

Correction factors for using the DAP meter on high altitude

Environmental conditions	Correction factor
75 kPa (ca. 2500 m) 0° Celcius	1.26
75 kPa (ca. 2500 m) 20° Celcius	1.35
70 kPa (ca. 3000 m) 0° Celcius	1.35
70 kPa (ca. 3000 m) 20° Celcius	1.45

Dose Area Product Meter (VacuTec DAP) Technical Data

Manufacturer	VacuTec Messtechnik GmbH Dornblüthstrasse 13 D-01277 Dresden, Germany
Supported Type	VacuDAP 2004
Dose area product range	(1.0...9999999.9) cGy x cm ²
DAP resolution	0.1 cGy x cm ²
Active area	14.7 cm x 14.7 cm
Dimensions	18.2 cm x 17.7 cm x 1.8 cm (WxDxH)
Weight	270 g
Equivalent filtration of the ionization chamber at 70 kV	0.24 mm Al

Correction factors for using the DAP meter on high altitude

Environmental conditions	Correction factor
75 kPa (ca. 2500 m) 0° Celcius	1.26
75 kPa (ca. 2500 m) 20° Celcius	1.31
70 kPa (ca. 3000 m) 0° Celcius	1.35
70 kPa (ca. 3000 m) 20° Celcius	1.40

Fixed DR Detector

Two types of fixed DR Detectors are supported.

Portable DR detector technical data (mounted fixed in the bucky)

Manufacturer	
Manufacturer DR detector	Vieworks Co., Ltd. (Gwanyang-dong), 41-3, Burim-ro 170beon-gil, Dongan-gu, Anyang-si, Gyeonggi-do, Korea
Distributor DR detector	Agfa NV Septestraat 27, B-2640 Mortsels - Belgium
Original manufacturer model name	
XD 17	FXRD-4343VAW
XD*17	FXRD-4343VAW PLUS
Electrical connection	
Power adapter with USB Type-C cable	DC 18 V, max. 2.78 A
Power consumption	max. 24 W
Network connection	
Wireless connection	IEEE 802.11n/ac (2.4 GHz/5 GHz)
Environmental conditions (during normal operation)	
Room temperature	between 0 °C and +40 °C
Humidity (non condensing)	between 5% and 90% RH (non-condensing)
Atmospheric pressure	between 700 hPa and 1060 hPa
Environmental conditions (during storage and transport)	
Temperature (ambient)	between -15 °C and +55 °C
Humidity (non condensing)	between 5% and 90% (non-condensing)
Atmospheric pressure	between 500 and 1060 hPa
Image acquisition	
Image acquisition time (minimum cycle time)	4 s
Conversion screen	CsI
Pixel size	140 µm
Active pixel matrix	3072 x 3072
Effective pixel matrix	3048 x 3048
Detector type	amorphous silicium

Active area size	430 mm x 430 mm
Effective area size	426.7.0 mm x 426.7 mm

Fixed DR detector technical data

Manufacturer	
Manufacturer DR detector	Varex Imaging Corporation, 1678 So. Pioneer Rd, Salt Lake City, UT 84104, USA
Supported models	
4343R (part number 7965)	CsI conversion screen
4343R (part number 7964)	GOS conversion screen
Electrical connection	
Operating voltage	90-240 V (AC)
Mains fuse protection	6A
Mains frequency	47-63 Hz
Power consumption	
Maximum power consumption	45 W
Warming-up time	
	1 hour
Throughput	
Maximum number of image acquisitions	150 acquisitions per hour
Pixel matrix	
Pixel size	139 µm (H,V)
Pixel matrix	3072(H) x 3072(V)
Active pixel matrix	3056(H) x 3056(V)
Fill factor	100 %
Detector type	Amorphous Silicon
Active area size	42,7 cm (H) x 42,7 cm (V)

Reliability	
Estimated product life (if regularly serviced and maintained according to Agfa instructions)	100 000 RAD

Fixed DR detector technical data

Manufacturer	
Manufacturer DR detector	THALES AVS FRANCE SAS 460 Rue du Pommarin – BP122 38430 MOIRANS France
Supported models	
Pixium RAD 4343 C (Pixium 4343RC) Pixium RAD 4343 C-E	CsI conversion screen
Pixium RAD 4343 G (Pixium 4343RG) Pixium RAD 4343 G-E	GOS conversion screen
Electrical connection	
Operating voltage	+24V 3.5A DC
Warming-up time	
	5 minutes
Throughput	
Maximum number of image acquisitions	150 acquisitions per hour
Reliability	
Estimated product life (if regularly serviced and maintained according to Agfa instructions)	100 Gy

Pixel matrix	Pixium RAD 4343 C	Pixium RAD 4343 G	Pixium RAD 4343 C-E	Pixium RAD 4343 G-E
Pixel size	148 µm (H,V)			
Pixel matrix	2880(H) x 2880(V)			
Active pixel matrix	2869(H) x 2874(V)		2860(H) x 2874(V)	
Fill factor	100 %			

Detector type	Amorphous silicon	
Active area size	426.6 mm (H) x 425.4 mm (V)	426.24 mm (H) x 426.24 mm (V)

Fixed DR detector environmental conditions

Pixium RAD 4343 C

Environmental conditions (during normal operation)		
Temperature (ambient)	between 15° and 35° Celsius	
Humidity Atmospheric pressure Maximum altitude	Refer to environmental conditions of the X-ray system	
	minimum	maximum
Distance to calibration temperature	-6 °C	+6 °C
Distance to calibration pressure	-100 mbar	+100 mbar

Pixium RAD 4343 C-E

Environmental conditions (during normal operation)		
Temperature (ambient)	between 15° and 35° Celsius	
Humidity Atmospheric pressure Maximum altitude	Refer to environmental conditions of the X-ray system	
	minimum	maximum
Distance to calibration temperature	-10 °C	+10 °C
Distance to calibration pressure	-100 mbar	+100 mbar

Pixium RAD 4343 G, Pixium RAD 4343 G-E

Environmental conditions (during normal operation)		
Temperature (ambient)	between 15° and 40° Celsius	
Humidity Atmospheric pressure Maximum altitude	Refer to environmental conditions of the X-ray system	

	minimum	maximum
Distance to calibration temperature	-10 °C	+10 °C
Distance to calibration pressure	-100 mbar	+100 mbar

Related information

[Environmental conditions](#) on page 206

Portable DR detector technical data

Refer to the DR Detector User Manual.

NX workstation technical data

Electrical connection	
Operating voltage	90 – 263 VAC
Mains fuse protection	5.5 A
Mains frequency	47 – 63 Hz
Power consumption	
Maximum power consumption	320 W
Power consumption during standby (incl monitor)	32 W
Power consumption	45 W

DR Generator Sync Box technical data

Model name	DR Generator Sync Box
Type number	5400/516
Labeling	
Dimensions	
Depth	21.5 cm
Width	33.5 cm
Height	6.5 cm
Weight	3.2 kg
Electrical connection	100-240 V AC, 50/60 Hz
Estimated product life	7 years

Remarks for HF-emission and immunity

It is hereby certified that the device has interference suppression according to the EN 55011 Class A as well as the FCC Rules CFR 47 Part 15 Class A.

This device was tested for a normal hospital environment as described above.

The user of the device should ensure that it is used in such an environment.

This equipment has been tested and found to comply with the limits for a Class A digital device, pursuant to part 15 of the FCC Rules. These limits are designed to provide reasonable protection against harmful interference when the equipment is operated in a commercial environment. This equipment generates, uses and can radiate radio frequency energy and, if not installed and used in accordance with the instruction manual, may cause harmful interference to radio communications. Operation of this equipment in a residential area is likely to cause harmful interference in which case the user will be required to correct the interference at his own expense.



Warning: This device is intended for use by healthcare professionals only. This device may cause radio interference or may disrupt the operation of nearby equipment. It may be necessary to take mitigation measures, such as re-orienting or relocating the device or shielding the location.



Warning: The HF-emission and immunity can be influenced by connected data cables depending on length and the manner of installation.

This device is intended for operation in the electromagnetic environment given below. The user of the device should ensure that it is used in such an environment.

RF Emission Measurements	Agreement	Electromagnetic Environment Guidelines
High frequency RF emissions in accordance with CISPR 11	Group 1	The device uses high frequency energy exclusively for its internal functions. For this reason, its high frequency RF emission is very low and it is improbable that neighboring electronic equipment will be disrupted.
High frequency RF emissions in accordance with CISPR 11	Class A	The emissions characteristics of this equipment make it suitable for use in industrial areas and hospitals (CISPR 11 class A). If it is used in a residential environment (for which CISPR 11 class B is normally required) this equipment might not offer adequate protection to radio-frequency communication services. The user might need to take mitigation measures, such as relocating or re-orienting the equipment.
Harmonic emission in accordance with IEC 61000-3-2	Class A	
Voltage fluctuations / flickering in accordance with IEC 61000-3-3	Fulfilled	

DR 400 is used in a professional healthcare facility / radiological environment. Environmental conditions are stated in the user manual.

This device was tested for a professional healthcare environment as described above. Nevertheless the HF-emission and immunity can be influenced by connected data cables depending on length and the manner of installation.

Resistance to Jamming Test	Test level of professional medical equipment and basic EMC standards	Electromagnetic Environment Guidelines
Discharge of static electricity in accordance with IEC 61000-4-2	± 8 kV contact discharge $\pm 2, 4, 8, 15$ kV air discharge	Floors should consist of wood, concrete or ceramic tiles. The relative humidity must be at least 30%, if the floor is made of synthetic material.
Fast transient electrical disturbance variables / bursts in accordance with IEC 61000-4-4	± 2 kV mains ± 1 kV data lines	The quality of the voltage supplied should correspond to a typical commercial or clinical environment.
Impulse voltages (surges) in accordance with IEC 61000-4-5	± 1 kV line-line voltage ± 2 kV line-ground voltage	The quality of the voltage supplied should correspond to that of a typical commercial or clinical environment.
Voltage breakdown, short term interruptions and variations in the voltage supplied in accordance with IEC 61000-4-11	<ul style="list-style-type: none"> • $0\% U_r$ for $\frac{1}{2}$ period • $0\% U_r$ for 1 period • $70\% U_r$ (30% breakdown of U_r) for 25 periods at 0° • $0\% U_r$ for 250 periods 	<p>The quality of the voltage supply should correspond to that of a typical commercial or clinical environment.</p> <p>If the user wants the device to work continuously, even when the energy supply is interrupted, it is recommended to use an energy supply free of interruptions or a battery.</p>
Magnetic field at the supply frequency (50/60 Hz) in accordance with IEC 61000-4-8	30 A/m	Magnetic field at the network frequency should correspond to the typical values as they are in a commercial and clinical environment.
REMARK : U_r is the alternating current in the network_ before the application of the test level.		

This device is intended for operation in the electromagnetic environment given below. The user of the device should ensure that it is used in such an environment.

Tests of Resistance to Disruption	Test level of professional medical equipment and basic EMC standards	Electromagnetic Environment Recommended protective distance:
Conducted high frequency disturbance variables in accordance with IEC 61000-4-6	3 V 150 kHz to 80 MHz 6 V within ISM bands	
Radiated high frequency disturbance variables in accordance with IEC 61000-4-3	3 V/m 80 MHz to 2.7 GHz	

RF communication	Refer to the section "Immunity to RF wireless communication equipment"	
		<p>Disruptions are possible near devices that carry the following symbol:</p> 

The field strength of stationary transmitters, such as base stations of radio telephones, mobile broadcasts for rural areas, amateur stations, and AM and FM radio transmitters, cannot be precisely predetermined theoretically. An investigation of the location is recommended, to ascertain the electromagnetic environment as a result of stationary high frequency transmitters. If the field strength of the device exceeds the test level given above, the device must be observed with regard to its normal operation at each place of use. In case of unusual performance characteristics, it can be necessary to take additional measures, such as the re-orientation of the device, for example.

This device is intended for operation in an electromagnetic environment in which the radiated high frequency disturbance variables are monitored. The user of the device can help to prevent electromagnetic disruptions by maintaining the minimum distances between portable and mobile high frequency communication equipment (transmitters) and the device as recommended below, in accordance with the maximum output power of the communications equipment. See also the section with precautions on EMC.

Recommended Protective Distances between Portable and Mobile High Frequency Communication Equipment and the Device			
Rated Power of the Transmitter W	Protective Distance in accordance with RF emission Frequency m		
	150 kHz to 80 MHz $d = 1.0 \sqrt{P}$	80 MHz to 800 MHz $d = 0.3 \sqrt{P}$	800 MHz to 2.7 GHz $d = 0.3 \sqrt{P}$
0.01	0.1	0.05	0.05
0.1	0.32	0.1	0.1
1	1.0	0.3	0.3
10	3.2	1.0	1.0
<p>The distance can be determined through the equation for each respective column.</p> <p>P is the rated power of the transmitter in watts (W) according to the manufacturer information on the transmitter, only for transmitters where the rated power is not mentioned in the above table.</p> <p>REMARK : These Guidelines may not be relevant in all situations. The dispersion of electromagnetic waves is influenced by absorption and reflections from buildings, objects and people.</p>			

- [Immunity to RF wireless communication equipment](#) on page 232
- [Precautions on EMC](#) on page 233
- [Cables, transducers and accessories](#) on page 234
- [Maintenance on EMC relevant parts](#) on page 236

Related information

[Cables, transducers and accessories](#) on page 234

Immunity to RF wireless communication equipment

ISM Band (MHz)	Service	Distance (m)	Immunity test level (V/m)
300-390	TETRA 400	0.3	27
430-470	GMRS 460; FRS 460	0.3	28
704-787	LTE Band 13, 17	0.3	9
800-960	GSM 800/900; TETRA 800, IDEN 820; COMA 850; LTE Band 5	0.3	28
1700-1990	GSM 1800; COMA 1900; GSM 1900; DECT; LTE Band 1, 3, 4, 25; UMTS	0.3	28
2400-2570	Bluetooth; WLAN; 802.11 b/g/n; RFID 2450; LTE Band 7	0.3	28
5100-5800	WLAN 802.11 a/n	0.3	9

Precautions on EMC



Warning: Use of this equipment adjacent to or stacked with other equipment should be avoided because it could result in improper operation. If such use is necessary, this equipment and the other equipment should be observed to verify that they are operating normally.



Warning: Portable RF communications equipment (including peripherals such as antenna cables and external antennas) should be used no closer than 30 cm (12 inches) to any part of the system, including cables specified by the manufacturer. Otherwise, degradation of the performance of this equipment could result.



Warning: The DR detectors might be interfered with by other equipment.

Cables, transducers and accessories

Cables, transducers and accessories which were tested and found to comply with the collateral standard IEC60601-1-2 (EMC):



Caution: Use of accessories, transducers and cables other than those specified or provided by the manufacturer of this equipment could result in increased electromagnetic emissions or decreased electromagnetic immunity of this equipment and result in improper operation.

from; to	type; maximum length	remark
Transfer point table; transfer point wall stand	10 x AWG21 (0.5 mm ²) ; 20 m	unshielded
control room (light push button); table input terminal	2 x AWG21 (0.5 mm ²); 15 m	not delivered with the system
control room (lamp red); table input terminal	2 x AWG18 (1.0 mm ²); 15 m	not delivered with the system
control room (lamp yellow); table input terminal	2 x AWG18 (1.0 mm ²); 15 m	not delivered with the system
control room (door contact); table input terminal	2 x AWG18 (1.0 mm ²); 15 m	not delivered with the system
control room (Com A); table input terminal	9 pin sub D; 20 m	shielded
control room (Com B); table input terminal	Standard RS-232 cable (9 pin sub D); 20 m	shielded
control room (ground); table input terminal	1 x AWG8 (10 mm ²) ; 15 m	mandatory
Table output terminal (x8 24V, light push button, double exposure protection); wall stand input terminal	10 x AWG21 (0.5 mm ²); 20 m	mandatory
table output terminal (230 V); wall stand input terminal	3 x AWG18 (1.0 mm ²); 20 m	mandatory
table output terminal (AEC); wall stand input terminal	CAT 5e (SF/UTP); 20 m	shielded mandatory

from; to	type; maximum length	remark
table output terminal (ground); wall stand input terminal	1 x AWG8 (10 mm ²); 20 m	mandatory
Optional		
control room (DR Generator Sync Box 1); table input terminal (Sync 01)	9 pin sub D (Pin 9 is not connected); 20 m	unshielded
control room (DR Generator Sync Box 2); table input terminal (Sync 02)	9 pin sub D (Pin 9 is not connected); 20 m	unshielded
control room (DR Generator Sync Box 1); wall stand input terminal (Sync 03)	9 pin sub D (Pin 9 is not connected); 20 m	unshielded
control room (DR Generator Sync Box 2); wall stand input terminal (Sync 04)	9 pin sub D (Pin 9 is not connected); 20 m	unshielded
DX-D Fixed DR Detector or DR Detector I/O box; NX workstation	CAT 6 SF/UTP; 40 m	shielded (no connectors allowed)
table output terminal Aux.;; control room NX Workstation	Cat 5e; 15 m	shielded
table output terminal; wired hand control	01090350F; 1.8 m	unshielded, optional

For type 5520/200 only

from; to	type; maximum length	remark
table output terminal; wall stand input terminal (CAN)	9 pin sub D; 20 m	shielded

Maintenance on EMC relevant parts

Concerning the EMC safety of the DR 400 device, no relevant parts could be inspected by the operator. EMC relevant parts will be inspected from AFGA service engineer within the regular service interval until the end of lifetime. The needed verifications are described in the service manual.