



User's Manual



Equipment: **DR 100e**
Version: **Film/CR**
Model: **6012/101 Fixed Column**
6012/102 Rotating Column
File: **224302-22-01**
Language: **EN**
Revision: **0.1**
Date: **04/2023**

Page intentionally left blank

1	CREDITS.....	5
1.1	Compliance.....	5
1.2	Manufacturer	5
1.3	Distributor	5
1.4	Publishing details	5
1.5	Copyright.....	5
1.6	Information about User's Manual	6
1.7	Compatibility.....	7
1.8	Final destination	7
1.8.1	Indications/contraindications.....	7
1.9	Training	7
2	SAFETY.....	8
2.1	Warnings and precautions	8
2.2	Electrical Safety	9
2.3	Mechanical safety.....	9
2.4	Protection against explosions	10
2.5	Fire safety	10
2.6	Electrostatic discharge (ESD).....	10
2.7	Electromagnetic compatibility (EMC)	11
2.7.1	Warning and Safety Precautions for Electromagnetic Compatibility	11
2.8	Protection against ionizing radiations.....	13
2.9	Laser light source	13
2.10	Labeling.....	14
2.10.1	Equipment labels.....	14
2.10.2	Packaging labels.....	17
2.10.3	Collimator labels	18
2.10.4	Serial Number Labels.....	19
3	MAINTENANCE, CLEANLINESS AND DISPOSAL	21
3.1	Checks by the user.....	21
3.2	Cleaning the equipment.....	21
3.3	Disinfection	22
3.4	Periodic maintenance.....	22
3.4.1	Repairs	22
3.5	Disposal.....	23
4	COMPONENTS IDENTIFICATION.....	24
4.1	Usability	24
4.2	Overview	25
4.3	Safety devices.....	27
4.4	Movements	27
4.5	Collimator.....	28
4.6	User interface	28
4.7	X-ray generator control panel.....	29
4.8	Display	30
4.9	Light signals	30
4.10	Acoustic signals.....	30
5	MESSAGES.....	31
6	TRANSPORT.....	33
6.1	Transport position.....	33
6.2	Moving the equipment.....	34
6.2.1	Hanger for the leaded apron	34

7	FUNCTIONING.....	35
7.1	Start up	35
7.2	Positioning	37
7.3	Exposures	39
7.3.1	Free exposure	39
7.3.2	Exposures in Programmed Anatomic mode (APR)	39
7.3.3	APR data table.....	41
7.4	Operation mode	43
7.4.1	After the exposure	45
7.5	Optional: radiography with examination table or Potter Bucky grid	46
7.6	Optional : DAP meter	47
7.7	Optional: data printing	48
7.8	Use end	49
8	TECHNICAL SPECIFICATIONS	50
8.1	Electrical data	50
8.2	Environmental conditions	50
8.3	Total filtration of the equipment	50
8.4	Mechanical data	51
8.5	Operation data	54
8.6	Radiological data	55
8.6.1	kV-mAs relationship	55
8.7	X-ray group	56
8.7.1	Monobloc	56
8.7.2	X-ray tube	58
8.8	Collimator	59
8.9	Optional: Dose Meter	60
8.9.1	Thermal Dose Meter Printer	60
8.10	Optional: Remote exposures control	61
9	ABBREVIATIONS LIST	62
10	CONFIGURATION AND ACCESSORIES	63
11	DOCUMENT STATUS	65

1 CREDITS

1.1 Compliance



This medical device is in compliance with the Medical Devices Regulation (UE) 2017/745 and its revised versions.

The medical device, hereafter called equipment, has been classified in class IIb according to annex VIII - item III Rule 10 of the directive mentioned above.

1.2 Manufacturer

The Manufacturer of the equipment is:

TECHNIX S.P.A.

via E. Fermi, 45

24050 Grassobbio, BG (Italy)

Tel.: +39 (0)35 3846611

Fax: +39 (0)35 335675

Web: <http://www.technix.it>

e-mail: technixd@technix.it

Information about the compliance can be required to the Manufacturer.

1.3 Distributor

The Distributor of the equipment is:

Agfa N.V.

Septestraat 27

B-2640 Mortsel - Belgium

1.4 Publishing details

Published by the Manufacturer.

The Manufacturer reserves the right to modify this User's Manual and the equipment here described.

The equipment specifications are subject to variations without notice. Nothing written in this User's Manual can be considered as an offer, warranty, promise or contractual condition, nor should it be so.

1.5 Copyright

Translations from the original instructions in Italian language.

No part of this User's Manual may be reproduced or transmitted in any form without permission in writing from Manufacturer.

The software included in the equipment belongs to the Manufacturer. Upon receipt of the equipment, the user acquires only the right to use the software.

This right is neither exclusive nor transferable.

It is also necessary to seek a written permission to the Manufacturer before making changes for the use of the equipment for purposes other than those established.

1.6 Information about User's Manual

The purpose of this User's Manual is to provide a valid resource in order to ensure a safe and efficient use of the described equipment to the users.

Before starting up the equipment, it is necessary to read the User's Manual, note and strictly respect all the notices indicating Warning and Precaution messages.

Pay particular attention to information and procedures in the paragraph "Safety".

User's Manual is an integral part of the equipment. It must be kept near the equipment, so that it is possible to consult it at any minute.



A WARNING message indicates a potential serious outcome, critical event or safety risk a warning can cause death or serious injuries to the user and to the patient.



This equipment generates ionizing radiation. Before proceeding with x-ray exposure make sure that the necessary safety measures against radiation have been adopted



A PRECAUTION message indicates where it is necessary particular attention to ensure safe and efficient use of the equipment. The non-observance of a precaution message can cause slight or moderate personal injuries, damages to the equipment or to other goods, and expose to a possible remote risk of more serious injury and/or environmental pollution.



This indication signals particular suggestions, for example to help the user or to improve an operative sequence.

(A)

Reference to position in the figure.

"EMERGENCY BUTTON PRESSED"

Display messages are formatted in double quotes and in capital letters.

In the figures/photos, the messages are displayed in English language, while in the text there is their translation in the language of the manual.

1. Perform visual checks
2. Switch on the unit
3. Switch on the collimator

Operations that must be done step by step by following the logical numbering order.

Even a sequence consisting of a single step is numbered

The User's Manual describes the most complete equipment configuration with the highest number of options and accessories.

Depending on configuration, further use instructions can be supplied together with the equipment. These instructions must be consulted for information about safety, calibration, test procedures and maintenance.

The User's Manual respects the equipment specifications and it is in compliance with all safety norms applicable at the date of publication.

The Manufacturer reserves the right to make changes according to technical progress.

1.7 Compatibility

The equipment described in this User's Manual mustn't be used together with other products or components, except in case they are explicitly indicated as compatible by the Manufacturer.

Information concerning the compatibility with other products can be required by the Manufacturer.

Equipment changes and/or additions must be performed by the Manufacturer or by any third party explicitly authorized by the Manufacturer.

These changes and/or additions must be in compliance with all effective laws and local rules and must be performed with the highest technical capability.



Equipment changes and/or additions performed by skilled people and/or by people who use not approved spare parts, can nullify the equipment warranty.

As for all complicated technical products, maintenance performed by not qualified people and/or by people who use not approved spare parts can cause serious damages to the equipment and personal injuries risks.

1.8 Final destination

Mobile device for X-ray imaging diagnostics with the exception of mammography examinations.

The use of the equipment is reserved exclusively to qualified, trained personnel informed about the risks linked to the use of ionizing radiation.

Its use in professional health service, such as consulting rooms, clinics, hospitals (emergency, patients room, surgery rooms,...) is oriented to:

- Radiology
- Hospitalization
- Emergency ward
- Plaster room
- Pediatrics
- Orthopedics
- Operating theater
- Sports medicine

1.8.1 Indications/contraindications

The equipment is a mobile x-ray device designed for creating x-ray images in radiography.

The equipment must be used only by qualified, trained personnel informed about the risks linked to the use of ionizing radiation on patients both in adulthood and pediatric age.

Considering the x-ray nature, the trained personnel should select and perform the exam by taking care of observing the medical principles of justification and optimization ensuring that the patient advantages exceed the risks.

Specially pregnant women represent a category for which the trained personnel assumes responsibility for carrying out the exam by considering the advantages and the hazards. The exam should be performed by keeping the exposure at the lowest level reasonably achievable compatibly with the required diagnostic quality.

1.9 Training

Equipment users must be properly trained for a safety and effective use before trying to start up the equipment described in this User's Manual.

Contents of the training for this type of equipment are different in every country,

It is up to users to be sure to have received a proper training in compliance with effective laws and local norms.

2 SAFETY

2.1 Warnings and precautions



Expected use and compatibility

Do not use the equipment for purpose other than those for which it is intended. Do not use the equipment with other products than the ones whose compatibility has been recognized by the Manufacturer. The use of the equipment for purposes other than the ones expected or with an incompatible product, can cause serious or mortal physical injuries or wrong diagnosis or therapies. This equipment must be used only in compliance with the safety instructions specified in this User's Manual and exclusively for intended purposes.

Proper training

Do not use the equipment for any application unless you have a proper and adequate training to a safe and efficient use.

If you aren't sure to be able to use this equipment in a safe and efficient way, don't use it. The use of this equipment without proper and adequate training can cause serious or mortal physical injuries or wrong diagnosis or therapies.

Do not use the equipment with the patients if there is no adequate understanding of its capabilities and functions. Using the equipment without an adequate knowledge of its functioning can compromise the efficacy and/or reduce the safety of the patient, the user and other people nearby.

Importance of safety

Do not use the equipment for any application before reading, understanding and assimilating all information about safety, safety and emergency procedures specified in this User's Manual. The use of the equipment without a proper knowledge of safety rules can cause serious or mortal physical injuries, or wrong diagnosis or therapies.

Safety systems

Never try to remove, modify, exclude or obstruct any safety device on the equipment. An intervention on safety devices can cause serious physical injuries or even death.

Maintenance and defects

The equipment should be subject to regular checks by the technical service support of the Manufacturer or by personnel expressly authorized by the Manufacturer, by following a preventive yearly maintenance plan prearranged by the Manufacturer.

If it is sure (or probable) that any part of the equipment is defective or wrong adjusted, don't use it before performing a check by the technical service support.

The use of an equipment with defective parts or adjusted in a wrong way, can expose the user or the patient to ionizing radiations or to other dangers concerning safety. This can cause serious or mortal physical injuries, or wrong diagnosis or therapies.



The user should report any serious incident that has occurred in relation to the device to the manufacturer and the competent authority of the Member State in which the user is established

2.2 Electrical Safety

This equipment is in compliance with safety class I, Type B, in accordance with IEC 60601-1 norm.



Do not remove protections or cables from this equipment, unless it is expressly required in this User's Manual, because inside it there are dangerous electrical voltages. The removal of protections or cables can cause mortal injuries or serious damages to the people.

Protections or cables must be removed only by qualified and authorized technical personnel. Use the equipment only in rooms or areas comply with all applicable laws (or regulations having the force of law), referring to electrical safety of this type of medical device.

Always insulate the equipment from the power supply before proceeding with cleaning or disinfection operations in order to avoid electric shocks.

Equipotential earth connection

The equipment is supplied with an equipotential earth connection point.

The equipment can be used only in areas comply with local electrical safety norms and in environments suitable for medical activities. Besides IEC 60601-1 norm provides instructions about the equipotential earth connection point.

Additional equipotential earth connection

An additional equipotential earth connection is provided because the equipment is movable and the reliability of the main equipotential earth connection point can be insufficient.

It is possible to use this equipment only in rooms comply with IEC norm requirements.



The equipment described isn't protected against liquids seepage. Its classification is IPx0.

2.3 Mechanical safety



Be sure that parts of the body or clothes aren't stuck among moving components of the equipment.

Remove all objects from range of motion of the equipment.

Check that the unused hanging components (monitor and radiogenic complex) are positioned so as not to affect neither the user nor the patients.

It is not possible to transport this equipment while it is working. For a safety transport, switch off the equipment before transporting it and ensure that all system peripherals (monitor, mouse, keyboard, cables etc.) are disconnected.

Do not remove protections or cables from this equipment, unless this operation is expressly requested in this User's Manual.

The equipment includes moving parts. The removal of protections can cause serious or mortal physical injuries to people.

2.4 Protection against explosions



This device mustn't be used in presence of explosive gas or fumes. Do not use disinfectant spray flammable or potentially explosive. The use of this equipment in an unsuitable environment can cause fires or explosions.

2.5 Fire safety



Do not use this equipment in areas where there is a risk of fire.

Do not cover the ventilation openings while the equipment is turned on.

For electrical or chemical fires use only fire extinguisher marked as suitable for such uses. The use of water or other liquids in an electrical fire can cause physical injuries or even death.

Before trying to extinguish the fire, the safety measure to be taken is to separate the equipment from other electric power sources and from all other sources in order to reduce the risk of electrical shocks.

2.6 Electrostatic discharge (ESD)



Always resort to static procedures, protections and appropriate products before opening or during the handling of the equipment. This equipment includes electrostatically sensitive components.

Non-compliance with ESD procedures may cause damages to the components. Such damages to the components are not covered by any warranty.

The electrostatic discharge (ESD) can cause a remarkable voltage that could cause damages to printed circuit boards (PCB) or to other equipment components.

Electrostatic discharge (ESD) damages can accumulate and can initially not be visible, such as a hardware failure, but can reduce performances. Therefore, it is recommended to use proper ESD handling procedures. ESD can be due to low humidity or to the use of electrical equipment on carpets, bedding and clothes.

2.7 Electromagnetic compatibility (EMC)

This equipment complies with international and national laws and regulations relating to electromagnetic compatibility (EMC) in force for this type of product, if it is used for the intended purposes. Such laws and regulations define the electromagnetic emissions level coming from the product and the requested immunity against electromagnetic interferences from external sources. Other electronic products that exceed the limits defined by EMC standards can, in unusual situations, affect on the equipment working.

- Electromedical products request special precautions referring to electromagnetic compatibility (EMC) and must be installed and started up in compliance with EMC information provided in the documentation enclosed.
- The use of accessories and cables other than those specified can cause a higher emission or lowest immunity levels.
- The equipment mustn't be used in proximity of other products or stacked on them and, if this will be necessary, you must check the right functioning.



Mobile phones and laptops

Communications among RF portable and mobile equipments can affect medical equipments. It is recommended to use caution while using such communication devices within the specified radius of electromedical devices

2.7.1 Warning and Safety Precautions for Electromagnetic Compatibility



Increased emission or reduced interference immunity.

Use of unsuitable accessory or lines

- ▶ Exclusive use of the listed accessory or line with the exception of internal original spare part components.

Electric medical equipment is subject to special precautionary measures with regard to EMC and may only be installed and put into operation in compliance with the EMC information contained in the Operating Manual. Portable and mobile radiofrequency communication devices can influence electric medical devices.

Guide and declaration of the manufacturer - Electromagnetic emissions

The equipment is suitable to be used in the specified electromagnetic environment. The purchaser or the user of the equipment should ensure that it is used in an electromagnetic environment as described below:

Emission test	Compliance	Electromagnetic environment
RF emissions CISPR 11	Group 1	This equipment uses RF energy only for its internal operation. So the RF emission is very low and unlikely to cause interference in nearby electronic equipment
RF emissions CISPR 11	Class A	The equipment is suitable for use in all environments except the domestic one and those directly connected to the public low-voltage network that supplies buildings used for domestic purposes.
Harmonic emissions IEC 61000-3-2	Not applicable	
Voltage /flicker fluctuations emissions IEC 61000-3-3	Not applicable	

Guide and declaration of the manufacturer - Electromagnetic immunity

The equipment is suitable to be used in the specified electromagnetic environment. The purchaser or the user of the equipment should ensure that it is used in an electromagnetic environment as described below:

Immunity Test	IEC 60601-1-2 Test level	Compliance level	Electromagnetic environment
Electrostatic discharge (ESD) IEC 61000-4-2	8 kV contact 2/4/8/15 kV air	IEC 60601-1-2 Test Level	The floors must be made of wood, concrete or ceramic tiles. If the floors are covered by synthetic material, the relative humidity should be at least equal to 30%.
Irradiated electromagnetic field IEC 61000-4-3	3 V/m 80 MHz at 2.7 GHz	IEC 60601-1-2 Test Level	The portable and mobile RF communication systems should be used not closed to the equipment parts including the cables. Min. distance 30 cm
Transistors/ rapid electric pulses sequence IEC 61000-4-4	2 kV for power supply lines 1 kV for input/output lines > 3 m	IEC 60601-1-2 Test Level	Mains power quality should be the one of a typical commercial or hospital environment
Transitory overvoltage IEC 61000-4-5	0.5/1 kV differential mode 0.5/1/2 kV standard mode	IEC 60601-1-2 Test Level	Mains power quality should be the one of a typical commercial or hospital environment
Conducted noises caused by RF fields IEC 61000-4-6	3 V 150 kHz at 80 MHz 6V ISM frequencies	IEC 60601-1-2 Test Level	The portable and mobile RF communication systems should be used not closed to the equipment parts including the cables. Min. distance 30 cm
Voltage dips, short breaks and voltage variations on power supply input lines IEC 61000-4-11	0% U_n for 0.5 cycle 0 % U_n for 1 cycle 70 % U_n for 25 cycles 0 % U_n for 5 s	IEC 60601-1-2 Test Level	Mains power quality should be the one of a typical commercial or hospital environment. If the user of the equipment requires continuous operation during the electric power supply breaks, power the equipment with a continuity group or a battery.
Mains frequency (50/60 Hz) of the magnetic field IEC 61000-4-8	30 A/m	IEC 60601-1-2 Test Level	The magnetic fields of the mains frequency should have specific levels for a commercial or hospital environment .



Use of accessories, transducers and cables other than those specified or provided by the manufacturer of this equipment could result in increased electromagnetic emissions or decreased electromagnetic immunity of this equipment and result in improper operation.



Portable RF communications equipment (including peripherals such as antenna cables and external antennas) should be used no closer than 30 cm (12 inches) to any part of the equipment, including cables specified by the manufacturer. Otherwise, degradation of the performance of this equipment could result.

2.8 Protection against ionizing radiations



This equipment generates ionizing radiations (hereinafter called radiations).

Before proceeding with x-ray exposure, be sure that all safety measures in protection against radiations have been taken.

While using the equipment, the examination room personnel have to respect all necessary protection rules. In this context, please observe the following rules:

- To protect patients from radiations, use tools suitable for protection against radiations, as well as the devices supplied together with the x-ray equipment (for example, diaphragm, spacer, filter)
- Always wear protective clothing. Anti-radiation clothing with an equivalent of 0,35 mm of lead can reduce the 99,84% of radiations at 50 kV and the 91,2% at 100 kV.
- If it is necessary to stay in the controlled area, please wear a personal dosimeter. The Manufacturer suggests to define the personal dose that occurs in the workplace under practical conditions and to use it as basis for precautions against radiations.
- Distance represents the more efficient protection against radiations. Please keep the largest possible distance from the exposed object and from x-ray complex.
- Avoid to work in the direct irradiation area; if it isn't possible, please protect yourself, Wear gloves for protection against radiations.
- Always use the lowest collimation of the x-ray area. Check that interested area is completely exposed. The diffused radiation depends largely on the volume of the object exposed.
- Always check that the x-ray field collimation completely covers the measurement range selected.
- Always select the largest possible distance between focal point and skin in order to minimize the dose absorbed by the patient.
- Always select the shortest examination time, in this way the radiation dose is considerably reduced.
- Move the interested area as close as possible to the image intensifier/ cassette / detector. Radiations exposure is reduced and even optimized.
- Always keep in mind that any material interposed along the path of radiation between the patient and the image receiver (for example film) reduces the images quality and increases the dose absorbed by the patient.
- Always check that there is visual and audible communication between the user and the patient during all the examination. If necessary keep the communication using technical means such as an intercom.
- Do not modify or remove safety circuits that under certain conditions prevent the x-ray emission.

2.9 Laser light source



Laser radiation

Radiations potentially dangerous for skin and eyes.

- ▶ Do not stare directly or through optical instruments at the laser beam
- ▶ Do not point the laser beam on the face/eyes of the patient

2.10 Labeling

2.10.1 Equipment labels

Fixed column version

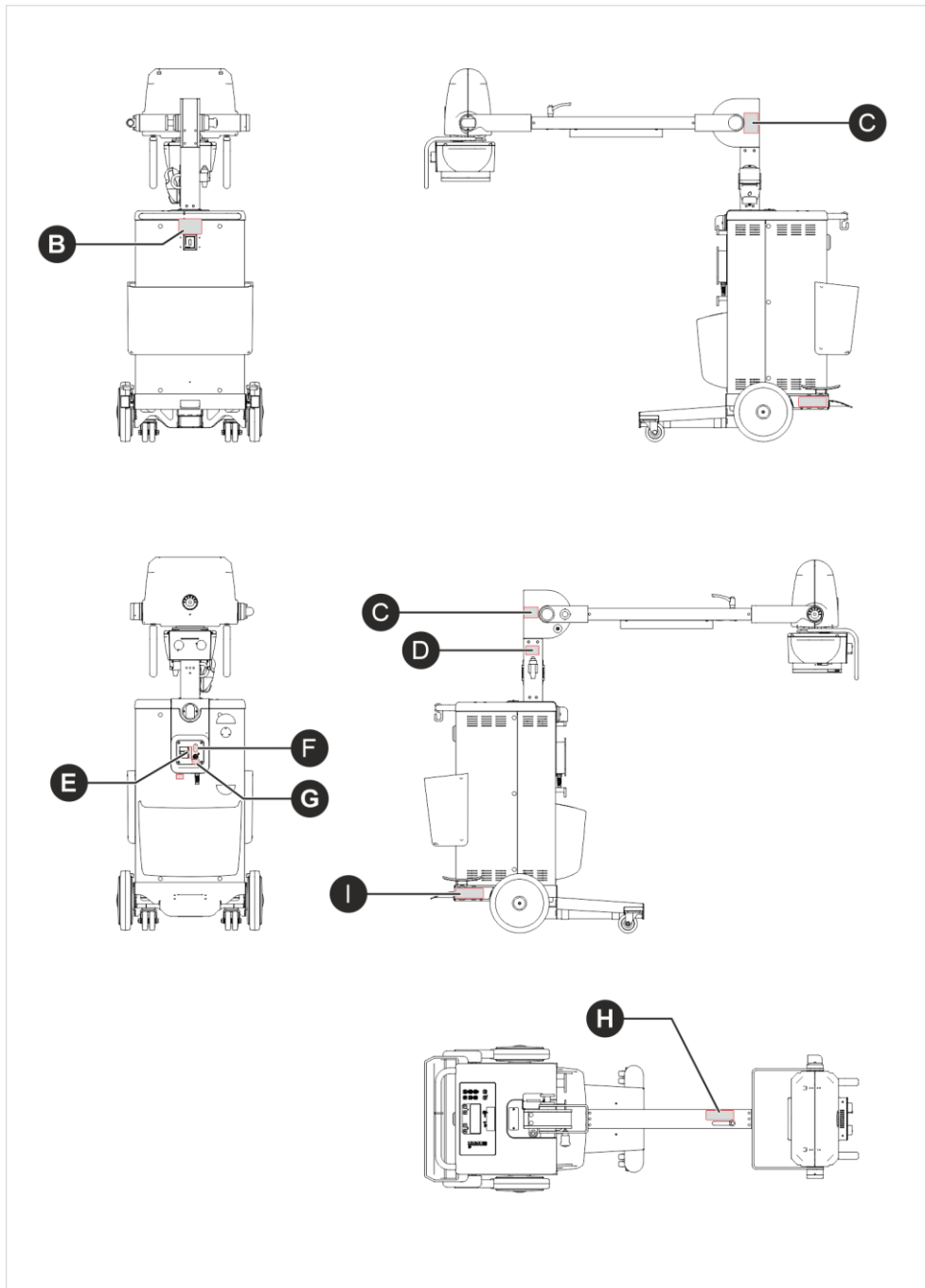

Rotating column version

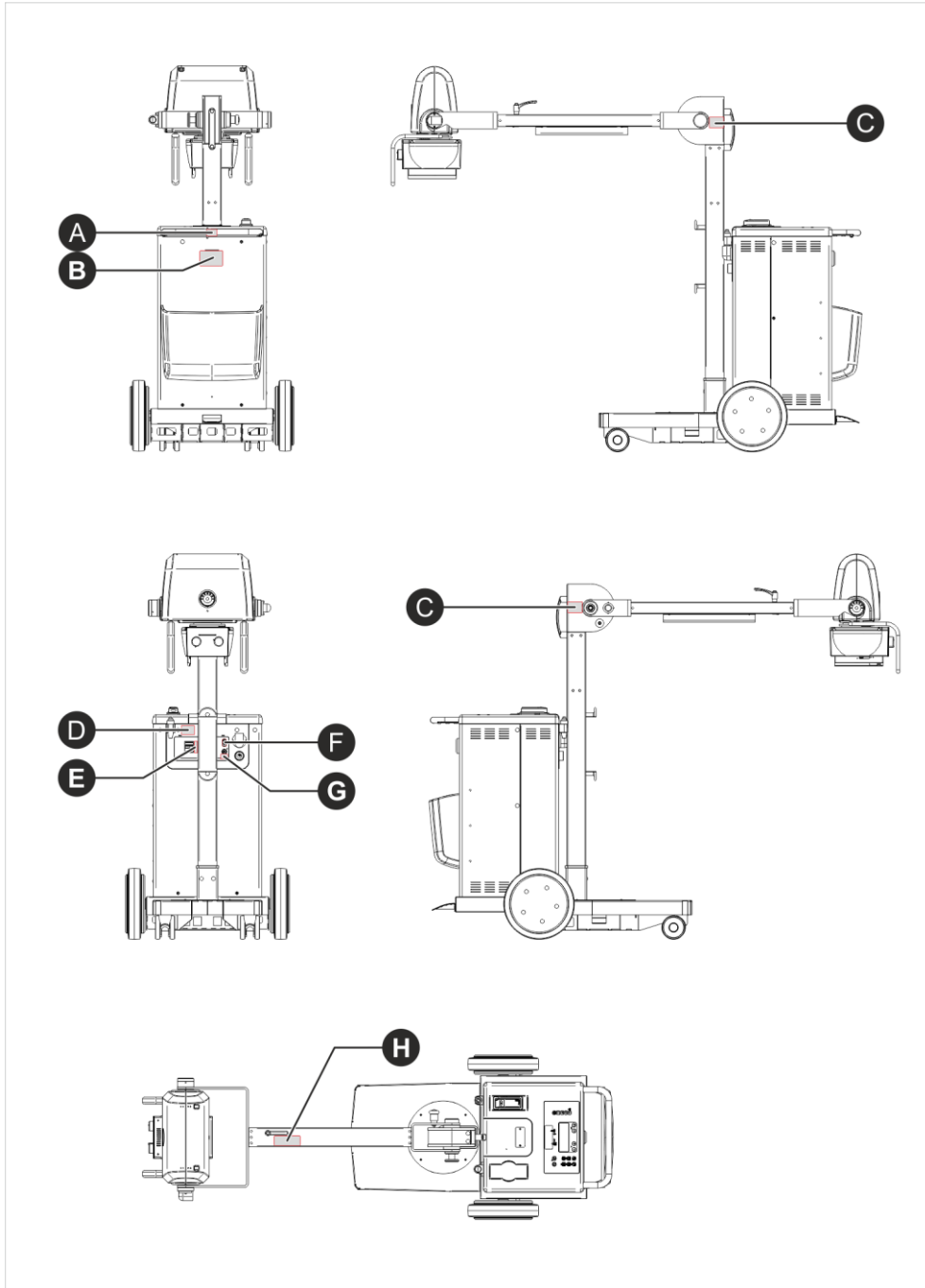

Label description



Pos. **A** - Information label for the transport handle operation

Only for rotating column version

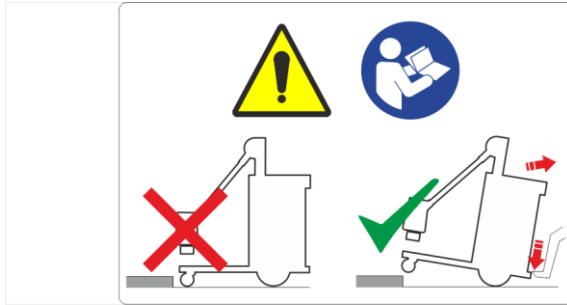

Pos. **B** - Information label for the obstacles overcoming

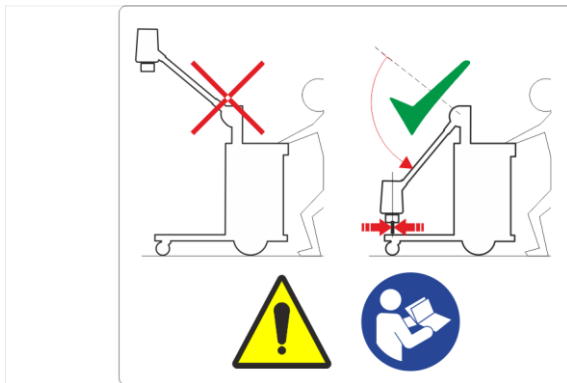

Pos. **C** - Information label for the equipment transport position

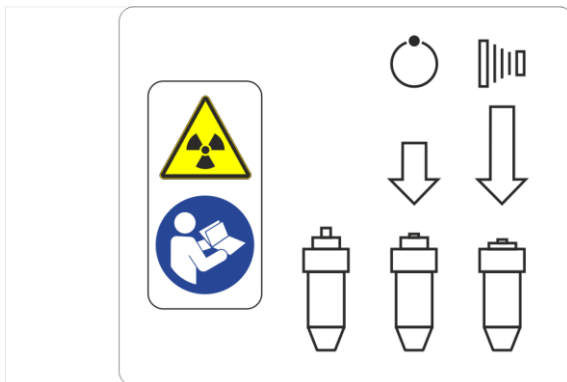

Pos. **D** - Information label for the x-ray handswitch

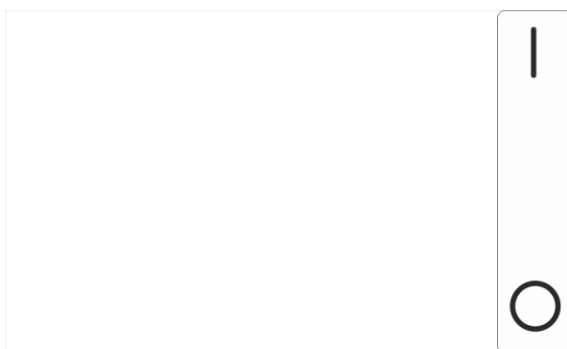

Pos. **E**. - Label of circuit breaker switch ON/OFF position

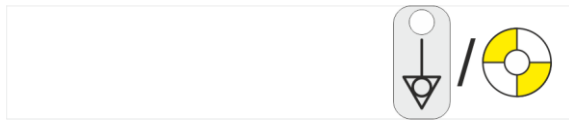

Pos. **F** - Equipotential node label

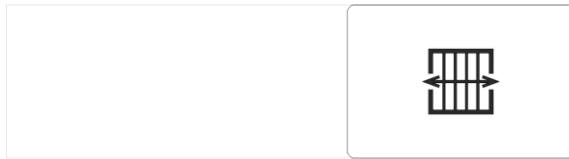

Pos. **G** - Potter connections label

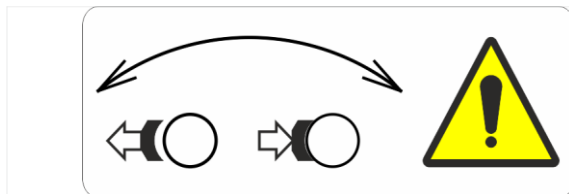

Pos. **H** - Information label for the monobloc rotation lock.

By rotating the knob clockwise, the rotation stops.

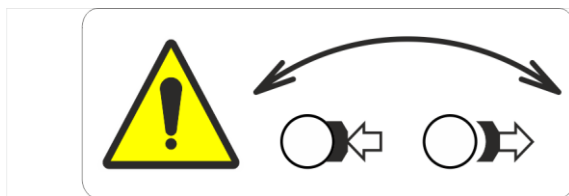

Pos. **I** - Label for the parking brake lock.

By moving the lever of the brake in horizontal position, the parking brake is deactivated.

Only for fixed column version



Label present also on the other side of the equipment.

2.10.2 Packaging labels



Packaging content identification label.



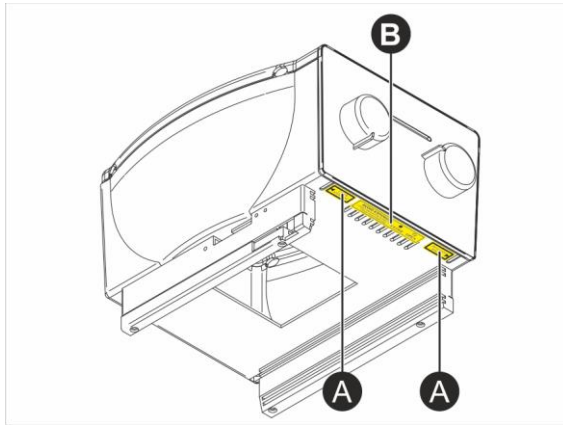

For more information about symbols, refer to the legend of the equipment serial number in par. 2.10.4.

2.10.3 Collimator labels

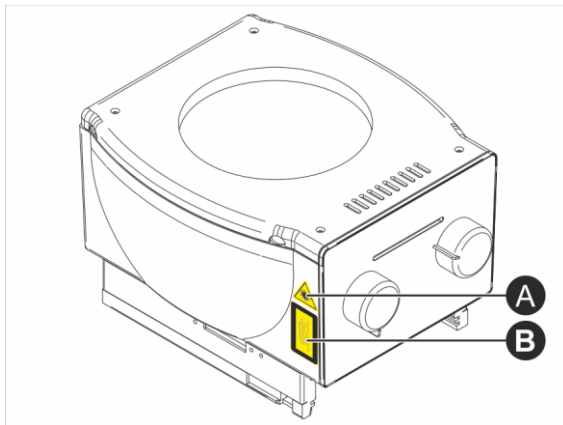

- (A) Laser openings
 - (B) Warning labels
- Avoid the exposure
Radiations are emitted
from this opening



- (A)  Laser radiation symbol
- (B) Warning label:
LED Radiation
Risk group 2 IEC 62471:2006
CAUTION: Do not stare at operating light source.
May be harmful to the eyes.

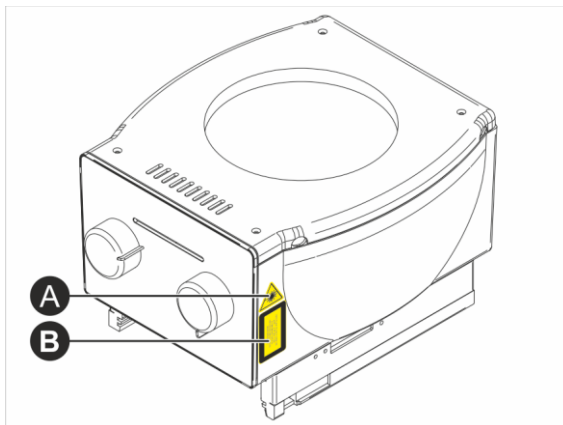

- (A)  Laser radiation symbol
- (B) Warning label:
Laser Radiation
Do not stare into beam
Class 2 LASER product
IEC 60825-1:2007
 $P_o \leq 1\text{mW}; \lambda = 645 \pm 10\text{nm}$

2.10.4 Serial Number Labels

Labels position

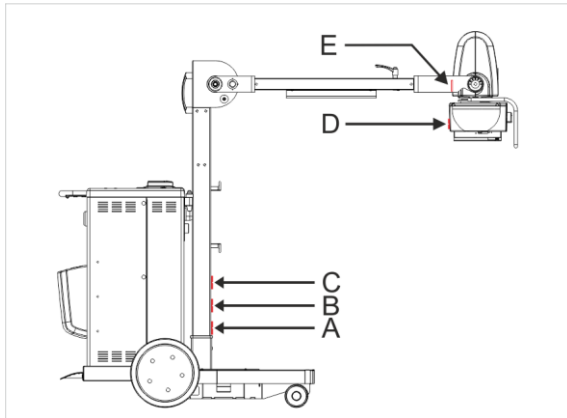

- A - Equipment serial number
- B - UDI label
- C - Equipment weight label
- D - Collimator serial number
- E - Monobloc serial number

A - Equipment serial number

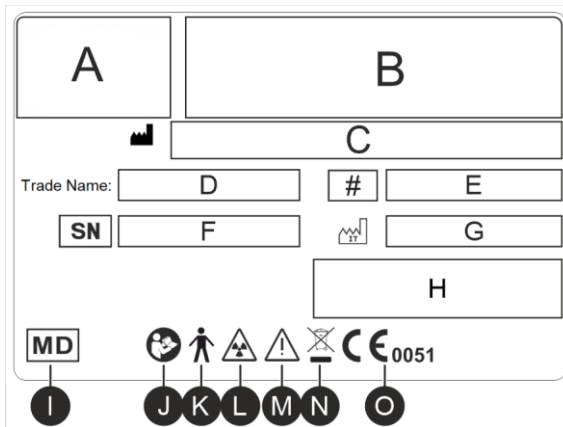

Equipment s/n legend:

- A - Distributor's logo
- B - Name and address of the Distributor
- C - Name and address of the Manufacturer
- D - Equipment model
- E - Equipment version
- F - Equipment serial number
- G - Manufacturing date
- H - Electrical data
- I - Medical Device
- J - Interventionist standard certification
- K - Classification
- L - Ionizing radiation
- M - Warning symbol
- N - WEEE
- O - CE Marking

B - UDI label

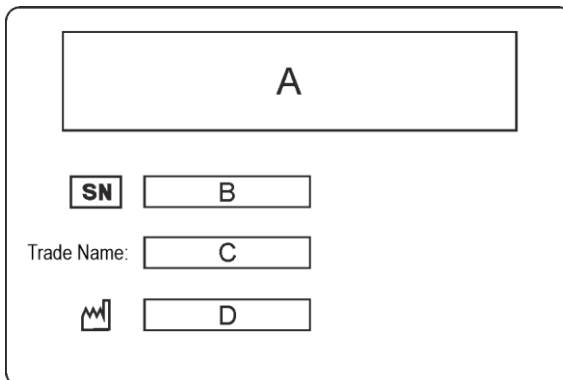

Legend:

- A - Bar code
- B - Equipment serial number
- C - Equipment name
- D - Manufacturing date

C - Equipment weight label

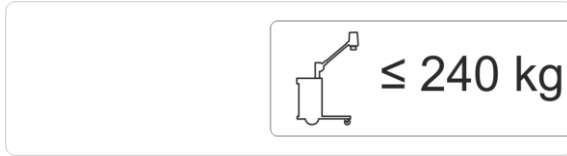

Legend:

- A - Figure of the equipment
- B – Weight (in kg)



The indicated weight is only for example

D - Collimator serial number

A	B
C	D
E	

Legend:

- A - Manufacturer's logo
- B - Manufacturer's name and address, manufacturing date
- C - Model and s/n of the collimator
- D - Filtration data, max. voltage, power supply voltage
- E - Certification logo, warning symbols, classification

E - Monobloc serial number

A	B	C
D	E	
F	G	
H	I	
J		K

Legend of x-ray group serial number:

- A - Manufacturer's logo
- B - Manufacturer's address
- C - EC certification
- D - Monobloc code
- E - Manufacturing date
- F - Monobloc model
- G - Monobloc s/n
- H - XR tube type
- I - X-ray tube s/n
- J - Electric data, foci dimensions and filtration data
- K - WEEE, consult the attached documentation, ionizing radiation

3 MAINTENANCE, CLEANLINESS AND DISPOSAL

3.1 Checks by the user

Before every equipment use, the operator must be sure of its correct operation.

In case of malfunction or fault messages, both during the switching-ON phase and during the standard use, the equipment must be switched OFF, parked in a safe place and the technical service support must be informed.

3.2 Cleaning the equipment



Short-circuit or damage to electronic elements.

Liquids seepage inside the equipment.

- ▶ Always disconnect the equipment from the mains
 - ▶ Don't use disinfectants in spray directly on equipment.
 - ▶ Before cleaning and disinfecting, switch off the system and unplug all devices that can be connected to the equipment
-

Enameled parts and aluminium surfaces must be cleaned only with a damp cloth and a mild detergent and then with a dry woolen cloth.

Never use scouring powders, solvents, abrasives detergents or polishing abrasive.

Do not use a special detergent if its properties are not sure.

Chromed parts must be cleaned only with a dry woolen cloth.

Do not use polishing abrasives.

To protect the finish, use a non-abrasive wax.

Plastic surfaces must be cleaned only with soap and water. When using other cleaning agents (for example with a high alcohol content), the material can become opaque or can break.

3.3 Disinfection



Cross infections/ contaminations.

Missing observance of the hygiene standards.

- ▶ Follow all the policies concerning the control of the personnel infections and equipment.



The cleaning and disinfection techniques both for the equipment and for the environment where it is used must be in compliance with all laws and standards in force in the country where the equipment is installed.

Only personnel trained in the management of cleaning and disinfection of medical devices is authorized to conduct such activities.

Perform regularly cleaning and disinfection operations of the equipment.

The disinfection method used must be in compliance with all laws and norms in force for disinfection and protection against explosions in force in the country where the equipment is installed.

All parts of the equipment suitable for this type of treatment, accessories and connection cables included, can be disinfected with a damp cloth and a proper detergent. Never use disinfecting agents or corrosive sterilizers or solvents.

Do not use a special disinfecting or sterilizing agent if its properties are not sure.

If it is necessary to use non-inflammable and non-explosive sprays, first of all switch off and cool down the equipment.

In this way the vaporized spray can't be attracted by convention currents inside the equipment. Before starting spraying, it is necessary to cover carefully the product with plastic sheeting.

Once all traces of disinfecting spray disappear, it is possible to remove the protective plastic and directly disinfect or sterilize the equipment following the recommended instructions.

After using a spray the user must be sure that every single trace of gas has disappeared before starting up the equipment again.

3.4 Periodic maintenance



Injuries or damages risk

Technical interventions performed by non-authorized personnel.

- ▶ Only skilled and qualified service personnel is authorized to perform technical interventions on the equipment.

The correct working, safety and life of the equipment depend on a correct use from the user and from a plan of technical interventions and periodic maintenance programmed and performed regularly.

The user must agree with the technical service support a yearly plan of maintenance and technical interventions.

3.4.1 Repairs



Injuries or damages risk

Technical interventions performed by non-authorized personnel.

- ▶ Only skilled and qualified service personnel is authorized to perform technical interventions on the equipment.

The equipment includes mechanical parts subjected to wear because of working.

The correct adjustment of electromechanical and electronic complexes affects the working, image quality, electrical safety and the exposure of the patient and the medical personnel to radiations.

3.5 Disposal

The manufacturer wants to make a contribution to environment defense and wants to guarantee a constantly safe and efficient use of this equipment by using a proper support, maintenance and training program.

If the equipment is used correctly and always subjected to proper maintenance, it doesn't represent an environmental risk. However it can include materials that can be potentially harmful for the environment if they are not properly disposed.

The use of such materials is essential for carrying out the equipment functions in compliance with legal requirements and so on.

Final disposal of the equipment

The final disposal is effected when the equipment has been used so that it is no longer usable for the intended purposes.

The return, proper disposal or recovery of this medical equipment must be done in compliance with the European WEEE (Waste Electrical and Electronic Equipment) and / or national requirements.



The equipment or parts of it mustn't be disposed as industrial or domestic waste, but they must be collected separately as special waste. The separate collection for the subsequent forwarding for recycling, treatment and environmentally compatible disposal, helps to avoid possible negative environmental and health effects and to promote recycling of the parts included in the equipment.

Illegal disposal of the equipment involves the application of administrative sanctions according to the current regulations of the country where the equipment is installed.

For information on how to dismantle the inoperative equipments comply with local legislation or contact an authorized representative of the Manufacturer.

4 COMPONENTS IDENTIFICATION

4.1 Usability

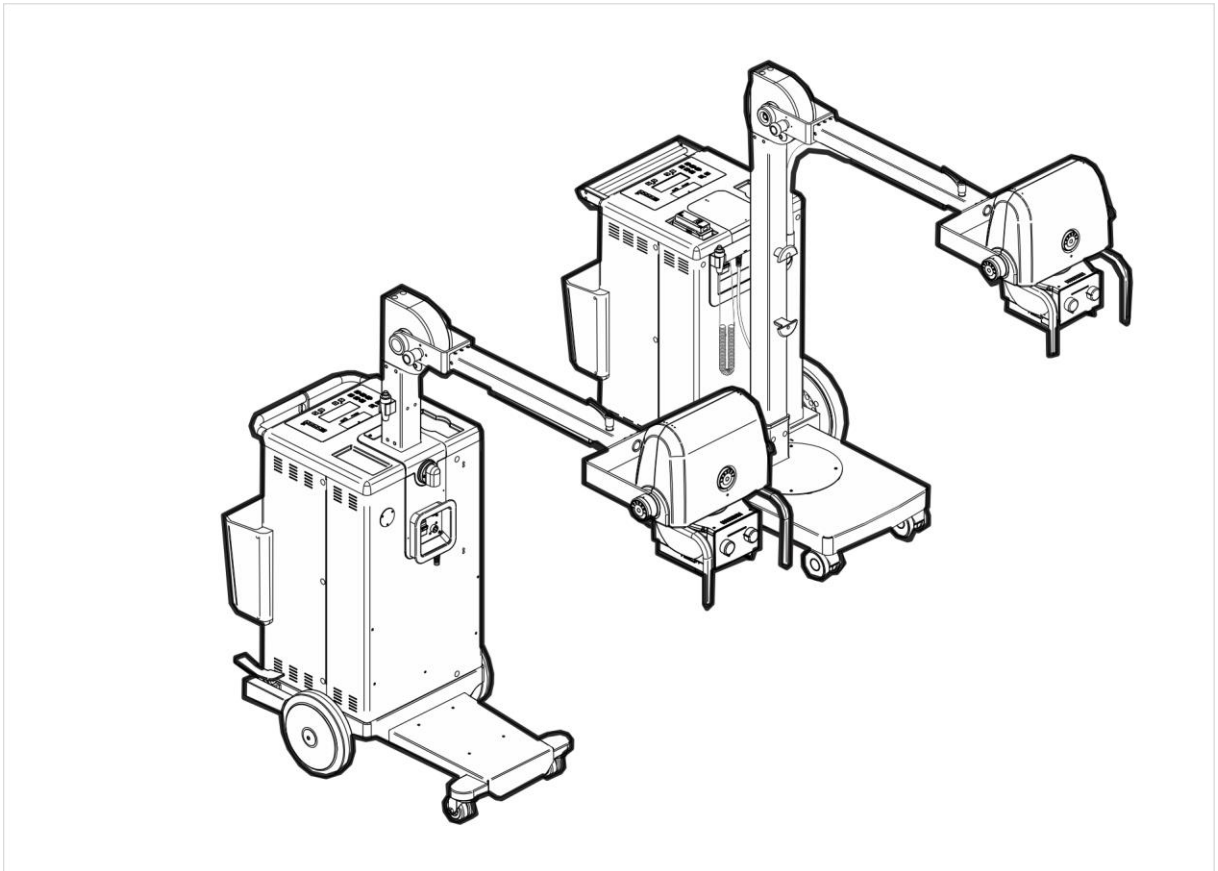

The equipment is used in hospital environment to perform x-ray examinations, in particular in cases when the transport of the patient in a ward with fixed equipment is uncomfortable or not possible.

The equipment allows to perform x-rays on CR or film by setting the most suitable radiological data according to the interested anatomic area. In fact, the number of programmed anatomics and radiological data can be customized (typically during installation) according to requests and operation modes of the hospital.



The hardware shown in the User Manual corresponds to the equipment status at the moment of the delivery.

The Manufacturer reserves the right to make changes based on technical progress.

Design changes (for example of the covers) don't affect neither the functions nor the use of the equipment.

4.2 Overview

Fixed column version

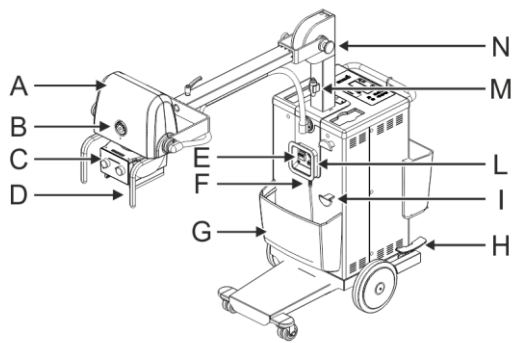

- A - Monobloc
- B - Goniometer
- C - Collimator
- D - Monobloc handle
- E - Circuit breaker/ Equipotential node
- F - Power supply cable
- G - Glove compartment
- H - Pedal brake
- I - Cable reel
- L - Potter interface
- M - Exposure control hand switch
- N - Apron-hanger

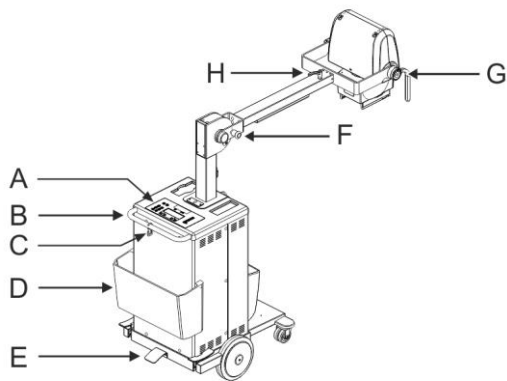

- A - Control panel
- B - Transport handle
- C - Cable holder
- D - Cassette holder
- E - Tilting pedal
- F - Lock of the arm movement during transport
- G - Monobloc rotation movement lock
- H - Goniometer

Rotating column version

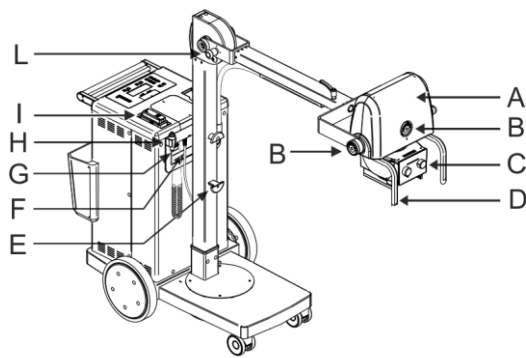

- A - Monobloc
- B - Goniometer
- C - Collimator
- D - Monobloc handles
- E - Cable reel
- F - Mains cable
- G - Circuit breaker switch/ Equipotential node / Potter interface
- H - Exposures control handswitch
- I - Remote exposure control (optional)
- L - Safety lock of arm movement

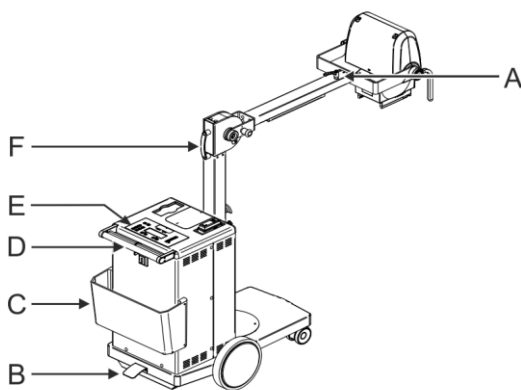

- A - Monobloc rotation lock
- B - Tilting pedal
- C - Cassette holder
- D - Movement handle with dead man parking brake
- E - Control panel
- F - Tilting handle

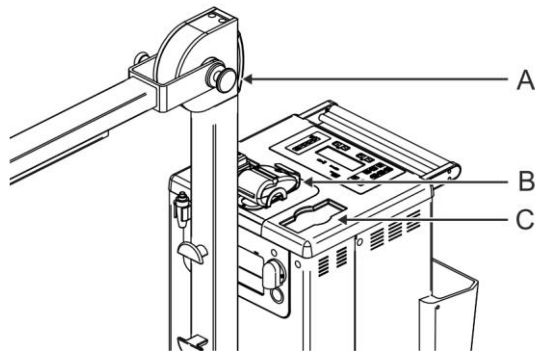

- A - Apron hanger
- B - Dosimeter printer (optional)
- C - Glove compartment

4.3 Safety devices

Circuit breaker

The equipment is protected by a circuit breaker (A) against excessive mains fluctuations.

In case of intervention of the circuit breaker, to restore the working of the equipment it is enough to put back the control of the circuit breaker in "I" position.

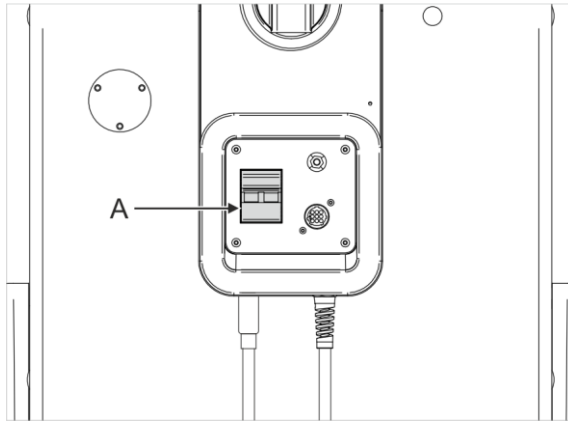

Fixed column version

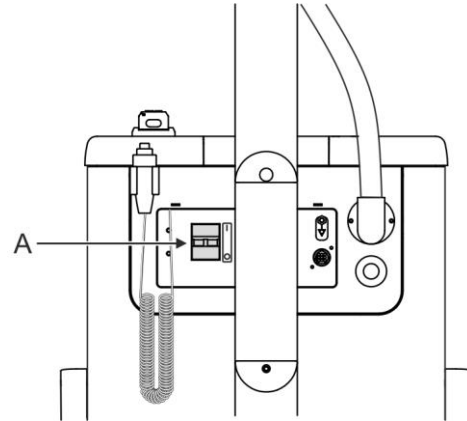

Rotating column version

4.4 Movements

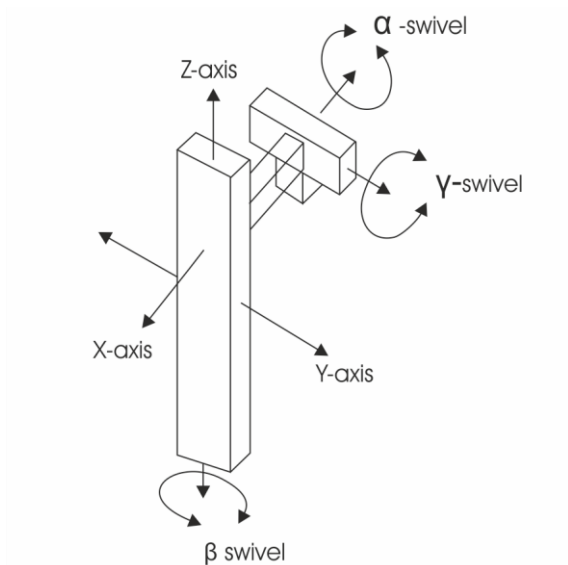

X-axis = Movement of the telescopic arm

Y-axis = n.a.

Z-axis = Vertical movement of the x-ray group

α -swivel = Rotation of x-ray group around X-axis

β -swivel = Rotation of x-ray group around Z-axis

γ -swivel = Rotation of x-ray group around its axis

4.5 Collimator

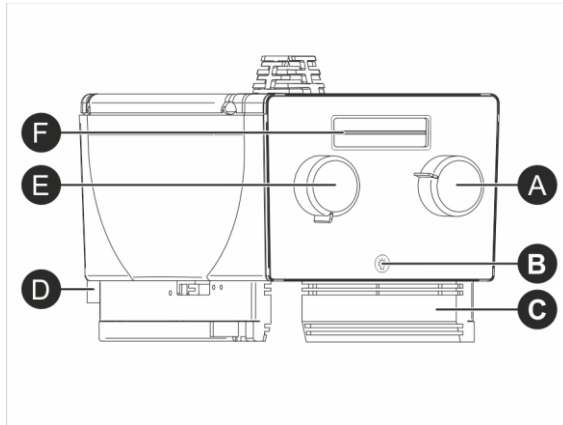

A - Longitudinal collimation

B - Lamp ignition pushbutton and laser pushbutton (optional)

C - Guides for accessories positioning (filters or DAP meter)

D - Tape measure for the measurement of focus-image receptor distance

E - Transversal collimation

F - Disc for filters insertion

4.6 User interface

The interface with the operator consists in a control panel (A).

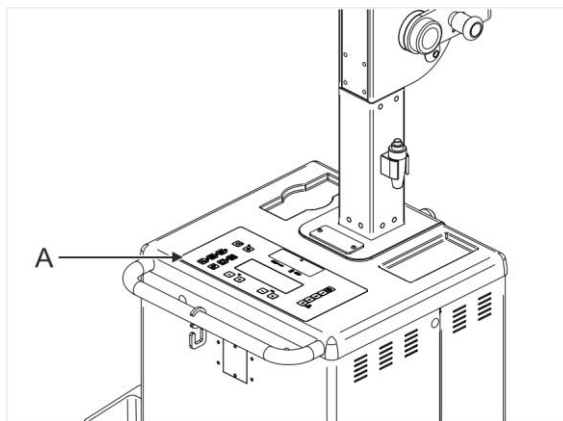

Fixed column version

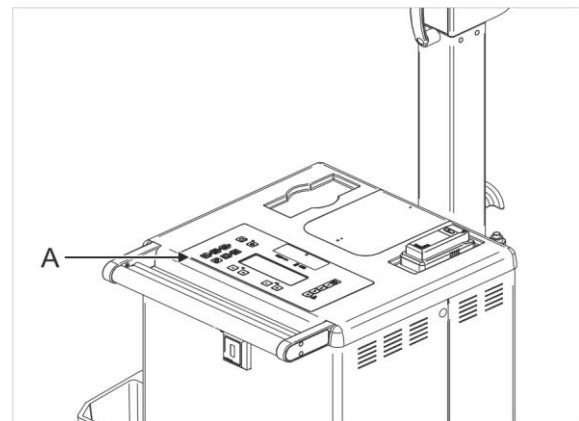

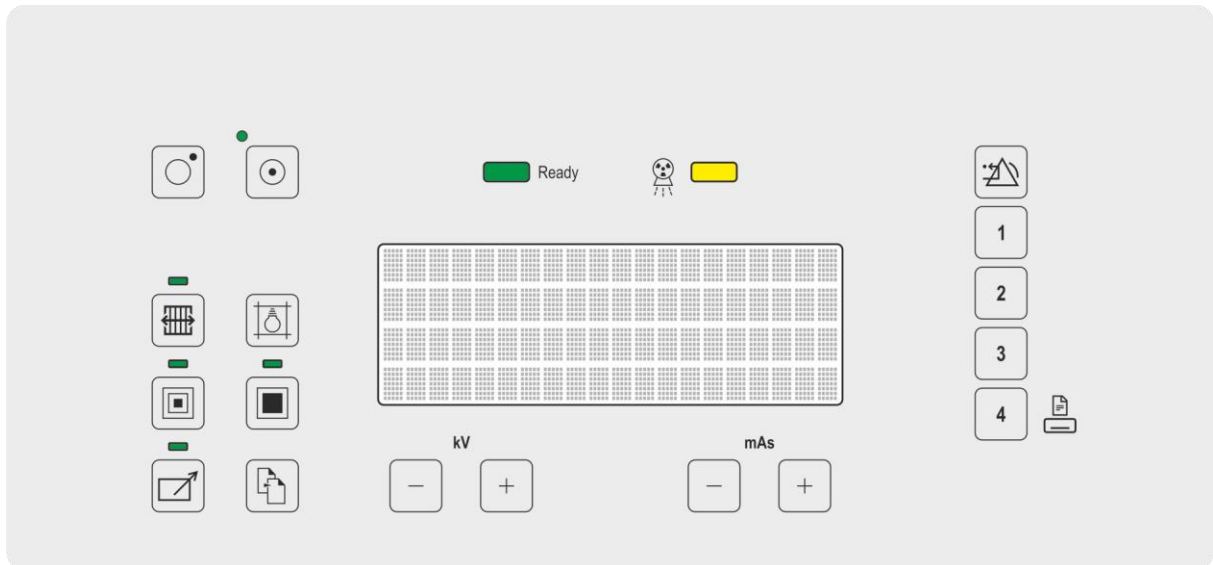

Rotating column version

4.7 X-ray generator control panel



All keys are membrane type

Symbol	Function	Description
	OFF	Equipment OFF
	ON	Equipment ON. The green led indicates that the equipment is connected to the mains and powered.
	POTTER	POTTER selection. The green led ON indicates the performed selection.
	COLLIMATOR	Collimator lamp switching ON. The switching-ON is timed for about 30s.
	SMALL FOCUS	Small focus selection. The led ON indicates the performed selection.
	LARGE FOCUS	Large focus selection. The led ON indicates the performed selection.
	LOCAL / REMOTE	Mode for performing an exposure: local wired control or remote control. The led ON indicates the remote control selection.
	MENU'	APR mode / It scrolls the pages in menus with more pages

Symbol	Function	Description
<div style="text-align: center;">kV</div> 	kV- kV+	It modifies the kV value
<div style="text-align: center;">mAs</div> 	mAs- mAs+	It modifies the mAs value
	RESET	It resets the alarms / It returns to the upper menu

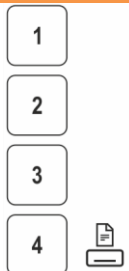

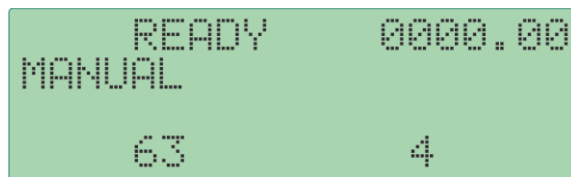

Symbol	Function	Description
	F#	Function keys: F1, F2, F3, F4. They refer to the display line number (display with 4 lines). Inside the APR program, each pushbutton refers to the relative display line, by choosing the described function. With DAP meter present and in working condition (displayed dose), the key F4 allows to print the data concerning the dose released to the patient, on a printer available as accessory.

4.8 Display



Alphanumeric display with four lines of 20 characters for the display of the equipment status, the x-ray parameters and the warning/error messages.

4.9 Light signals

Symbol	Mnemonic	Color	Description
	ON	green	ON: voltage presence.
 Ready	READY	green	ON: ready equipment
 	X-RAY	yellow	ON: x-ray emission



Light signals can't be disabled

4.10 Acoustic signals

Signal	Description
2 BEEP	Signal of storage occurred
3 BEEPS	x-ray emission occurred with success
1 LONG BEEP	Alarm or malfunction signal (1 sec)



The volume of the acoustic signals can't be adjusted

5 MESSAGES

The equipment foresees three types of messages on display:

S = Status of equipment

No influence on the working

W = Warning

Press the key RESET on the keyboard to delete the warning message and go on to work.

F = Error

The equipment must be switched ON again.

A list of errors is created to ease the following work of Service personnel.



The message is displayed in the language used for the equipment configuration.

All warning messages must be reset by the operator through the key RESET near the message.

Status messages

Typ.	Text	Meaning	Intervention
S	READY	The equipment is ready to perform an exposure	
S	WAITING	Preparation phase	Wait for message "READY"
S	MANUAL		
S	DAP READY	Dosimeter ready	-

Warning messages

Text	Text	Meaning	Intervention
W	CLOCK ERR.	System clock error	Press the RESET key to go on
W	INI. APR	APR checksum error	Press the RESET key to go on
W	ERROR IN APR	An APR error is out of scale	Set differently the parameters
W	TUBE SEASONING	After a long idle period (3 months or more) it is necessary to proceed to the X-ray tube seasoning, with the purpose to avoid serious faults	Press the RESET key to go on, call Service for the tube seasoning
W	HOT TUBE	The temperature of the monobloc has reached the max. allowed value	Wait the monobloc cooling
W	EXPIRED TIME	The x-ray handswitch has been pressed at the "1° step" for more than 15 seconds	Release the handswitch and repeat the x-ray
W	MANUAL STOP	The x-ray handswitch has been released before the end of the exposure	Press the RESET key to go on
W	INACTIVE DAP	Dosimeter not connected	-
-	MAX DOSE	The doses counter has reached the max. value that can be displayed.	Press the F1+RESET key to reset the value.
W	DAP ERROR	Dosimeter connected, but in error.	Press the RESET key and call Service.
-	DAP RESET	The sum of the product-area doses	-

has been reset.

Error messages

Typ.	Text	Meaning	Intervention
F	FAULTY POWER	Error on the Charger or Chopper. Energy not available	Switch OFF, wait some minutes, switch ON, if the error appears gain call Service
F	ERROR V3	Absent V3 power supply	Switch OFF, wait some minutes, switch ON, if the error appears gain call Service
F	FILAMENT	Filament current not present	Switch OFF, wait some minutes, switch ON, if the error appears gain call Service
F	ERROR V2	Power supply V2 not present in the circuit of mA and kV set	Switch OFF, wait some minutes, switch ON, if the error appears gain call Service
F	LOCKED STARTER	Error during the start time	Press the RESET key to go on, repeat x-rays
F	LACK OF X-RAY	The kV have not reached 75% of the value set within the first 10mS of exposure or lackage of kV	Press the RESET key to go on, repeat x-rays
F	MAX. TIME	The max. exposure time has been reached.	Press the RESET key to go on, repeat x-rays
F	DATA ERROR	Memory error, data checksum error	Switch the equipment OFF, wait some minutes and then switch it ON again, if the error appears again call Service.
F	INVERTER KV ERROR	During the XR emission the kV are decreased under 75% or increased over 110% of the value set or the high voltage circuit unbalanced during the exposure	Press the RESET key and repeat the exposure
F	INV. OVERLOAD	Power to the inverter out of scale	Press the RESET key and go on
F	INVERTER ERROR	IGBT drivers error	Press the RESET key and go on
F	TUBE CALIB. ERR.	Error of XR tube calibration	Call Service.
F	XR HANDSWITCH ERR.	Faulty x-ray handswitch	Check the integrity of the x-ray handswitch, switch OFF and switch ON the equipment, try again, if the error persists call Service

6 TRANSPORT



Tilting hazard.

Use and transport on inclined floors.

- ▶ Don't use the equipment on floors with an inclination higher than 5°.
- ▶ Don't move the equipment on floors with an inclination higher than 10°.



Danger of damages and injuries during the equipment movement.

The uncontrolled movement of the equipment could cause damages to the operator, patient and personnel in the proximity of it.

- ▶ The equipment must be moved only in the condition called "transportation" and with all the blocks of the movements activated.

6.1 Transport position

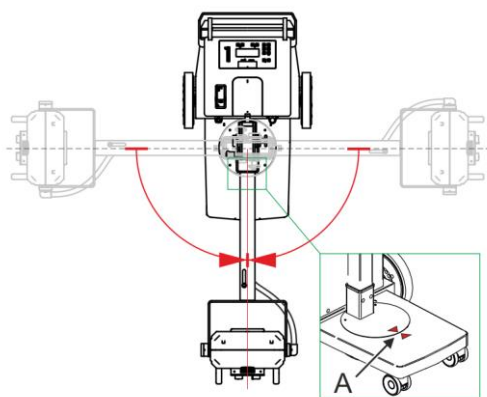

1. Switch the equipment OFF.
2. Unplug from the socket outlet and roll up the cable on the proper cable reel
3. Put the image receptor and the relative cable in the proper casing.

Solo per versione con colonna rotante

4. Move the column in central position. Check that the two arrows (A) on the column base are aligned.

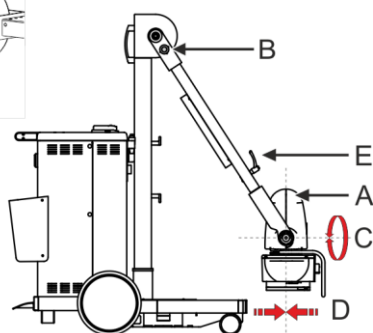
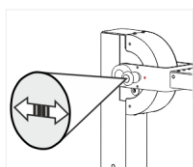

5. Move the monobloc-collimator group (A) DOWN till the safety lock clicks (B).



In order to be sure that the safety lock (B) engages, turn the knob with the arrow towards the red point.

6. Move the monobloc-collimator group (A) in vertical position on both rotation axes (C) (D).
7. Rotate clockwise the monobloc rotation lock handle (E).

6.2 Moving the equipment

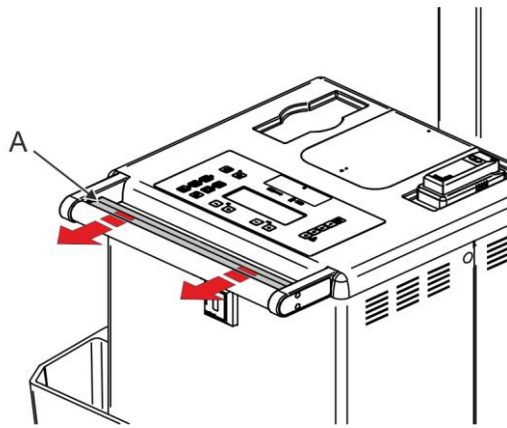

1. For moving the equipment, grip with both hands the transport handle.

Only for rotating column version

Pull the brake lever (A) to unlock the brakes. In order to stop the equipment, release the brake lever.

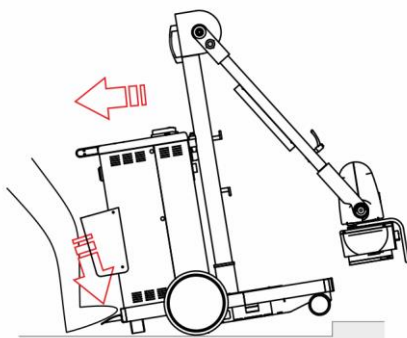

Grip always the transport handle with both hands.

For stopping the equipment, decrease the speed till the equipment is still. Then release the activation bar.

By releasing the brake bar without decreasing the speed, the equipment stops immediately abruptly.

2. In order to overcome obstacles or small gaps, push with the foot on the tilting pedal and, at the same time, pull the handle placed on the column.

6.2.1 Hanger for the leaded apron



Damages and injuries hazard.

The weight of the leaded apron hanging on the monobloc support arm or directly on monobloc, could cause uncontrolled movements of the arm and trouble of monobloc positioning on the patient.

- ▶ Don't hang the leaded apron to the monobloc support arm.
- ▶ Use only the proper hanger.

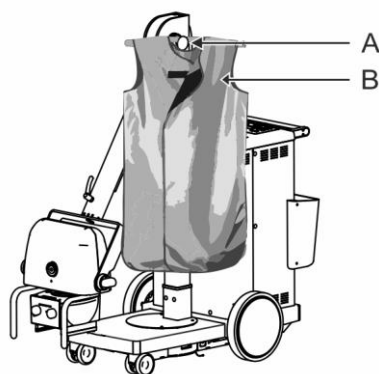

The equipment is provided with a hanger to transport comfortably a leaded apron.

A - Apron hanger

B - Leaded apron

7 FUNCTIONING

7.1 Start up

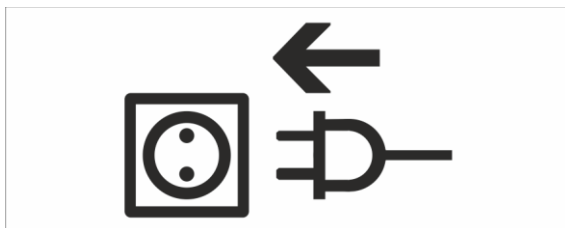

1. Unroll the mains cable from the cable reel and extend it completely.
2. Insert the plug in a standard wall outlet by keeping the cable extended.

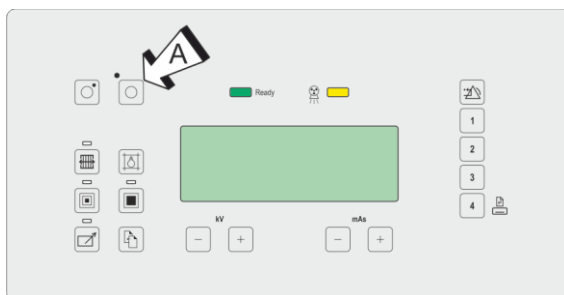

The presence of the mains voltage is indicated by the switching-ON of the green led near the ON push button (A).

If the green led is OFF, check that the lever of the circuit breaker placed on the front part of the equipment is in "I" position.

3. Press the ON push button (A).

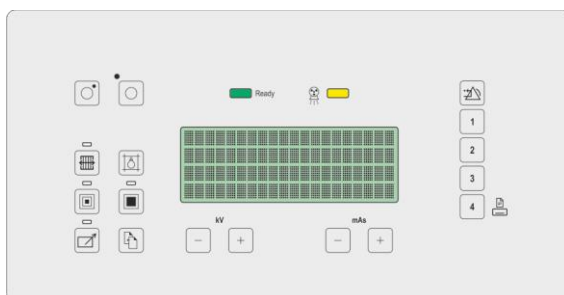

4. At the start up the microprocessor performs a visual check:

- the beeper emits a sound
- in sequence all the display lines light up
- all the keyboard leds light up.

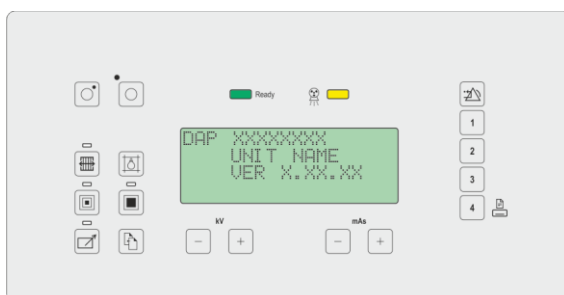

5. At the end of the test, on the display the name of the equipment and the software version appear.

6. If present the DAP meter, the writing "DAP XXXXXXXX" appears.



XXXXXXXX can have the following values:

READY: the reading of the chamber is enabled and it works properly.

ERROR: the reading of the chamber is enabled but the chamber does not work properly, it is not present or it is not connected.

INACTIVE: status displayed after ERROR signal and after pressing RESET key.

In case at the test the DAP meter is accepted, the writing READY appears and the system goes on.

In case it is not accepted, the writing ERROR appears and the sound error alarm is activated .

At this point it is necessary the intervention of the operator; by pressing RESET key it is possible to proceed with the start-up of the equipment by signalling INACTIVE DAP.

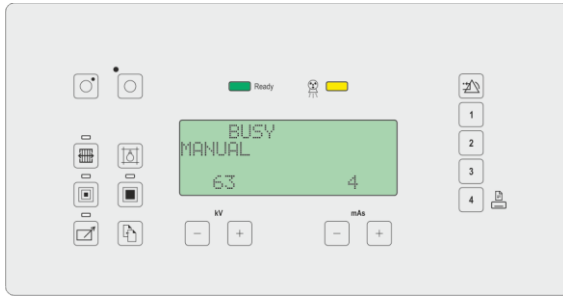

7. Charge phase of the capacitors group. The display indicates "BUSY".



The phase of equipment start-up changes from a few seconds to two minutes, according to the residual charge of the capacitors.

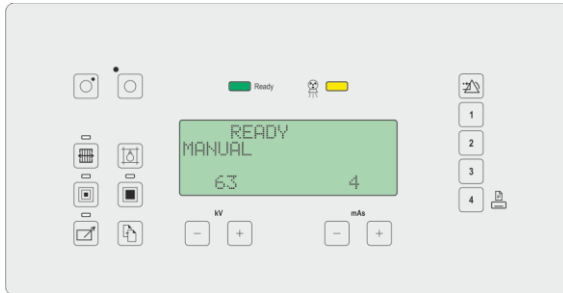

8. The writing "BUSY" is replaced by the writing "READY".



The indicated values are only indicative.

7.2 Positioning

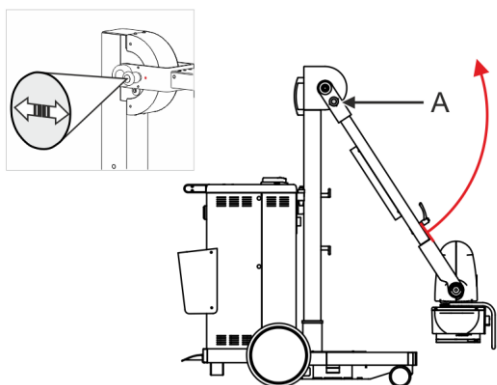

1. Pull and rotate the safety lock (A) so that the arrow is towards the green point direction.
2. Move the monobloc support arm UP.

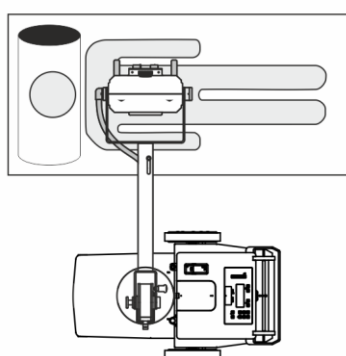

3. Place the monobloc-collimator (A) on the interested part of the patient, if possible in perpendicular position.



In the version with rotating column, this can be rotated $\pm 90^\circ$ to facilitate access in restricted areas.

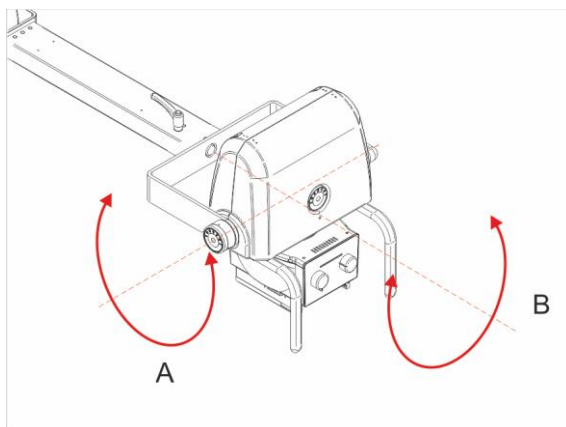

4. The monobloc-collimator group can rotate of $+102^\circ$ and -49° in respect of its axis (A) and, around the arm axis $\pm 180^\circ$ (B),



5. Switch the collimator lamp ON.
6. Collimate the radiation beam to the image receptor dimension or of the examination interest part.
7. Measure the focal distance.

On the front panel of the collimator there are two knobs (A) to adjust the beam amplitude (width and length), the push-button to switch ON the collimator lamp (B) and the tape measure (C) to measure with accuracy the focus-film distance (DFF).

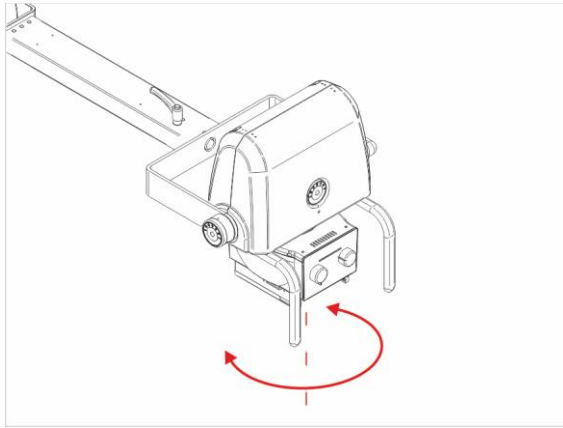

8. If necessary, rotate the collimator.

The collimator can rotate around its axis of $\pm 120^\circ$.

To rotate it is enough to grip it with both hands and rotate in the wished direction.



To the min. inherent filtration of the collimator it is possible to add an additional filtration obtained through a disk moved manually.

On the disk, in addition of a hole for the passage of the x-ray beam without additional filtration there are the following three filters:

“_“ 1mm Al + 0.1mm CU

”_ -“ 1mm Al + 0.2mm CU

“- - -“ 2mm Al

The switching-ON of a yellow LED placed on the front panel of the collimator indicates the insertion of the additional filtration.

7.3 Exposures



The values indicated in the following images are only indicative.



For paediatric use, add a proper filter before performing an exposure.

7.3.1 Free exposure

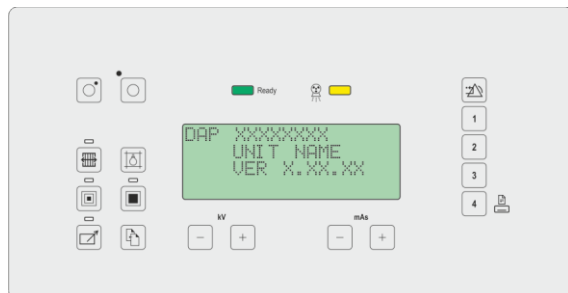

After the initial tests, the display shows the initial screen.

The initial parameters of the equipment are displayed as they have been stored during the configuration.

It is possible to modify manually the x-ray parameters:
kV, mAs, Focus

7.3.2 Exposures in Programmed Anatomic mode (APR)

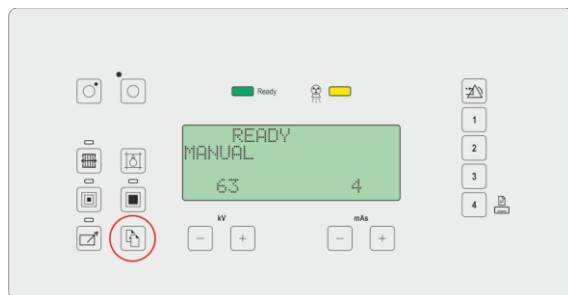

1. Press MENU key to enter APR mode.

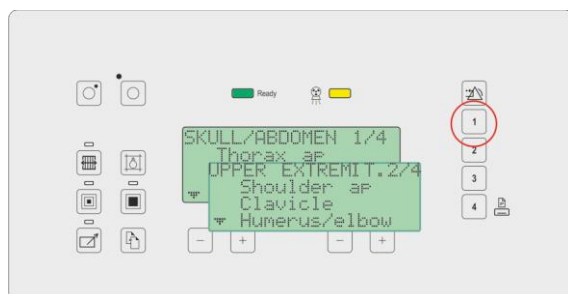

The APR mode is composed by four anatomic groups.

2. Press the F1 function key F1 to scroll inside the list of the examinations groups.

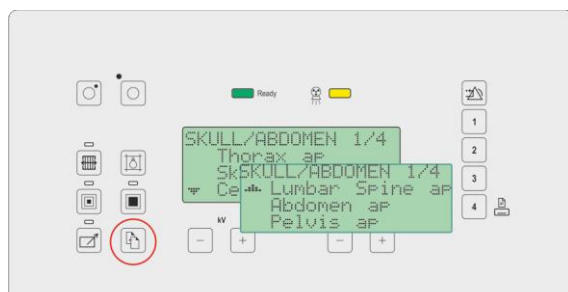

Every group is composed by six APR programs. The list of the six programs covers three pages.

The following or previous page is underlined with the symbol "▼" or "▲".

3. Press MENU key to scroll inside the pages of the chosen group.

4. Press one of the F2 F3 F4 function keys to select the wished APR program.

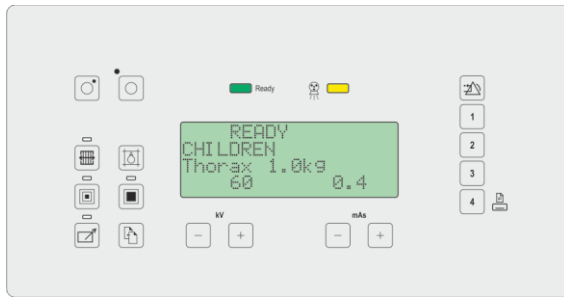

On the display the name of the selected object/organ and the associated exposure parameters (kV mAs focus) appear.

1^ line: reserved to messages

2^ line: selected group

3^ line: name of examination

4^ line: x-ray parameters (kV and mAs)

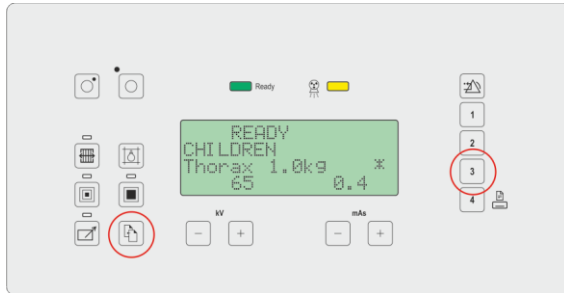

The modification of some x-ray parameters in respect of the stored values is indicated by the asterisk (*) near the program name.

To store the new values it is necessary to press the push button F3 and, by holding it down, press the MENU key.

The occurred storage is indicated by a sound signal and by the asterisk (*).

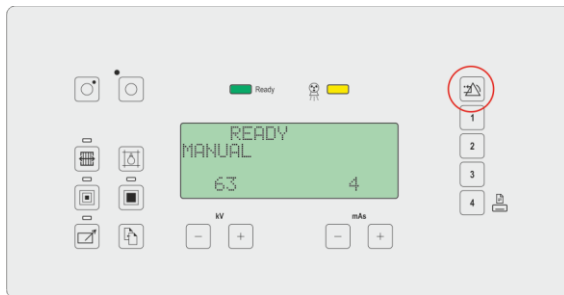

Press the RESET key to return to the free exposure mode.

Press the F2 function key to return to the APR programs list.

7.3.3 APR data table



APR programs suggested and preloaded by the manufacturer on the equipment, only represent recommendations to be applied to the patient in order to optimize the operation and result of the examination.

kV and mAs values set at the factory in APR programs can be modified at any moment by the user. They can be stored only if, during the equipment configuration, this possibility has been set (by authorized personnel only).

In the following table the dose values are expressed in μGym^2 (DAP Dose Area Product), the exposures are set with standard values for clinical investigations on the patient and performed with the x-ray tube with a SID (Source - Image receptor Distance) of 100 cm without grid.

The dose measurement has been performed according to IEC 60601-1-3 § 5.2.4.2 with dosimetric chamber supplied with the equipment and collimator with all shutters opened.

"BODY" folder

Name	Focus	kV	mAs	μGym^2
Thorax AP	LF	110	2	17.83
Abdomen AP	LF	81	16	76.37
Abdomen LAT	LF	90	20	118.94
Thorax LAT	LF	110	4	34.63
Breastbone	SF	85	4	22.84
Ribs	SF	70	6,3	24.12

"CRANIUM/vertebrae" folder

Name	Focus	kV	mAs	μGym^2
Cranium AP	SF	77	10	46.71
Vert. dors. AP	SF	77	20	93.97
Vert. lumb. AP	LF	81	20	104.10
Vert. cervic.	SF	66	8	27.07
Vert. dor. LAT	LF	81	16	76.39
Vert. lumb. LAT	LF	90	20	118.84

"UPPER EXTREMITY" folder

Name	Focus	kV	mAs	μGym^2
Clavicle	SF	66	5	16.81
Humerus	SF	60	3,2	8.56
Elbow	SF	55	4	8.53
Forearm	SF	55	2	4.27
Wrist	SF	50	2	3.25
Hand/Fingers	SF	46	1,6	1.99

"LOWER EXTREMITY" folder

Name	Focus	kV	mAs	μGym^2
Hip/Femur	SF	81	12,5	64.73
Knee	SF	63	5	15.07
Kneecap	SF	63	8	24.18
Leg/Ankle	SF	60	4	10.69
Foot	SF	48	2	2.85
Foot fingers	SF	44	2	2.12

"CHILDREN I" folder

Added Filter 1mmAl + 0,2mmCu (**)

Name	Focus	kV	mAs	μGym^2
Thorax 0,5 kg	SF	60	0,1	0.14
Thorax 1,0 kg	SF	60	0,2	0.24
Thorax 2,0 kg	SF	60	0,32	0.37
Thorax 3,0 kg	SF	62	0,4	0.54
Thorax 4,0 kg	SF	65	0,4	0.63
Thorax 5,0 kg	SF	68	0,4	0.75

"CHILDREN II" folder

Added Filter 1mmAl + 0,2mmCu (**)

Name	Focus	kV	mAs	μGym^2
Thorax 8,0 kg	SF	76	0,4	1.08
Abdomen 4,5 kg	SF	65	2	3.19
Abdomen 8,0 kg	SF	65	3,2	5.13
Thorax 10 kg	SF	76	0,8	2.18
Abdomen 10 kg	SF	70	2	4.16
Abdomen 15 kg	SF	70	4	8.36

(**) The combination of filter 1 mm Al +0,1mm Cu is allowed too.

7.4 Operation mode

The equipment manages two exposure operation modes that can be selected by the operator at any minute:
LOCAL: the exposure is performed with the wire control with extensible cable supplied with the equipment.
REMOTE: the exposure is performed with the infra-red remote control (accessory), if installed.

At the start up the mode is LOCAL.

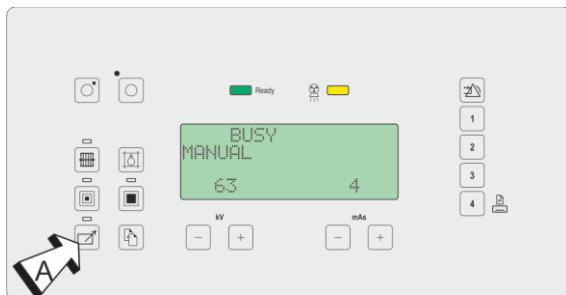

1. Press the key (A) to change exposure operation mode. The led ON near the key indicates the REMOTE mode.



An exposure mode excludes the other one.

LOCAL mode



Ionizing radiations.

The operations described below require the emission of ionizing radiations.

► Take the proper measures to avoid exposing any part of the body to direct or indirect radiations.



Completely extend the extensible cable of the x-ray control and keep at least two meters from the radiation source.



The cable of the x-ray control can be extended without irreversible deformations till 4 mt. Beyond 4 mt the deformation becomes irreversible and the x-ray control must be replaced.

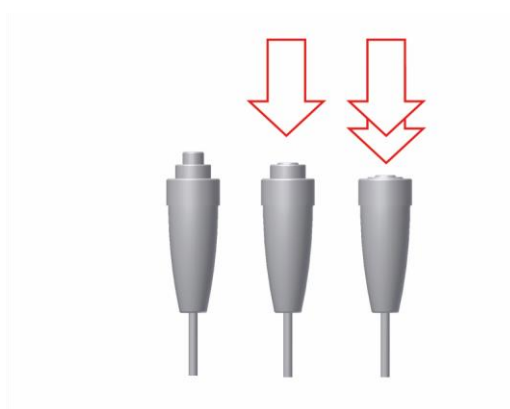

The x-ray emission control consists of a double step push-button:

1° step : preparation

2° step : exposure control

Hold down the x-ray emission control as long as the exposure expires, then release it.

When the exposure has been completed, the equipment emits three beeps as signal.



It is possible to fully press the x-ray emission control ("exp" position) from the beginning. In this case the x-ray exposure will be automatically performed after the preparation.

REMOTE mode (optional)



Ionizing radiations.

The operations described below require the emission of ionizing radiations.

- ▶ Take the proper measures to avoid exposing any part of the body to direct or indirect radiations.



Keep as far as possible from the radiation source.



The infrared remote control works in visual mode up to 10 mt with an operating angle of $>180^\circ$, even through glass and leaded glass.

It doesn't work through doors or walls.

Activation

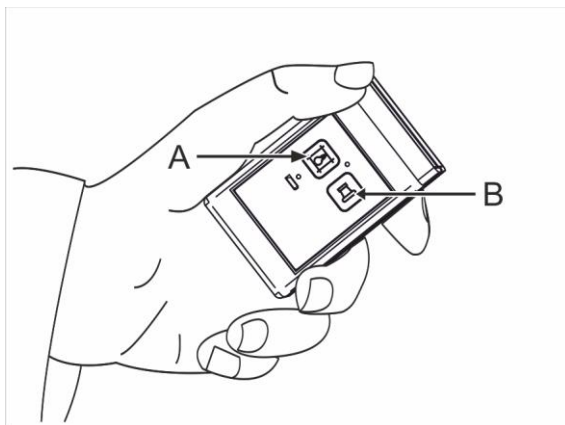

1. Remove the remote control IR from its support base, move away as much as possible from the x-ray source and address the remote control towards the receiver on the equipment.
2. Press the key "LAMP" (A) to turn the collimator lamp ON.
3. Press and release the key "RAD" (B) to start the exposure preparation phase.
4. Press and hold down the key "RAD" to perform the exposure.
5. After performing the exposure, put again the remote control in the support base on the equipment.

Deactivation

The light of the collimator deactivates automatically by pressing the key "RAD" or by pushing the key "LAMP".

The preparation cycle stops automatically and the stand-by condition returns if the exposure is not controlled within 15sec from its activation.

At the end of the exposure the equipment returns in stand-by even if the key "RAD" is held down. In order to perform a new exposure, it is necessary to release the key.

The exposure in progress can be stopped by releasing the key "RAD" ("*dead man*" control).

In case the receiver should lose the received signal because of insufficient intensity or interference of a body or an object that inhibits the IR signal to arrive to the receiver, therefore the active controls are immediately removed. For performing a new control, it is necessary to release the key and then press it again.

Remote anti-loss research

In case the remote control has not been put into its support base for 2 minutes from the last press of a key, an audible signal, a series of two "beeps" every 5 seconds, is emitted.

In order to stop the audible signal, put the remote control again in its support base, or press one of the two keys. This press does not imply any control, in order to perform a control it is necessary to press it twice.

When the remote control is in its support base, it switches OFF and there is no batteries consumption any more. In this condition no control is released by pressing the keys.

Indication of discharged batteries

The indicator of discharged batteries (red LED) flashes with 1 flash per second when the batteries have a limited autonomy (recommended replacement) and with 2 close flashes every second when the batteries are discharged (mandatory replacement).

7.4.1 After the exposure

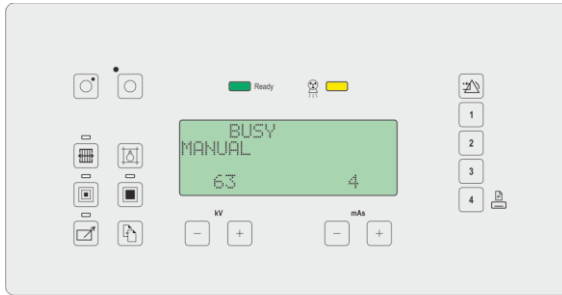

An acoustic signal (three beeps) indicates the correct exposure progress.

The performed exposure time is displayed in ms.

The writing "BUSY" replaces "READY" till the equipment is ready for the following exposure.

The writing "Exposure done" flashes for about 15s between the kV and mAs data.



If the x-ray button is held down at "1" click (preparation phase) for more than fifteen seconds without pressing the "2" click (X-ray releasing phase), the message "OVERTIME" is displayed. Release the pushbutton, press the key RESET and repeat the exposure.



If the x-ray emission control is released before the end of the exposure, the message "X-RAY MANUAL STOP" is displayed and the exposure is interrupted.

The radiological data effectively released are displayed.

Press the key "RESET" and repeat the exposure.

7.5 Optional: radiography with examination table or Potter Bucky grid



In LOCAL mode: fully extend the extensible cable of the x-ray control and stay as far as possible from the radiation source.

In REMOTE mode: stay as far as possible from the radiation source.



The mode "Radiography with examination table or Potter Bucky grid" is active in CR mode or with Digital Imaging System OFF.

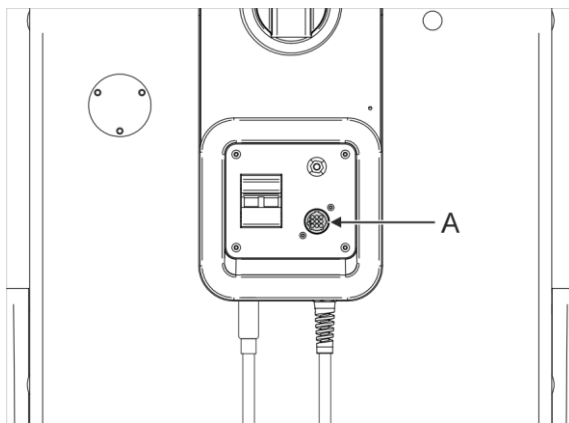

Version with fixed column

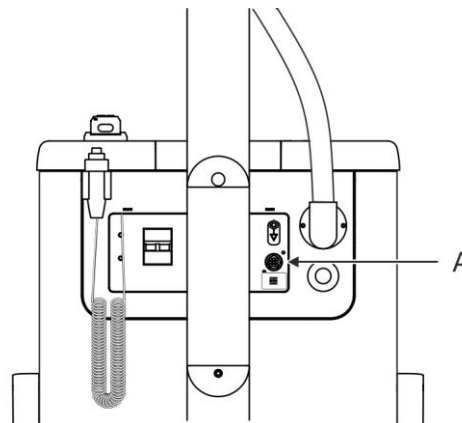

Version with rotating column

1. Place the cassette and the patient according to requirements.
2. Connect the examination table or the Potter Bucky grid to the connector (A) placed on the front part of the equipment.

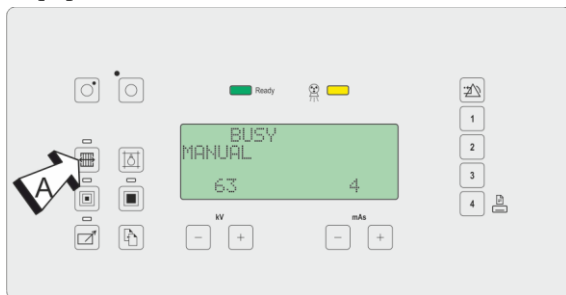

If the connection with the examination table or with the Potter is right, the display shows the relative icon.

3. Press the push-button (A) to activate the Potter Bucky.

4. Place the monobloc and collimator, set the exposure field.
5. Select kV and mAs values in manual or APR mode by selecting the data concerning the exam to be performed.
6. Hold the wired x-ray emission control or the remote control (optional)
7. Go as far as possible from the x-ray source.
8. Perform the exposure. At the end of the exposure the acoustic signal of the equipment emits three beeps.



When the examination table or the Potter Bucky grid have been selected, one of the most frequent difficulties is the "no consent to proceed" of the Potter Bucky grid: in this case check the connection.

7.6 Optional : DAP meter



The installation and maintenance of the DAP meter can be performed only by authorized service personnel.



To correctly determine the dose value to which the patient has been exposed, it is necessary to reset the dose value before starting the exam.

The equipment can be supplied with a ionization chamber dosimeter (dose-area product meter, DAP meter). The DAP meter can be installed during the preparation or in a following phase.

The function of the DAP meter is to measure the dose-area product (μGym^2) that is going out towards the patient:

$$\sum_{i=1}^n \text{dose}_i \cdot \text{area}_i$$

"n" is the number of exposures performed after the last pressing of F5-RESET push-button.

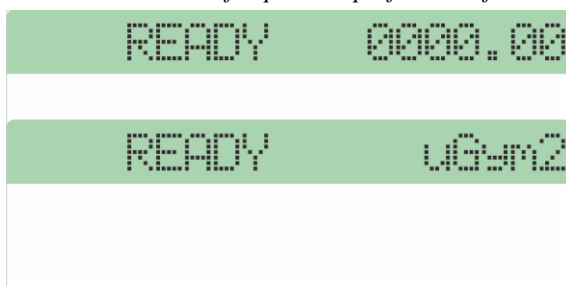

If the DAP meter is installed and worked properly, the first line of the display shows the standard of measurement (μGym^2) and the sum of the measures.

The sum of the measures is the sum of all dose-area products read by the chamber.

The value is reset by pressing the F1+RESET pushbutton.

7.7 Optional: data printing

With installed and working DAP meter, it is possible to print data concerning the dose released to the patient on a dedicated printer, that is available as accessory upon request.

The data are printed on a 54x54mm format self-adhesive label, which can be glued to the examination film.

To print the data of each single exposure, it is necessary to reset the value of the measures sum.

In the printing there are the values concerning:

Data	Description
Name/Id	Patient's name (*)
Day of birth	Patient's date of birth (*)
xxxx.xx cGycm2	Dose released to the patient (0000.00 cGycm2)
Operator	Operator's signature (*)
Date	Date and time of the exam (format dd-mm-yy hh:mm)

(*) data to be entered by hand by the operator

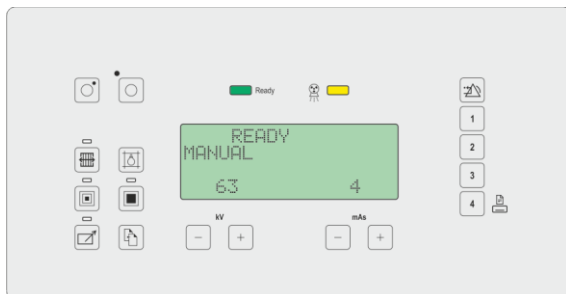

1. Press the function key F4 to print the dose value.



The function for printing the dose value is active only with DAP meter installed and in working condition.

Replacement of the paper roll

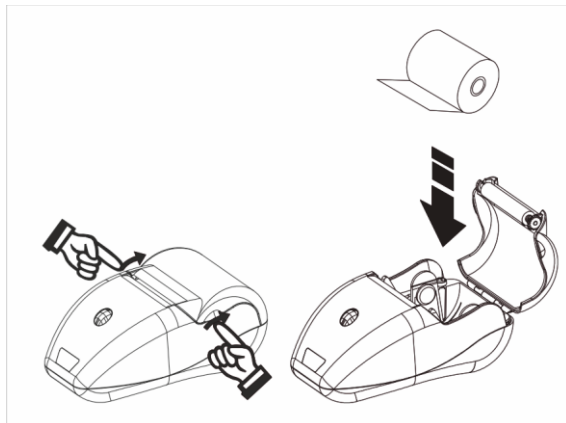

1. Open printer cover, relying on the side slabs of the cover and place the roll paper by respecting the direction of the paper rotation.

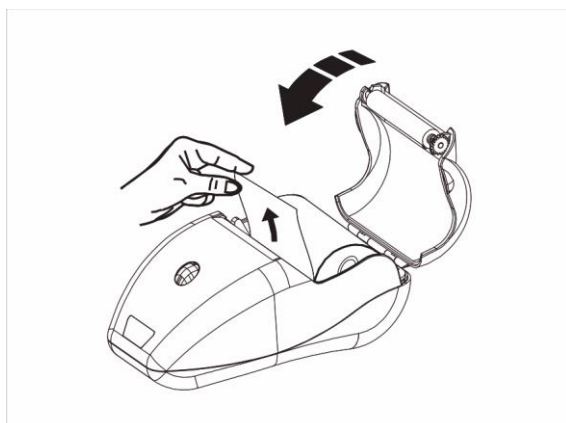

2. Pull upwards the paper and close the cover.
 3. Tear off the paper. The printer is ready.
- The right printing position is automatically determined by the printer.

7.8 Use end



Potential risks

Damages to the connectors and equipment.

- ▶ Grip the plug to extract the connector
- ▶ Don't extract the plugs from the outlets by pulling the cable.
- ▶ Handle the connectors with care.

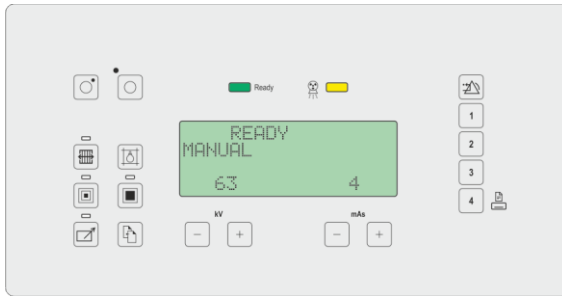

1. Place the equipment in transport position.
2. Switch the equipment OFF.

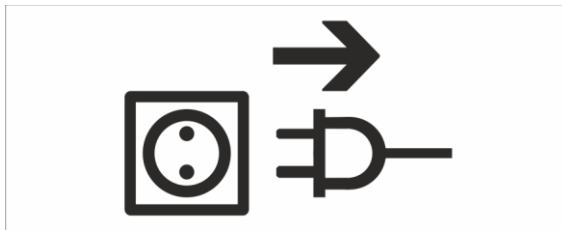

1. Unplug the power supply cable.
2. Wind the cable on its reel.
3. Move the equipment in a suitable place for the parking.



After every use, clean the equipment from possible traces of dirt, body fluids and other radio opaque substances, by following the instructions indicated in the chapter about cleaning.

8 TECHNICAL SPECIFICATIONS

8.1 Electrical data

Description	Data
Power supply	115 ÷ 230Vac ±10%, standard monophase with ground conductor. Automatic setting of the equipment according to mains voltage
Frequency	50/60 Hz ± 5 Hz
Absorbed current	10 A
Line compensation	Automatic
Line resistance	<1 Ω @ 115/230Vac
Standard outlet	16 A @ 230Vac
Power supply cable	8 m
Insulation class	Class I with applied parts type B
Use conditions	Continuous working with intermittent load
Classification according to the liquids seepage	IPx0
Safety in presence of anaesthetic inflammable gases	The equipment is not type AP or APG

8.2 Environmental conditions

Environmental Factor	In normal use	Warehouse and transport
Temperature	from 10 °C to 40 °C	from -25°C to 70°C
Relative humidity	from 30 % to 75 % non- condensing	from 10% to 90% non-condensing
Pressure	from 700 hPa to 1060 hPa	from 500 hPa to 1060 hPa

8.3 Total filtration of the equipment

Description	Data
Monobloc	1,1 mmAl @75kV
Additional fixed filter	0
Collimator	2 mmAl @75kV
Total filtration of monobloc group	3.1 mmAL @75kV
Additional filtration of DAPMeter	0.3 mmAl @75kV
Total filtration	3.4 mmAl @75kV

8.4 Mechanical data

Fixed column version

Description	Data	
Width (in transport position)	618 mm	(24.33 in)
Length (in transport position)	1366 mm	(53.78 in)
Height (in transport position)	1444 mm	(56.85 in)
Height of the transport handle	949 mm	(37.36 in)

Description	Data	
Focus-floor distance (Z-axis)	417 mm ÷ 2092 mm	(16.42 ÷ 82.36 in)
Max. height	2333 mm	(91.85 in)
Rotation of the monobloc around the arm axis (α swivel)	$\pm 180^\circ$	
Rotation of the monobloc around its axis (γ swivel)	151°	$102^\circ \div 49^\circ$ con braccio in posizione orizzontale
Movement	Manual with parking brake. Pedal for the obstacles overcoming.	
Rear Wheels	250x50 mm	(9.84x1.97 in)
Front Wheels (swiveling double wheel)	65x55 mm	(2.56x2.17 in)

Description	Data
Weight	170 kg.

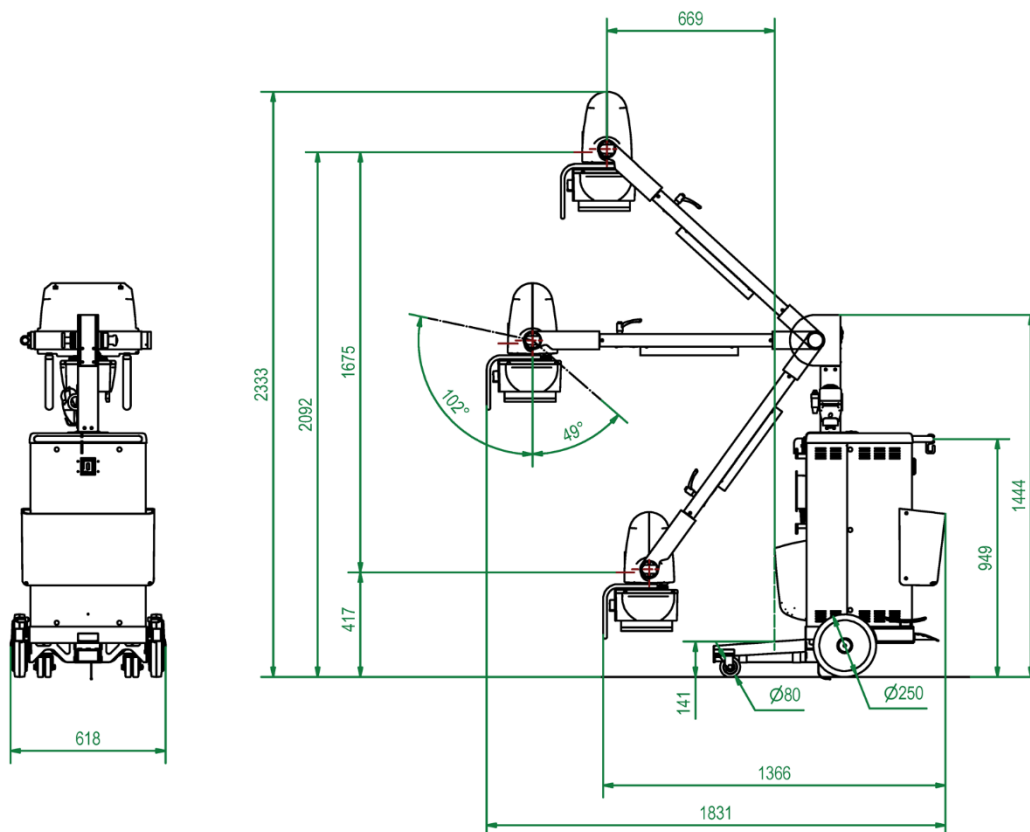

All dimensions are in mm. Linear tolerances ± 5 mm, angular $\pm 1^\circ$.

Rotating column version

Description	Data	
Width (in transport position)	700 mm	(27,56 in.)
Length (in transport position)	1489 mm	(58,62 in.)
Height (in transport position)	1504 mm	(59,21 in.)
Transport handle height	932 mm	(36,69 in.)

Description	Data	
Focus-floor distance (Z-axis)	444 ÷ 2153 mm	(17,48 ÷ 84,76 in.)
Max. height	2393 mm	(94,21 in)
Max. height of the front unit leg	164 mm	(6,46 in)
Max. lateral extension of the arm	747 mm	(29,41 in)
Rotation of the arm around the axis Y (β -swivel)	$\pm 90^\circ$	
Rotation of the monobloc around the arm axis (α swivel)	$\pm 180^\circ$	
Rotation of the monobloc around its axis (γ swivel)	151°	(+102° ÷ -49° with arm in horizontal position)
Movement	Manual with dead man parking brake. Handle (if present) and pedal for the obstacles overcoming.	
Rear Wheels	300x45 mm	(11,81x1,77 in)
Front Wheels (swiveling double wheel)	100x20 mm	(3,94x0,79 in)

Description	Data	
Cassette holder	5 cassettes format 35 x 43 cm (13,78 x 16,93 in.)	
Weight	240 kg (529,11 lb)	

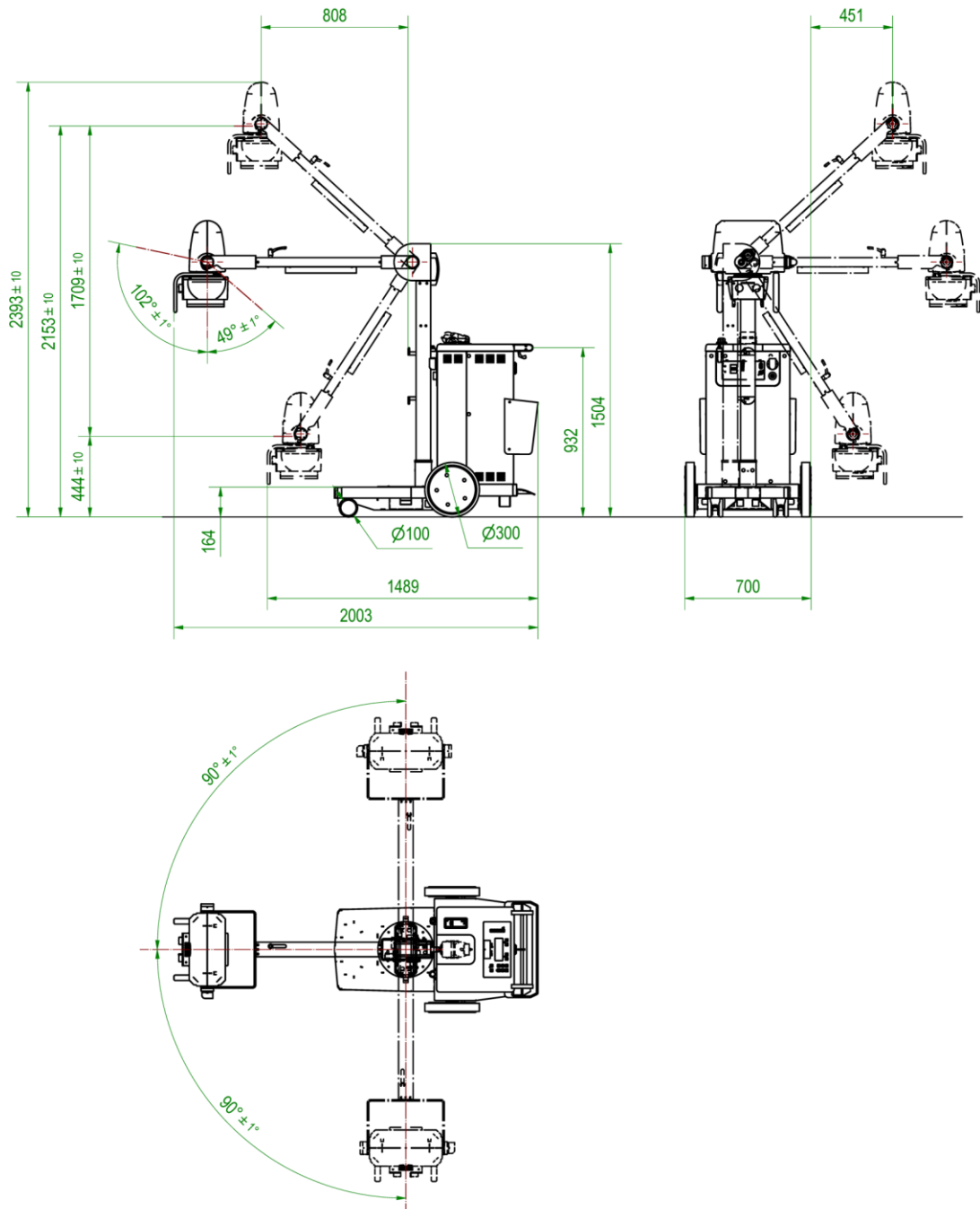

All dimensions are in mm. Linear tolerances ± 5 mm, angular $\pm 1^\circ$.

8.5 Operation data

Description	Data
User interface	Keyboard with alphanumeric LCD display 4 lines x 20 characters for all operative parameters and messages of possible anomalous conditions
	Service program for the management of the errors and the faults
Available languages	Italian, English, French, German, Spanish, Portuguese
X-ray handswitch	Local pushbutton control with extensible cable. Remote control without wires (optional)
Safeties	Breaker circuit for mains overloads Filament current Monobloc temperature Overload Max kV or HV fault Check of the stored data Microcontroller auto test
Programmed Anatomic Mode (APR)	Storage of 36 exams (6 anatomical groups, each one of 6 examinations)
Use coefficient (duty cycle)	Ton:Toff = 1:40 Example 1: Ton = 0,002s - Toff = 0,08s Example 2: Ton = 5s Toff = 200s

8.6 Radiological data

Description	Data
Nominal power (IEC 60601-1)	32kW @100kV, 320mA, 100ms
kV values	40 ÷ 125kV at steps of 1kV
kV accuracy	±5% (IEC 60601-2-54)
mA values @115/230Vac	50 ÷ 400 mA
mA accuracy @115/230Vac	±10% (IEC 60601-2-54)
mAs values @115/230Vac	0,1 ÷ 220 mAs
mAs accuracy	±10% (IEC 60601-2-54)
Exposure times @115/230Vac	0,001 ÷ 2,2 s according to mAs
Time accuracy	±10% (IEC 60601-2-54)



In DR the mAs and the exposure times are limited respectively at 110 mAs and 1s by the FPD panel features.

8.6.1 kV-mAs relationship

from kV	to kV	mAs
---	40	0.1 ÷ 220
41	45	0.1 ÷ 200
46	52	0.1 ÷ 180
53	62	0.1 ÷ 160
63	72	0.1 ÷ 140
73	92	0.1 ÷ 110
93	112	0.1 ÷ 100
113	125	0.1 ÷ 90

8.7 X-ray group

8.7.1 Monobloc

Rotating anode monobloc model MHF2030

HV generator	
Thermo-tinned structure	
Max. power (100 kV - 320 mA)	32 kW
Max. voltage to the tube	125 kV
Max. current to the tube	450 mA
Ripple to the max. power	< 1%
Rise time to the max. power	< 2 ms

Monobloc performance	
According to the load curves of the x-ray tube	

Housing description	
Min. inherent filtration @75 kV	1,1 mmAl
Dimensions (L x P x H)	325 x 145 x 245 mm
Weight	18,5 kg \pm 0,2 kg

Thermal features	
Thermal capacity	600 kJ (810 kWh)
Thermal safety	60 °C \pm 5° C
Thermal switch	normally closed
Capacity of the expansion tank	0,20 dm ³
Continuous thermal dissipation	60 W
Max. housing temperature	60 °C

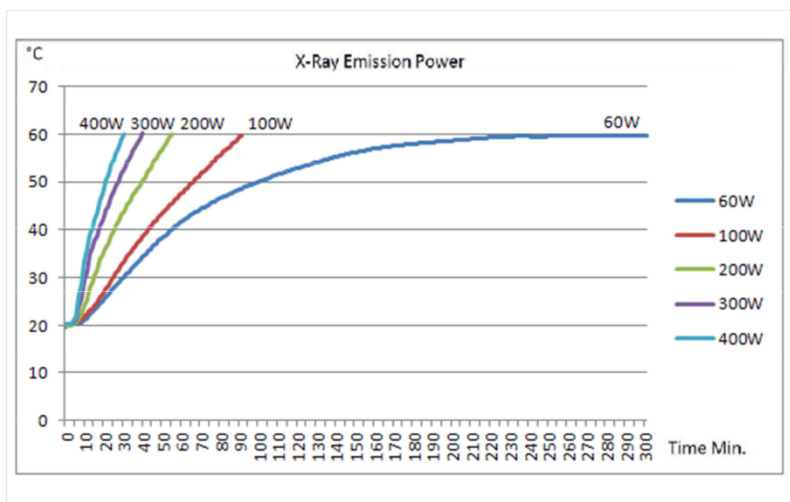

Heating curves (60W, 100W, 200W, 300W, 400W).

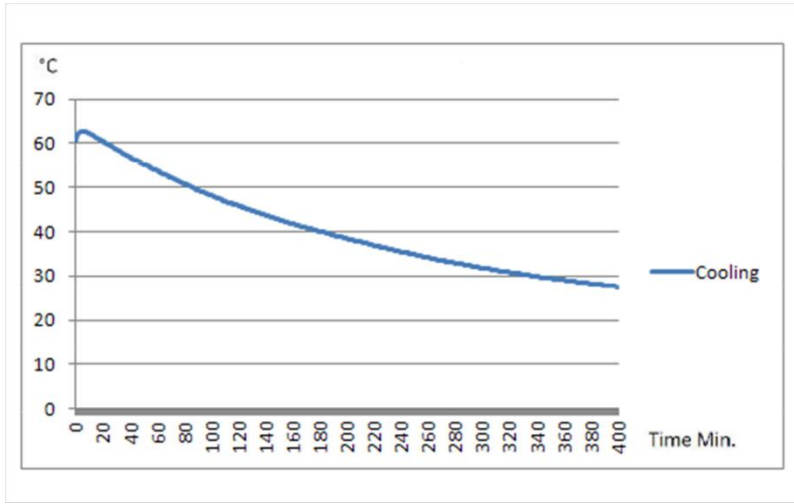

Cooling curve.

8.7.2 X-ray tube

Rotating anode x-ray insert model X22 0.6/1.3

Description	Data
X-ray tube	X22
Rotation speed	3000 min ⁻¹
Nominal High voltage	130 kVp
Nominal focus dim. (IEC 60336)	0,6 mm small focus 1,3 mm large focus
Nominal anodic power (IEC 60613)	11 kW small focus 32 kW large focus
Anodic material	RTM
Anodic diameter	64 mm (2,52in.)
Anodic angle	15°
Thermal capacity of the anode	80 kJ (108kHU)
Max continuous anode dissipation	300 W
Min. inherent filtration (IEC 522)	0,7 mmAl eq.
Tube material	glass

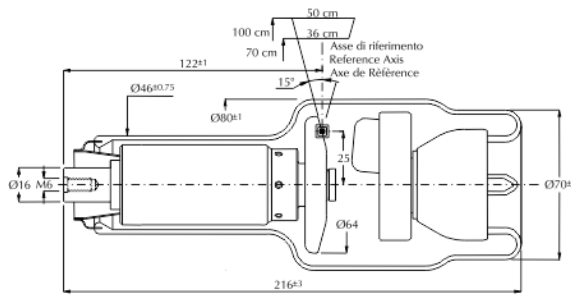

Curve di riscaldamento e raffreddamento dell'anodo
Anode heating and cooling curves
Courbes d'échauffement et de refroidissement de l'anode

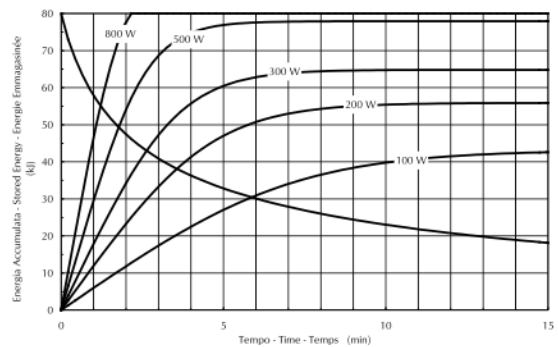

CURVE DI CARICO SINGOLO - SINGLE LOAD RATING - ABAQUE DE CHARGE UNIQUE
■ 0.6 - 3 - 3000 mirf

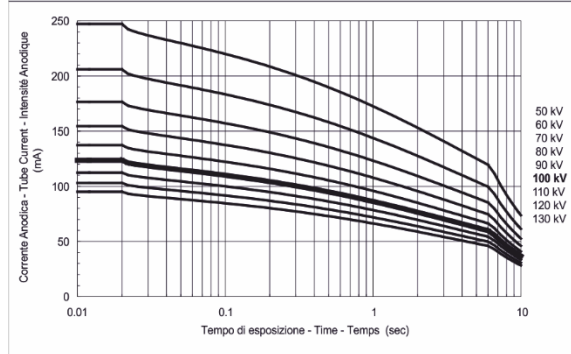

CURVE DI CARICO SINGOLO - SINGLE LOAD RATING - ABAQUE DE CHARGE UNIQUE
■ 1.3 - 3 - 3000 mirf

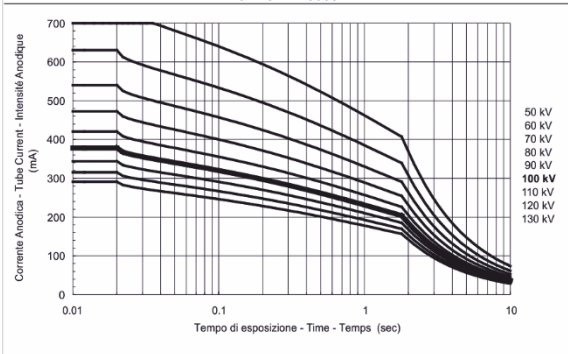

8.8 Collimator

Description	Data
Model	R108 F
Collimation	Manual with internal light source, multilayer, squared field.
Assembly plan from focus	80 mm (3.14")
Coverage of the field at 100cm FFD (SID)	min 0 x 0 cm, max 43 x 43 cm
Lighting source	Clusters of high-brightness LED power.
Lamp lighting time	30 s.
Light intensity (IEC 60601-2-54)	> 160 lux
Minimum contrast ratio (IEC 60601-2-54)	4:1
Focal distance measurement	Retractable tape measure (max extension 3 mt)
Inherent filtration	2 mm equivalent Al/75kV
Additional filtration	Manual section 0 mm Al 1 mm Al + 0,1 mm Cu 1 mm Al + 0,2 mm Cu 2 mm Al
Rotation	$\pm 120^\circ$
Weight	5,5 Kg
Laser	Laser field to determine the focal distance at 1 m

8.9 Optional: Dose Meter

Description	Data
Model	Diamentor CI-P
Type	Device for the area-dose product measurement in x-ray diagnostics according to IEC 60580 standard.
Principle of measurement	Radiation measure with ionization chamber
Measured quantity	Area-dose product
Digital resolution	0,01 μGym^2
Max linearity error	< 2.5%
Nominal range of dose-area product rate	(0,01 ÷ 2500) $\mu\text{Gym}^2 / \text{s}$
Equivalent filtration of the chamber @75kV	0.3 mm Al
Max measurement field	118 x 118mm
Dimensions (W x D x H)	152 x 234 x 23 mm
Weight	455g

8.9.1 Thermal Dose Meter Printer

Description	Data
Type	Movable printer
Model	Custom Print's
Printing method	Thermal printing line
Resolution	203 dpi
Printing speed	50mm/sec*
Paper width (mm)	58 mm
Roll dimensions (mm)	57.5 \pm 1
Print area	48 mm
Interface	RS-232
Power Supply	9/50 Vdc / 0,6 A
Operating temperature	0 \pm 50 $^{\circ}\text{C}$
Humidity storage	10 \pm 85 %, there must be no condensation
Dimensions (WxDxH)	146 x 88 x 65 mm
Weight	340 gr
Safety	EN60950

* it depends on the printing typology and the environment temperature

8.10 Optional: Remote exposures control

Description	Data
Type	Infrared x-ray control device (IR)

Transmitter

Description	Data
Construction	ABS case with matt surfaces Durable fireproof, high resistance to bad use or falls, resistance to water, oils, organic acids and alcohol
Technology	Infrared light (940 nm) with carrier 38kHz. It operates through glass or leaded glass. Don't operate through doors or walls.
Identification signature	Controls with proprietary safety coding at 11 bit - non standard Non compatible with commercial receivers
Power supply	2 alkaline "AA" batteries (LR6) - 1,5 V / 2500mAh. Autonomy > 25.000 exposures.
Operative distance	10 mt (33 feet)
Operative angle	>180°
Remote anti-loss research	Repetition of a series of beeps if the transmitter, after the use, has not been put again for two minutes into its support base.
Light indicators	Yellow LED indicates that the transmission is active Red LED indicates the batteries status: - 1 flash/sec -> recommended replacement - 2 flash/sec necessary replacement

Receptor and Decoder

Description	Data
Construction	Plexiglass®
Power supply	12... 24 Vdc - 50mA
Consumption	1.2W
Identification signature	Controls with proprietary safety coding at 11 bit - non standard Non compatible with commercial transmitters
Commands towards generator	Power supply voltage Vcc – 1V (11 ... 23Vdc) 100mA max per channel

9 ABBREVIATIONS LIST

AP	Equipment or part of it, protected by the ignition of a mix of inflammable anaesthetic with air
APG	Equipment or part of it, designed to avoid any flames in a mix of inflammable anaesthetic with oxygen and nitrous oxide.
APR	Programmed anatomic radiography
CR	Computer Radiography - Displaying system of the primary radiological image based on a phosphors detector
DAP	Dose-area product
DIS	Digital images acquisition system
EMC	Electromagnetic compatibility
ESD	Electrostatic discharge
IP	Protection degree of the electric and electronic devices housings against the penetration of external agent both solid or liquid.
LED	Light-emitting diode
LF	Large focus
PCB	Printed Circuit Board – printed circuit for electronic board.
RF	Radiofrequency
SF	Small focus
SID / DF	Focus-image receptor distance
WEEE	Electric and electronic equipments waste

10 CONFIGURATION AND ACCESSORIES

Description	
X-ray handswitchl with extensible cable	Standard
Apron hanger	Standard
Interface for examination table or Potter Bucky	Standard
DAP meter with ionization chamber	Optional
X-ray emission remote control	Optional
Double laser line on collimator for the definition of the reference distance at 1mt	Standard

Description	
DAP Printer	Optional

Page intentionally left blank

11 DOCUMENT STATUS

Rev.	Date	Description
0	08/2022	Issue of document for adaptation of the new EU regulation 2017/745
0.1	04/2023	Radiological data updating