

# DR Full Leg Full Spine Mobile System

---

## User Manual

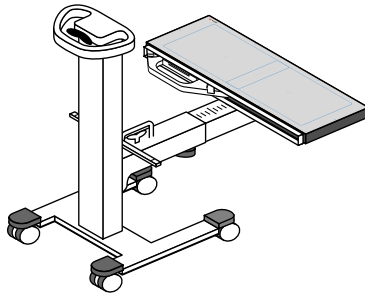

# Contents

|   |    |
|---|----|
| Legal Notice .....  | 4  |
| Introduction to this Manual .....   | 5  |
| Scope of this Manual .....  | 6  |
| About the safety notices in this document .....   | 7  |
| Disclaimer .....  | 8  |
| Introduction to the Full Leg Full Spine application .....   | 9  |
| Intended Use .....  | 10 |
| Intended User .....   | 10 |
| Configuration .....   | 11 |
| Compliance .....  | 13 |
| General .....   | 13 |
| System Documentation .....  | 14 |
| Mobile FLFS detector slot .....   | 14 |
| Installation .....  | 15 |
| Accuracy of Measurements .....  | 16 |
| Cleaning and Disinfecting .....   | 17 |
| Cleaning .....  | 18 |
| Disinfecting .....  | 19 |
| Maintenance .....   | 20 |
| Safety Directions .....   | 21 |
| Basic Workflow .....  | 23 |
| Retrieve the patient info .....   | 24 |
| Select the exposure .....   | 24 |
| Prepare the examination .....   | 24 |
| Prepare the Full Leg Full Spine configuration .....   | 25 |
| Check the exposure settings .....   | 28 |
| Execute the exposures .....   | 29 |
| Perform a quality control .....   | 31 |
| Finalize the examination .....  | 34 |
| Advanced Operation .....  | 35 |
| Manually adjusting a DR Full Leg Full Spine image .....   | 36 |
| To rotate all partial images .....  | 37 |
| To stitch a set of partial images .....   | 38 |
| To align the partial images based on their<br>projection on the stitching grid .....                  | 39 |
| To align the partial images based on the analysis<br>of the anatomical information in the image ..... | 40 |
| To manually align two partial images .....  | 41 |
| To turn the black borders or cropping on or off .....   | 43 |
| To save the stitched image .....  | 44 |
| Rejecting a DR Full Leg Full Spine image .....  | 44 |
| Making measurements .....   | 45 |

|  |    |
|--|----|
| Problem solving .....                          | 47 |
| Anatomical stitching is not optimal .....      | 48 |
| Stitching fails .....                          | 49 |
| Technical Data .....                           | 50 |
| Mobile FLFS detector slot technical data ..... | 50 |

# Legal Notice

---



2862

 Agfa NV, Septestraat 27, 2640 Mortsel - Belgium

For more information on Agfa products, please visit [medimg.agfa.com](http://medimg.agfa.com).

Agfa and the Agfa rhombus are trademarks of Agfa-Gevaert N.V., Belgium or its affiliates. DX-D is a trademark of Agfa NV, Belgium or one of its affiliates. All other trademarks are held by their respective owners and are used in an editorial fashion with no intention of infringement.

Agfa NV makes no warranties or representation, expressed or implied, with respect to the accuracy, completeness or usefulness of the information contained in this document and specifically disclaims warranties of suitability for any particular purpose. Products and services may not be available for your local area. Please contact your local sales representative for availability information. Agfa NV diligently strives to provide as accurate information as possible, but shall not be responsible for any typographical error. Agfa NV shall under no circumstances be liable for any damage arising from the use or inability to use any information, apparatus, method or process disclosed in this document. Agfa NV reserves the right to make changes to this document without prior notice. The original version of this document is in English.

Copyright 2022 Agfa NV

All rights reserved.

Published by Agfa NV

2640 Mortsel - Belgium.

No part of this document may be reproduced, copied, adapted or transmitted in any form or by any means without the written permission of Agfa NV

# Introduction to this Manual

---

## Topics:

- *Scope of this Manual*
- *About the safety notices in this document*
- *Disclaimer*

## **Scope of this Manual**

---

This manual contains information for the safe and effective operation of the DR Full Leg Full Spine Mobile System and the following accessories:

- Mobile Full Leg Full Spine detector slot

## About the safety notices in this document

---

The following samples show how warnings, cautions, instructions and notes appear in this document. The text explains their intended use.

**DANGER:**

A danger safety notice indicates a hazardous situation of direct, immediate danger for a potential serious injury to a user, service engineer, patient or any other person.

**WARNING:**

A warning safety notice indicates a hazardous situation which can lead to a potential serious injury to a user, service engineer, patient or any other person.

**CAUTION:**

A caution safety notice indicates a hazardous situation which can lead to a potential minor injury to a user, service engineer, patient or any other person.



An instruction is a direction which, if it is not followed, can cause damage to the equipment described in this manual or any other equipment or goods and can cause environmental pollution.



A prohibition is a direction which, if it is not followed, can cause damage to the equipment described in this manual or any other equipment or goods and can cause environmental pollution.



*Note: Notes provide advice and highlight unusual points. A note is not intended as an instruction.*

## Disclaimer

---

Agfa assumes no liability for use of this document if any unauthorized changes to the content or format have been made.

Every care has been taken to ensure the accuracy of the information in this document. However, Agfa assumes no responsibility or liability for errors, inaccuracies or omissions that may appear in this document. To improve reliability, function or design Agfa reserves the right to change the product without further notice. This manual is provided without warranty of any kind, implied or expressed, including, but not limited to, the implied warranties of merchantability and fitness for a particular purpose.



*Note: In the United States, Federal law restricts this device on order of a physician for prescription use only.*

# Introduction to the Full Leg Full Spine application

---

## Topics:

- *Intended Use*
- *Intended User*
- *Configuration*
- *Compliance*
- *System Documentation*
- *Installation*
- *Accuracy of Measurements*
- *Cleaning and Disinfecting*
- *Maintenance*
- *Safety Directions*

## **Intended Use**

---

The DR Full Leg Full Spine Mobile System will be used in a radiological environment by qualified staff to read-out, process and route static X-ray radiographic images.

The system is intended to support acquisition of FLFS images using a mobile X-ray system.

## **Intended User**

---

This manual is written for trained users of Agfa products and trained clinical personnel. Users are considered as the persons who actually handle the equipment as well as the persons having authority over the equipment. Before attempting to work with this equipment, the user must read, understand, note and strictly observe all warnings, cautions and safety markings on the equipment.

## Configuration

The DR Full Leg Full Spine mobile system consists of following components:

- Mobile X-Ray system
- DR Detector attached to a handle unit

The size of the detector is equivalent to 14x17 inch (43x35 cm).

- Mobile FLFS detector slot

The patient is positioned on an X-ray transparent carrier that leaves sufficient room above and below for positioning the components of the DR Full Leg Full Spine mobile system.

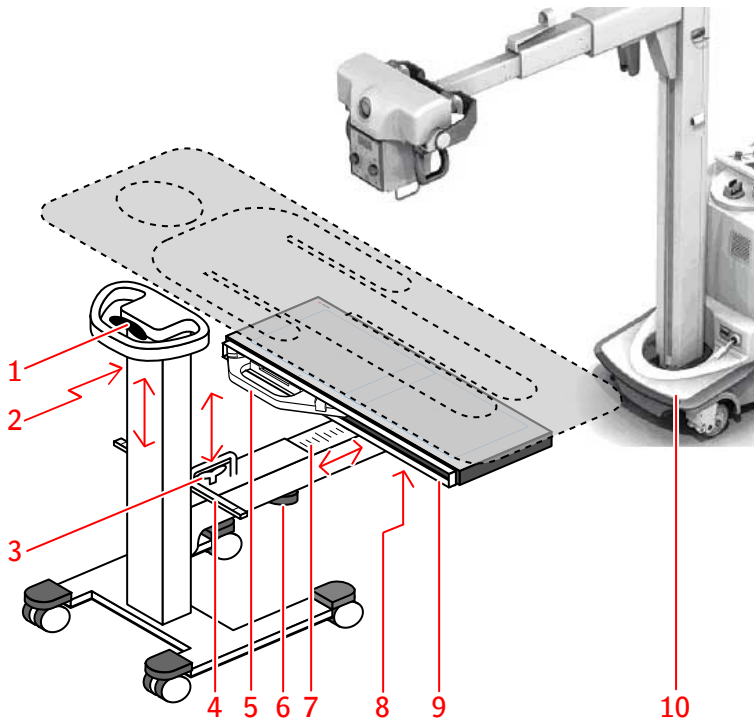

1. Pull handle for adjusting the height of the vertical column
2. Tape measure for measuring the relative position of the region of interest
3. Pull handle for adjusting the height of the horizontal arm
4. Rod with indicators to read out the SID and to align the X-ray tube to the center of the DR detector, using the collimator double laser light
5. DR Detector with handle unit
6. Knob for releasing the telescopic extension of the horizontal arm
7. Ruler for measuring the relative position of the mobile FLFS detector slot when extending the telescopic arm

- 8. Knob for releasing the tilting mechanism
- 9. Slot for inserting the DR detector
- 10. Mobile X-ray system

**Figure 1: Mobile FLFS detector slot**

# Compliance

---

## General

- The product has been designed in accordance with Regulation (EU) 2017/745 on medical devices (MDR)

## System Documentation

---

The documentation shall be kept with the system for easy reference. The most extensive configuration is described within this manual, including the maximum number of options and accessories. Not every function, option or accessory described may have been purchased or licensed on a particular piece of equipment.

Refer to the System User Documentation before using the Full Leg Full Spine application:

- User Manual of the DR system and related user documentation
- NX User Manual

The most recent version of this document is available on <http://www.agfahealthcare.com/global/en/library/index.jsp>

### Mobile FLFS detector slot

The Mobile FLFS detector slot is delivered with its own user documentation.

## **Installation**

---

Installation and configuration is performed by an Agfa trained and authorized service engineer. Contact your local support organization for more information.

## Accuracy of Measurements

---

Distance measurements on DR Full Leg Full Spine images in NX are displayed with a resolution of one or more decimal places (such as 0.01 cm). You should be aware that the real measurement accuracy is generally considerably lower for a number of different reasons, many beyond the control of the product.

Distance measurements can be calibrated based on the Estimated Radiographic Magnification Factor.

The measurement accuracy is limited by at least four factors:

- The quality and nature of the input data, including but not limited to the accuracy of the calibration values.
- The user's ability to select appropriate points on the screen.
- The transformations inherent in generating images on a finite pixel display.
- The stability of the patient during the examination.

It is the user's responsibility to understand these limitations and to use the measurement tools responsibly.

For the distance measurements on DR Full Leg Full Spine images, the accuracy is 0.2 cm. The accuracy applies to the difference between the size of the projection of the object on the stitching grid and that measured with the product, on these conditions:

- The image is stitched based on the grid markers.
- The object has not moved during the examination.
- No pressure is applied on the stitching grid, causing it to bend.



**WARNING:**

If the patient leans against the stitching grid, the bending of the grid will decrease the accuracy of length measurements.



**WARNING:**

The system cannot predict the impact of patient movement or of inaccurate input data on the accuracy of a measurement done on anatomical parts.



The user is responsible for observation of the movement of the patient during the examination. Such movement influences the accuracy of measurements when using the anatomical stitching. Perform the quality control of stitched image as described in the basic workflow and take into account vertical and horizontal correction in stitching zones when performing measurements.

### Related Links

[Making measurements](#) on page 45

[Perform a quality control](#) on page 31

## Cleaning and Disinfecting

---

All appropriate policies and procedures should be followed to avoid contamination of the user/staff, patients and other equipment. All necessary precautions shall be taken to avoid patient contact or contact with potential sources of contamination. Cleaning agents and disinfectants should only be used by trained people with required knowledge to complete the cleaning and disinfecting task in a safe and effective way. The selection of the appropriate, legally marketed disinfecting agents and procedures is the responsibility of the hospital. The selection shall be performed according, amongst others, to the severity of the contamination.

### Topics:

- *Cleaning*
- *Disinfecting*

## Cleaning

To clean the exterior of the equipment:

Wipe the exterior of the device with a clean, soft, damp cloth. Use a mild soap or detergent if required. Do not use any corrosive, dissolving or abrasive cleaning or polishing agents. Make sure no liquid gets in the device.



**CAUTION:**

Clean the equipment with only a little moisture.

Using unsuitable cleaning agents or methods can damage the property when surface becomes dull and brittle (e.g. alcohol-containing agents).

## Disinfecting



**WARNING:**

To disinfect the device, use only disinfectants and disinfection methods that are approved by Agfa and that correspond to the national regulation and guidelines as well as explosion protection.

If you plan to use other disinfectants, approval of Agfa is needed before use, as most disinfectants can damage the device. UV disinfection is also not allowed.

Perform the procedure following the instructions for use, the disposal instructions and the safety instructions of the selected disinfectants and tools and of the hospital.

Items contaminated with blood or body fluids, which may contain blood-borne pathogens, should be cleaned and then receive intermediate level disinfection with a product having an EPA-registered claim for activity against hepatitis B.

## **Maintenance**

---

No regular preventive maintenance is required other than described further in this chapter.

Technical documentation is available in the product service documentation which is available from your local support organization.

## Safety Directions

---

**WARNING:**

Only qualified and authorized personnel shall operate this system. In this context 'qualified' means those persons legally permitted to operate this equipment in the jurisdiction in which the equipment is being used, and 'authorized' means those persons authorized by the authority controlling the use of the equipment. Full use must be made of all radiation protection features, devices, systems, procedures and accessories.

**WARNING:**

Improper changes, additions, maintenance or repair of the equipment or the software can lead to personal injury, electrical shock and damage to the equipment. Safety is only guaranteed when changes, additions, maintenance or repairs are carried out by an Agfa certified field service engineer. A non certified engineer performing a modification or service intervention on a medical device, acts on his own responsibility and makes the warranty void.

**WARNING:**

The user is responsible for judging image quality and controlling environmental conditions for diagnostic softcopy or print viewing.

**WARNING:**

System unavailability due to hardware or software failure. If the product is used in critical clinical workflows, a backup system has to be foreseen.

**WARNING:**

Always double check your exposure parameter settings prior to exposing the patient.

**WARNING:**

Responsibility for risks related to the use of the original X-ray system remains with the user.

**CAUTION:**

Strictly observe all warnings, cautions, notes and safety markings within this document and on the product.



**CAUTION:**

Damaged grid. Reduced image quality. Please handle the grids with special care.



**CAUTION:**

Patients with a BMI above 37 can cause missing lead markers in the overlay. It may be necessary to use other methods to have a correct diagnosis.



**CAUTION:**

While every care has been taken, it is possible that minor errors still exist in the product. It is unlikely that a minor error could result in incorrect (unexpected) device operation.

# Basic Workflow

---

## Topics:

- *Retrieve the patient info*
- *Select the exposure*
- *Prepare the examination*
- *Prepare the Full Leg Full Spine configuration*
- *Check the exposure settings*
- *Execute the exposures*
- *Perform a quality control*
- *Finalize the examination*

## Retrieve the patient info

---

On the NX application:

1. When a new patient comes in, define the patient info for the exam.
2. Start the exam.

## Select the exposure

---



**WARNING:**

Do not start the FLFS examination when the battery level of the mobile X-ray system is critical.

On the NX application:

1. In the Image Overview pane of the Examination window, select the thumbnail for the DR Full Leg Full Spine (FLFS) examination.
2. In the Image Detail pane, click **Start FLFS**.  
For each partial image, a thumbnail is displayed in the **Image Overview** pane.

## Prepare the examination

---

Position the patient.



**WARNING:**

Monitor the patient position (hands, feet, fingers, etc.) with special care to avoid injury to the patient caused by unit movements. Patient hands must be kept away from mobile components of the unit. Intravenous tubing, catheters and other patient connected lines should be routed away from moving equipment.



**WARNING:**

Secure all moveable parts in position before the device can be used for X-ray exposures.

## Prepare the Full Leg Full Spine configuration

In the examination room, position the mobile X-Ray system and the mobile FLFS detector slot:

1. Position the mobile X-ray system above the patient with the X-ray tube centered on the region of interest.
2. Tilt the FLFS detector slot to vertical position and insert the DR detector.

Always use a DR detector with handle unit.



### WARNING:

Wrong image orientation will cause the stitching to fail. Follow the instructions in the user manual of the DR detector for positioning the detector in the bucky.

3. Read on the ruler the relative position of the FLFS detector slot, representing how far the telescopic arm is extended.

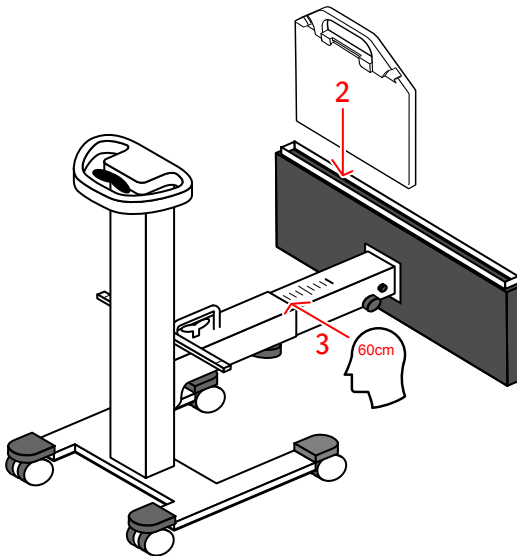

4. Tilt the FLFS detector slot to horizontal position. Fasten the knob of the tilting mechanism.
5. Position the FLFS detector slot under the patient.
6. Raise the FLFS detector slot to the highest position.

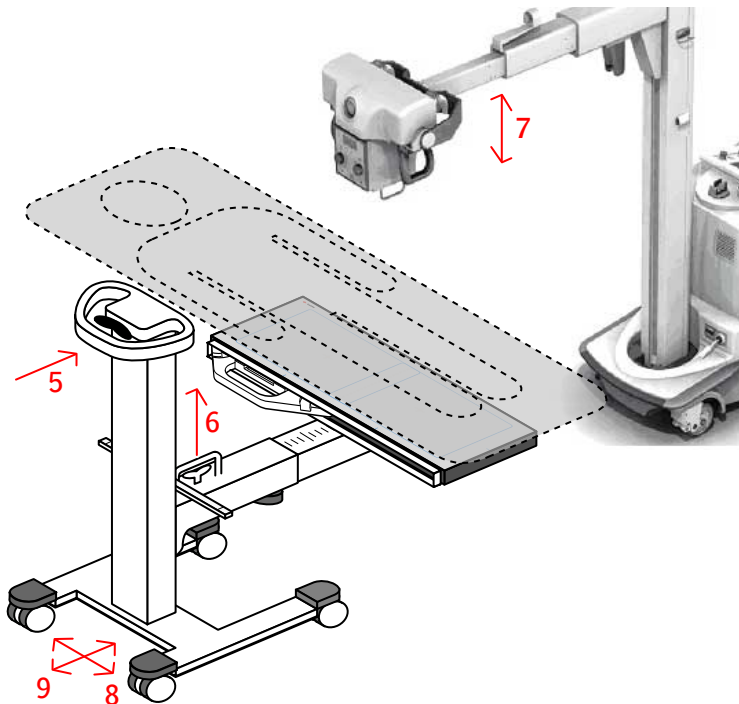

7. Adjust the height of the X-ray tube. The SID can be 100 cm, 115 cm or 130 cm.

Use the rod with position indicators and the collimator laser light as a reference. The SID is reached when the double laser line coincide with the corresponding marker the rod.

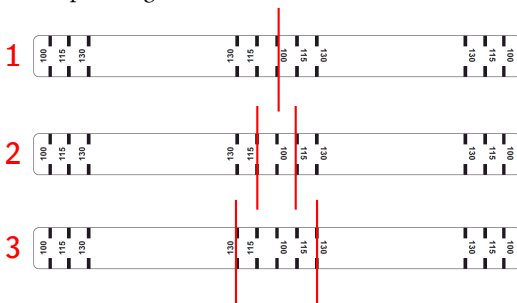

1. SID is 100 cm when both laser lines coincide on the 100 mm center mark.
  2. SID is 115 cm when the two laser lines are visible on the two 115 cm center marks.
  3. SID is 130 cm when the two laser lines are visible on the two 130 cm center marks.
8. Center the FLFS detector slot in longitudinal direction.



## Check the exposure settings

---

In the operator room at the software console:

The NX Image Overview pane displays the empty thumbnails for the exposures that are required for the examination.

Check if the settings for patient size and X-Ray tube load that are displayed on the console are suitable for the examination.



**Figure 2: Settings for patient size and X-ray tube load**

Setting the patient size only affects exposures with AEC.

## Execute the exposures



### CAUTION:

The patient carrier and the mobile FLFS detector slot must be fixed into position before exposure.

1. Shift the DR detector inside the FLFS detector slot to the first position.

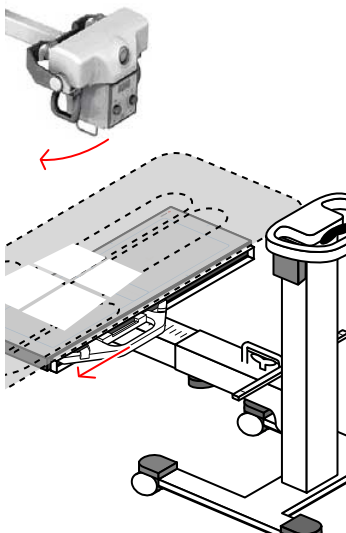

2. Rotate the X-ray tube on its transversal axis.

Use the rod with position indicators and the collimator laser light as a reference. The laser line closest to the center of the ruler should align to the corresponding mark on the rod.

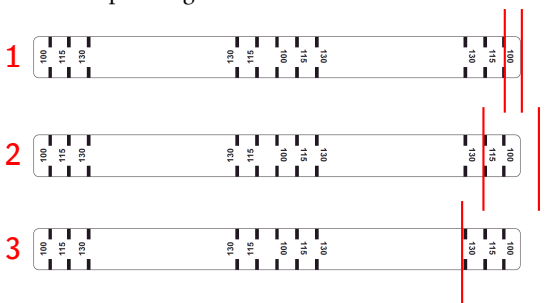

1. Laserline indication for X-ray tube orientation with a SID of 100 cm.
2. Laserline indication for X-ray tube orientation with a SID of 115 cm.

3. Laserline indication for X-ray tube orientation with a SID of 130 cm.
3. Take a safe distance from the X-ray tube.

**CAUTION:**

Excessive user or operator radiation exposure. Always keep a distance of at least 2 meters from the focal spot and X-ray beam, protect body and do not expose hands, arms or other parts of the body to the primary beam.

4. Press the exposure button to acquire the first partial image. The partial image is sent to the NX workstation.

**WARNING:**

During exposure ionizing radiation is emitted by the X-ray system. To indicate the presence of ionizing radiation, the radiation indicator on the control console lights up.

5. Repeat previous steps to acquire the partial image for the second position.

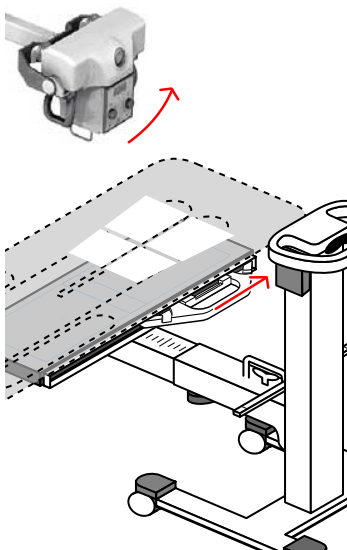

In the operator room at the NX workstation:

- A green OK mark appears on all thumbnails for which exposures are going to be made during the examination.
- The image is acquired from the DR detector and displayed in the thumbnail.
- If collimation is applied, the image is automatically cropped at the collimation borders.
- The actual X-Ray exposure parameters are sent back from the console to the NX workstation.

## Perform a quality control

In the operator room at the NX workstation, the DR Full Leg Full Spine image is displayed in the Stitching pane.









**Figure 3: Stitching pane**

Stitching is applied based on grid markers in the stitching grid and a correction is applied based on the alignment of the anatomical information in the image.

The stitching parameters are displayed on the right side of the image:

**Table 1: Stitching parameters**

| Button  | Parameter  |
|---|--|
|  | Vertical correction, in respect to the stitching grid, for the alignment of the anatomical information in the image.   |
|  | Horizontal correction, in respect to the stitching grid, for the alignment of the anatomical information in the image. |

| Button  | Parameter   |
|---|---|
|  | Indication that automatic stitching has been performed based on the alignment of the anatomical information in the image. |
|  | Indication that patient movement is detected.   |
|  | Indication that automatic stitching has been performed based on the stitching grid.                                       |
|  | Indication that manual corrections have been applied to the alignment of the partial images.                              |

**CAUTION:**

Patient movement can cause inaccurate alignment of the partial images. Patient movement is not always detected by the system. The user is responsible for observation of the movement of the patient during the examination.

To perform quality control:

1. If required, adjust the stitching.
2. Click **Accept**.

Depending on the configuration settings, the stitching parameters are added to the image as a text annotation.

The text annotation contains following information:

**Table 2: Annotations**

|   |  |
|---|--|
| V | Vertical correction, in respect to the stitching grid, for the alignment of the anatomical information in the image.   |
| H | Horizontal correction, in respect to the stitching grid, for the alignment of the anatomical information in the image. |

|   |   |
|---|---|
| M | Indication that manual corrections have been applied to the alignment of the partial images.                              |
| G | Indication that automatic stitching has been performed based on the stitching grid.                                       |
| A | Indication that automatic stitching has been performed based on the alignment of the anatomical information in the image. |
| Y | Indication that patient movement is detected.   |
| N | Indication that no patient movement is detected.  |



**Figure 4: Example of a text annotation containing stitching parameters**

3. Prepare the image for diagnosis by using e.g. L/R markers or annotations.
4. If the image is OK, send the image to a hardcopy printer and/or PACS (Picture Archiving and Communication System).

#### Related Links

[To stitch a set of partial images](#) on page 38

[Manually adjusting a DR Full Leg Full Spine image](#) on page 36

[Rejecting a DR Full Leg Full Spine image](#) on page 44

## **Finalize the examination**

---

1. Unlock the wheels of the mobile FLFS detector slot.
2. Lower the FLFS detector slot.
3. Move the FLFS detector slot away from the patient carrier.
4. Remove the DR detector.
5. Move the mobile FLFS detector slot to its parking position and activate the brakes on the wheels to prevent unintended movement.

# Advanced Operation

---

## Topics:

- *Manually adjusting a DR Full Leg Full Spine image*
- *Rejecting a DR Full Leg Full Spine image*
- *Making measurements*

## **Manually adjusting a DR Full Leg Full Spine image**

---

### **Topics:**

- *To rotate all partial images*
- *To stitch a set of partial images*
- *To align the partial images based on their projection on the stitching grid*
- *To align the partial images based on the analysis of the anatomical information in the image*
- *To manually align two partial images*
- *To turn the black borders or cropping on or off*
- *To save the stitched image*

## To rotate all partial images

Rotate all partial images

- Click the following button to rotate 90° clockwise:



**Figure 5: Rotate clockwise**

- Click the following button to rotate 90° counterclockwise:



**Figure 6: Rotate counterclockwise**

## To stitch a set of partial images

To stitch a set of partial images:

1. In NX, go to the **Examination** window.
2. In the Image Overview pane, select the thumbnail of one of the partial images.
3. Click **Stitch Images**.

The Stitching pane is displayed.

Stitching is applied based on grid markers in the stitching grid and a correction is applied based on the alignment of the anatomical information in the image.

The area of the image where two partial images are stitched together is indicated by the stitching tools displayed on the right side of the image. In this area, the two partial images slightly overlap. If the anatomical structures in the overlapping area are not aligned, stitching can be adjusted manually.

## To align the partial images based on their projection on the stitching grid

To align the partial images based on their projection on the stitching grid:

Click **Grid**.

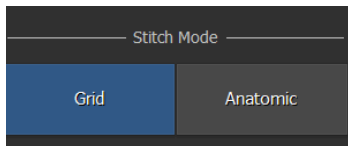

**Figure 7: Stitch mode: grid**

The anatomical structure in the partial images may not be aligned, due to patient movement during the examination.

The values of the horizontal and vertical correction are set to zero. Next to the stitching areas the following label is displayed.

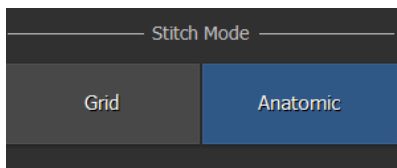

**Figure 8: Stitching tools: align partial images**

## To align the partial images based on the analysis of the anatomical information in the image

To align the partial images based on the analysis of the anatomical information in the image:

Click **Anatomic**.



**Figure 9: Stitch mode: anatomic**

The anatomical structures in the overlapping areas are aligned by automatically shifting the partial images in vertical and horizontal direction.

The new alignment is applied to each stitching area. Next to the stitching areas this label is displayed, as well as the vertical and horizontal relative position of the partial images.



**Figure 10: Stitching tools: align partial images (via anatomical information)**

## To manually align two partial images

To manually align two partial images:

1. Click the **Alignment** button.



**Figure 11: Alignment button**

A detail of the overlapping area is displayed.

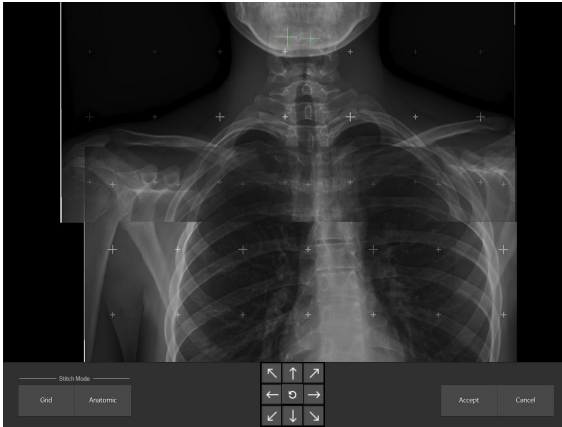

**Figure 12: Detail overlapping area**

2. Align the two partial images:

**Table 3: Manual alignment**

|   |   |
|---|---|
| Adjusting the position of the lower image | <p>Right click-hold the image and drag the mouse arrow to any direction.</p> <p>Press the SHIFT or CTRL button while dragging the mouse arrow to adjust the vertical or horizontal alignment only.</p> <p>Use the arrow keys on the keyboard.</p> <p>Click the arrow buttons on the screen.</p> |
| Roaming over the images                   | <p>Left click-hold the image and drag the mouse arrow to any direction.</p>   |
| Zooming in/out on the images              | <p>Use the scroll wheel on the mouse.</p>   |

|                                  |   |
|----------------------------------|---|
| Restoring the original alignment | Click the <b>Revert</b> button.<br><br><b>Figure 13: Revert button</b> |
|----------------------------------|---|

The relative position of the partial images, compared to their initial relative position, is illustrated by two crosshairs displayed in the image, each of which is locked to the position of one of the partial images.

3. If the anatomical structures in the partial images are aligned, click **Accept** to confirm.

Next to the stitching areas this label is displayed, as well as the vertical and horizontal relative position of the partial images.



**Figure 14: Stitching tools: manual alignment**

## To turn the black borders or cropping on or off

To turn the black borders or cropping on or off:

Click the following icon:



**Figure 15: Crop/uncrop button**

## To save the stitched image

To save the stitched image:

Click Accept.

The DR Full Leg Full Spine image is available in the examination. Depending on the configuration settings, the stitching parameters are added to the image as a text annotation.



*Note: After saving, the DR Full Leg Full Spine image cannot be adjusted. The same set of partial images can be used to create another DR Full Leg Full Spine image.*

## Rejecting a DR Full Leg Full Spine image

---

By rejecting an image you indicate that the image is not suitable for diagnosis and that a retake is needed. Rejecting an image does not remove the image from the exam.

To reject a DR Full Leg Full Spine image:

1. Reject each partial image.
2. If the DR Full Leg Full Spine image was created, reject this image also.

No images will be sent and a thumbnail for a new DR Full Leg Full Spine examination is created.

## Making measurements

Distance measurements on DR Full Leg Full Spine images in NX are calibrated based on the Estimated Radiographic Magnification Factor. The calibration factor is calculated based on:

1. the distance between the patient and the stitching grid of the Full Leg Full Spine wall stand.
2. the Source Image Distance (SID).

Both values can be entered by clicking the **ERMF Calibration** button in the Editing environment of the NX software.



**Figure 16: ERMF Calibration**



*Note: If the distance between the patient and the stitching grid is not entered (or entered as zero), no calibration is applied on NX. Measurements on the DR Full Leg Full Spine image are based on the projection of the object on the stitching grid.*

To make measurements, see the NX User Manual on Adding annotations to an image and using the measurement tools.

To modify the Estimated Radiographic Magnification Factor, see the NX User Manual on Adding an Estimated Radiographic Magnification Factor (ERMF).

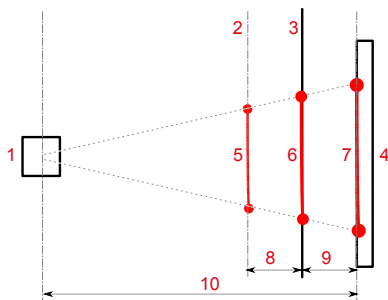

1. X-ray tube
2. Patient location
3. Stitching grid
4. DR Detector
5. Distance to be measured on the object, in a plane parallel to the stitching grid
6. Projection of the object on the stitching grid. This is the measured distance on the DR Full Leg Full Spine image on NX if no calibration is applied.

7. Projection of the object on the DR Detector. This is the measured distance on a partial image on NX.
8. Distance between the plane in which the measurement is made and the stitching grid. This distance is estimated by the user and entered at the touch screen console while preparing the examination.
9. Distance between the stitching grid and the DR Detector.
10. Source image distance (SID). This distance is received together with the X-Ray generator parameters.

**Figure 17: Making measurements on DR Full Leg Full Spine images**

The respective distances between the plane in which the measurement is made, the stitching grid, the DR Detector and the X-ray tube are used to calculate the Estimated Radiographic Magnification Factor to calibrate the distance measurement on NX.

**Related Links**

[\*Accuracy of Measurements\*](#) on page 16

# Problem solving

---

## Topics:

- *Anatomical stitching is not optimal*
- *Stitching fails*

## Anatomical stitching is not optimal

---

**Table 4: Problem: Anatomical stitching is not optimal**

|                |   |
|----------------|---|
| Details        | <p>The anatomic information in the partial images cannot be automatically fully aligned. If the result of automatic stitching based on the alignment of the anatomical information in the image is suspicious because of possible movement of the patient during the examination, this icon is displayed in the Stitching pane:</p>  |
| Cause          | <p>The patient has changed position during the examination.</p>   |
| Brief Solution | <p>Manually adjust the DR Full Leg Full Spine image.<br/>If the partial images cannot be manually adjusted, click <b>Cancel</b> in the Stitching pane. No DR Full Leg Full Spine image is available.</p>  |

## Stitching fails

---

**Table 5: Problem: Stitching fails**

|                |   |
|----------------|---|
| Details        | The partial images cannot be stitched because the grid markers in the stitching grid are not visible in the partial images. |
| Cause          | The stitching grid was not used for the examination.  |
| Brief Solution | Click <b>Cancel</b> in the Stitching pane. No DR Full Leg Full Spine image is available.                                    |

# Technical Data

---

## Mobile FLFS detector slot technical data

---

**Table 6: Full Leg Full Spine wall stand technical data**

|   |  |
|---|--|
| Manufacturer  | Reina Imaging<br>6107 Lou St., Crystal Lake, IL 60014<br>USA |
| Original model number   | PPTS340T   |
| Dimensions<br>(vertical column collapsed, horizontal arm retracted) | Width: 519 mm<br>Height: 1027 mm<br>Depth: 978 mm            |
| Weight approx.  | 92 kg  |
| Mylar Back X-ray Absorption   | < 1.2 mm Al  |
| Environmental requirements  |  |
| Room temperature  | -20°C to 40°C  |
| Environmental requirements (storage)                                |  |
| Temperature   | -20°C to 40°C  |
| Environmental requirements (transport)                              |  |
| Temperature   | -20°C to 40°C  |
| Expected product lifetime   | 7 years  |