

AGFA HEALTHCARE DICOM Conformance Statement

→ **IMPAX RIS v5.4.3; v5.5.x; v5.6.x; v5.7.x**

Document No. 001212 Revision 2.2
NodeID LiveLink : 19530802

When printed, this is NOT a controlled copy

Document Information

Service-related contact information worldwide	All service-related contact information is available on this URL→	http://www.agfa.com/en/he/support/support_service/index.jsp

Issued by:
Agfa HealthCare
SIV Connectivity
Septestraat 27
B-2640 Mortsel
Belgium

tel: +32 3 444 75 88
email: connectivity@agfa.com

Agfa shall not be liable for errors contained herein or for incidental or consequential damages in connection with the furnishing, performance or use of this publication. Agfa reserves the right to revise this publication and to make changes to its content at any time, without obligation to notify any person or entity of such revisions and changes. This publication may only be used in connection with the promotion, sales, installation and use of Agfa equipment.

Copyright © December, 09
Agfa HealthCare
All rights reserved

Conformance Statement Overview

IMPAX RIS Dicomserver is the imaging device connectivity service of Agfa's RIS system and acts as a Modality Worklist Management Service Class Provider and a Modality Performed Procedure Step Manager.

IMPAX RIS Dicomserver is only installed when MPPS is required or when there's no Agfa PACS, otherwise the worklists are provided by Connectivity Manager or PACS Broker.

Custom worklists can be configured per modality.

Modality performed procedure step information is only used to update procedure statuses and to store radiation dose information in the RIS.

Image Availability Notification is used to update availability status of the images in RIS database.

Table 1.1-1: Network Services Supported

SOP Classes	User of Service (SCU)	Provider of Service (SCP)
Transfer	No	No
Query/Retrieve	No	No
Workflow Management		
Modality Worklist Information Model – FIND	No	Yes
Modality Performed Procedure Step	Yes	Yes
Instance Availability Notification	No	Yes
Print Management	No	No

Table 1.1-2: Media Services Supported

Media Storage Application Profile	Write Files (FSC or FSU)	Read Files (FSR)
Compact Disk - Recordable	No	No
Magneto-Optical Disk	No	No
DVD	No	No

Table of Contents

1	Introduction	6
1.1	Revision Record	6
1.2	Purpose and Intended Audience of this Document	6
1.3	General Remarks	6
1.3.1	Integration and Validation Activities	6
1.3.2	Future Evolution	7
1.4	Acronyms and Abbreviations	7
1.5	Related Documents	8
2	Networking	9
2.1	Implementation Model	9
2.1.1	Application Data Flow Diagram	9
2.1.2	Functional Definitions of AE's	9
2.1.2.1	Functional Capability of C-FIND Modality Worklist	9
2.1.3	Functional Capability of N-CREATE and N-SET Modality Performed Procedure Step. 10	
2.1.3.1	Functional Capability of N-CREATE Instance Availability Notification.	10
2.1.4	Sequencing of Real World Activities	10
2.2	AE Specifications	11
2.2.1	IMPAX-RIS Specification	11
2.2.1.1	SOP Classes Supported	11
2.2.1.2	Association Establishment Policies	11
2.2.1.2.1	General	11
2.2.1.2.2	Number of Associations	11
2.2.1.2.3	Asynchronous Nature	11
2.2.1.2.4	Implementation Identifying Information	12
2.2.1.3	Association Initiation Policies	12
2.2.1.3.1	Forwarding MPPS messages	12
2.2.1.3.1.1	Description and Sequencing of Activity	12
2.2.1.3.1.2	Proposed Presentation Contexts	13
2.2.1.4	Association Acceptance Policies	13
2.2.1.4.1	Receive Query for Modality Worklist	13
2.2.1.4.1.1	Description and Sequencing of Activity	13
2.2.1.4.1.2	Accepted Presentation Contexts	14
2.2.1.4.1.3	SOP Specific Conformance for Modality Worklist SOP Class	14
2.2.1.4.2	Receive MPPS Request	17
2.2.1.4.2.1	Description and Sequencing of Activity	17
2.2.1.4.2.2	Accepted Presentation Contexts	18
2.2.1.4.2.3	SOP Specific Conformance for MPPS SOP Class	18
2.2.1.4.3	Receive Instance Availability Notification	19
2.2.1.4.3.1	Accepted Presentation Contexts	20
2.2.1.4.3.2	SOP Specific Conformance for IAN SOP Class	20
2.3	Network Interfaces	20
2.3.1	Physical Medium Support	20
2.3.2	Additional Protocols	20
2.4	Configuration	21
2.4.1	AE Title/ Presentation Mapping	21
2.4.1.1	Local AE Titles	21

2.4.1.2	Remote AE Titles.....	21
2.4.1.2.1	Remote SCP	21
2.4.2	Configuration Parameters.....	21
3	Media Interchange.....	22
4	Support for Extended Character Sets.....	23
5	Security	24
5.1	Security Profiles	24
5.2	Association Level Security	24
5.3	Application Level Security.....	24
6	Annexes	25
6.1	IOD Contents.....	25
6.1.1	Usage of Attributes from Basic Worklist Management IOD.....	25
6.1.2	Usage of Attributes from Modality Performed Procedure Step IOD.....	25
6.1.3	Usage of Attributes from Instance Availability Notification IOD	25

1 INTRODUCTION

1.1 Revision Record

Revision Number	Date	Reason for Change
1.0	February 26, 2003	Initial version
1.1	July 3, 2006	Updated layout
2.0	January 24 , 2008	Update Information and layout
2.1	September 02 , 2009	Update for RIS 5.6, add table 1.3-1, update table 2.2-14
2.2	December 02 , 2009	Update conformance statement overview text and update table 1.3-1 for IMPAX RIS v5.7

1.2 Purpose and Intended Audience of this Document

This document is a DICOM Conformance Statement for the DICOM Services of the IMPAX RIS product.

The user of this document is involved with system integration and/or software design. We assume that the reader is familiar with the terminology and concepts that are used in the DICOM 3.0 standard and the IHE Technical Framework.

Readers not familiar with DICOM 3.0 terminology should first read the appropriate parts of the DICOM standard itself, prior to reading this conformance statement.

Although the use of this conformance statement in conjunction with the DICOM 3.0 standard is intended to facilitate communication with Agfa IMPAX RIS, it is not sufficient to guarantee, by itself, the inter-operation of the connection. The following issues need to be considered:

1.3 General Remarks

IMPAX RIS Dicomserver is part of the 2005.3.1 ; 2005.3.3 and 2005.3.4 Connectivity Suite.

Table 1.3-1 RIS version overview

		Connectivity Version			
		2005.2.0	2005.3.1	2005.3.3	2005.3.4
RIS version	5.4.3 (incl. I-Plan 6.3)	X	X		
	5.5 (incl. I-Plan 6.3)		X		
	5.5.1 (incl. I-Plan 6.3)		X	X	X
	5.6 (incl. I-Plan 6.3)			X	X
	5.7 (incl. I-Plan 6.3)				X

1.3.1 Integration and Validation Activities

The integration of any device into a system of interconnected devices goes beyond the scope of the DICOM 3.0 standard and this conformance statement when *interoperability* is desired. The responsibility for analyzing the applications requirements and developing a solution that integrates the Agfa equipment with other vendors' systems is the user's responsibility and should not be underestimated.

In some circumstances it might be necessary to perform a validation to make sure that functional interoperability between the Agfa equipment and non-Agfa devices works as expected. The user should ensure that any non-Agfa provider accepts responsibility for any validation required for their connection with the Agfa equipment.

1.3.2 Future Evolution

As the DICOM 3.0 standard evolves to meet the user's growing requirements and to incorporate new features and technologies, Agfa will follow the evolution of the standard. This evolution of the standard may require changes to devices that have implemented DICOM 3.0. The user should ensure that any non-Agfa provider, who connects with Agfa devices, also plans for future evolution of the DICOM standard. A refusal to do so may result in the loss of functionality and/or connectivity between the different products.

1.4 Acronyms and Abbreviations

Definitions, terms and abbreviations used in this document are defined within the different parts of the DICOM standard. Abbreviations and terms are as follows:

AE	DICOM Application Entity
AET	Application Entity Title
ASCE	Association Control Service Element
CD-R	Compact Disk Recordable
DICOM	Digital Imaging and Communications in Medicine
FSC	File-Set Creator
FSU	File-Set Updater
FSR	File-Set Reader
GSDF	Grayscale Standard Display Function
GSPS	Grayscale Softcopy Presentation State
IAN	Instance Availability Notification
IE	Information Entity
IOD	(DICOM) Information Object Definition
ISO	International Standard Organization
MPPS	Modality Performed Procedure Step
MSPS	Modality Scheduled Procedure Step
PDU	DICOM Protocol Data Unit
SCU	DICOM Service Class User (DICOM client)
SCP	DICOM Service Class Provider (DICOM server)
SOP	DICOM Service-Object Pair
UID	Unique Identifier
VR	Value Representation

1.5 **Related Documents**

- ACR-NEMA Digital Imaging and Communications in Medicine (DICOM) V3.0.
- IHE Radiology Technical Framework Revision 6 – Final Text, May 2005

2 NETWORKING

2.1 Implementation Model

2.1.1 Application Data Flow Diagram

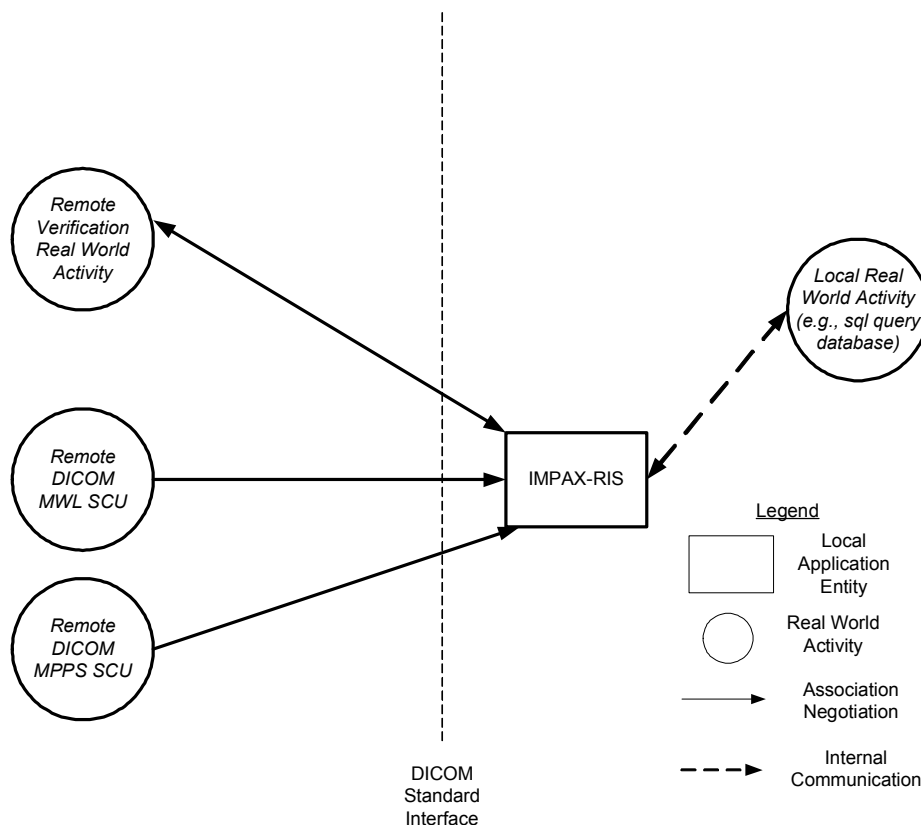

Figure 2.1-1: Functional Overview – Application Data Flow

- The DICOM Query is translated into a SQL Query which is executed on the RIS database. The result of the query is translated into a DICOM response.
- The DICOM instance availability is used to track image availability in the RIS database.
- The DICOM MPPS is used to update the procedure status in the RIS database.

2.1.2 Functional Definitions of AE's

2.1.2.1 Functional Capability of C-FIND Modality Worklist.

IMPAX RIS Dicomserver will accept requests to C-FIND a modality work list. These modality work lists are queried from the database through a SQL interface.

2.1.3 Functional Capability of N-CREATE and N-SET Modality Performed Procedure Step.

IMPAX RIS Dicomserver accepts N-CREATE and N-SET Modality Performed Procedure Steps. The IMPAX RIS Dicomserver updates the procedure status in the IMPAX RIS database.

2.1.3.1 Functional Capability of N-CREATE Instance Availability Notification.

IMPAX RIS Dicomserver accepts N-CREATE Instance Availability Notifications and updates image availability status in the RIS database.

2.1.4 Sequencing of Real World Activities

IMPAX RIS Dicomserver must have an installed/working connection with the IMPAX RIS database and with one or more suitable SCU.

Query information is formed on the SCU and then sent to IMPAX RIS Dicomserver. The requesting device must have the DICOM parameters set and configured prior to using the modality's query facilities. The set and configuration of DICOM Modality Worklist SCUs is done using the tools provided by the device's vendor.

As a result of the request IMPAX RIS Dicomserver queries the RIS database and sends a list of tasks that have been scheduled for the requesting modality out of which the device's operator can select the item which is to be performed in reality.

If IMPAX RIS Dicomserver receives an N-CREATE, at the start of the imaging, or a N-SET, at the end of the imaging, it updates the procedure status in the RIS database.

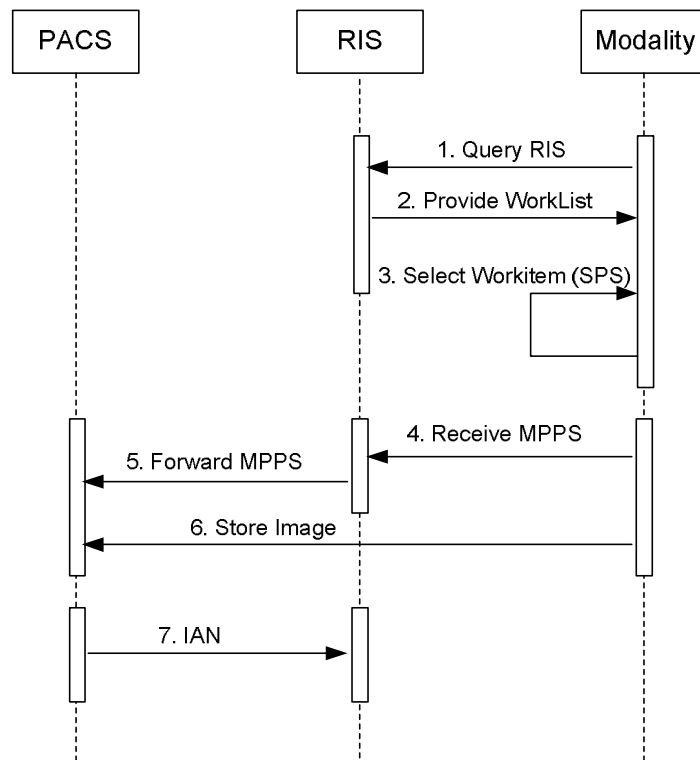

Figure 2.1-2: sequencing constraints

2.2 AE Specifications

2.2.1 IMPAX-RIS Specification

2.2.1.1 SOP Classes Supported

This Application Entity provides Standard Conformance to the following SOP Class(es):

Table 2.2-1: SOP Class(es)

SOP Class Name	SOP Class UID	SCU	SCP
Workflow Management			
Modality Worklist Information Model - FIND	1.2.840.10008.5.1.4.31	No	Yes
Modality Performed Procedure	1.2.840.10008.3.1.2.3.3	No	Yes
Instance Availability Notification	1.2.840.10008.5.1.4.33	No	Yes

2.2.1.2 Association Establishment Policies

2.2.1.2.1 General

The DICOM standard Application context shall be specified.

Table 2.2-2: DICOM Application Context

Application Context Name	1.2.840.10008.3.1.1.1
--------------------------	-----------------------

2.2.1.2.2 Number of Associations

Table 2.2-3: Number of Associations as an Association Initiator

Maximum number of simultaneous associations initiated	1
---	---

Table 2.2-4: Number of Associations as an Association Acceptor

Maximum number of simultaneous associations accepted	32
--	----

2.2.1.2.3 Asynchronous Nature

Table 2.2-5: Asynchronous Nature as an Association Initiator

Maximum number of outstanding asynchronous transactions	X
---	---

IMPAX RIS Dicomserver allows a single outstanding operation on any association. Therefore, IMPAX RIS Dicomserver does not support asynchronous operations window negotiation, other than the default as specified by the DICOM specification.

2.2.1.2.4 Implementation Identifying Information

Table 2.2-6: DICOM implementation Class and Version

Implementation Class UID	1.3.51.0.1.3
Implementation Version Name	AGFA DTF1.0.64

2.2.1.3 Association Initiation Policies

2.2.1.3.1 Forwarding MPPS messages

2.2.1.3.1.1 Description and Sequencing of Activity

The IMPAX RIS Dicomserver Application Entity forwards the MPPS received from the Modality to the PACS (image manager). This functionality is required in case IMPAX RIS plays the role of IHE MPPS Manager Actor for the IHE profile “Scheduled Workflow” and “Patient Information Reconciliation”.

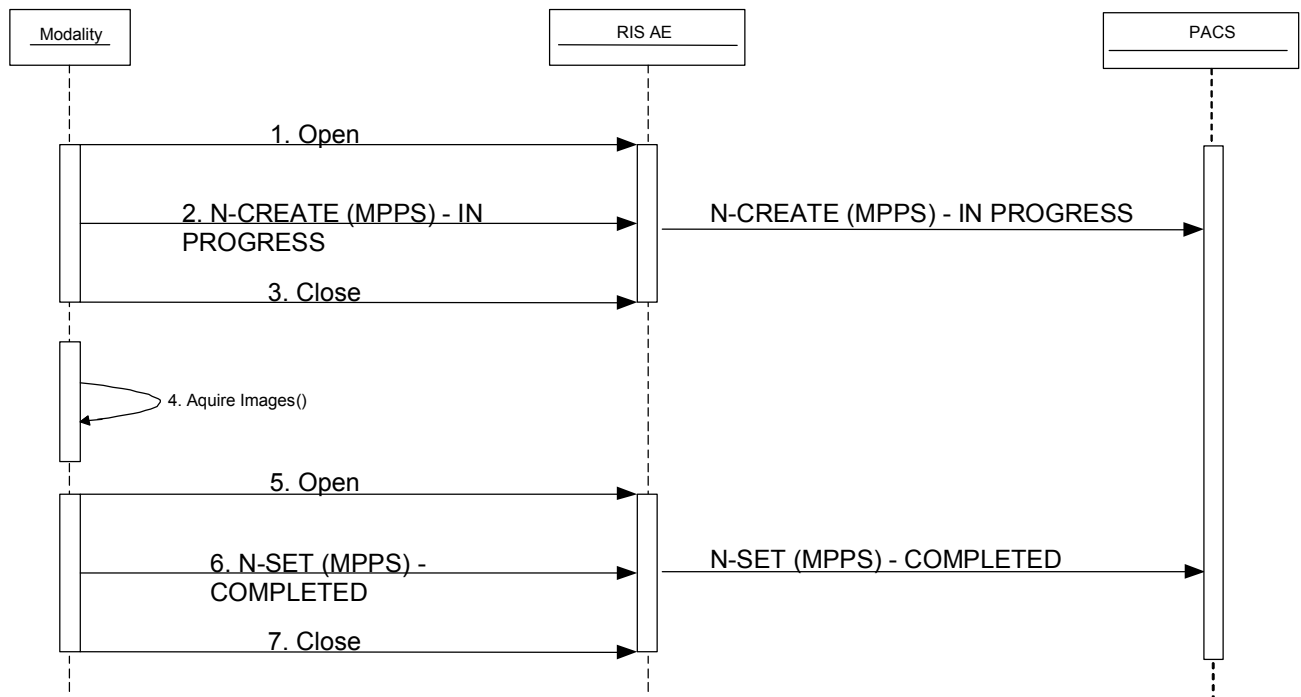

Figure 2.2-1: IMPAX-RIS MPPS forwarding Sequencing Diagram

2.2.1.3.1.2 Proposed Presentation Contexts

Table 2.2-7: Presentation Contexts

Presentation Context Table					
Abstract Syntax		Transfer Syntax		Role	Extended Negotiation
Name	UID	Name List	UID List		
Modality Performed Procedure	1.2.840.10008.3.1.2.3.3	Implicit VR Little Endian	1.2.840.10008.1.2	SCU	None
		Explicit VR Little Endian	1.2.840.10008.1.2.1		

2.2.1.4 Association Acceptance Policies

2.2.1.4.1 Receive Query for Modality Worklist

2.2.1.4.1.1 Description and Sequencing of Activity

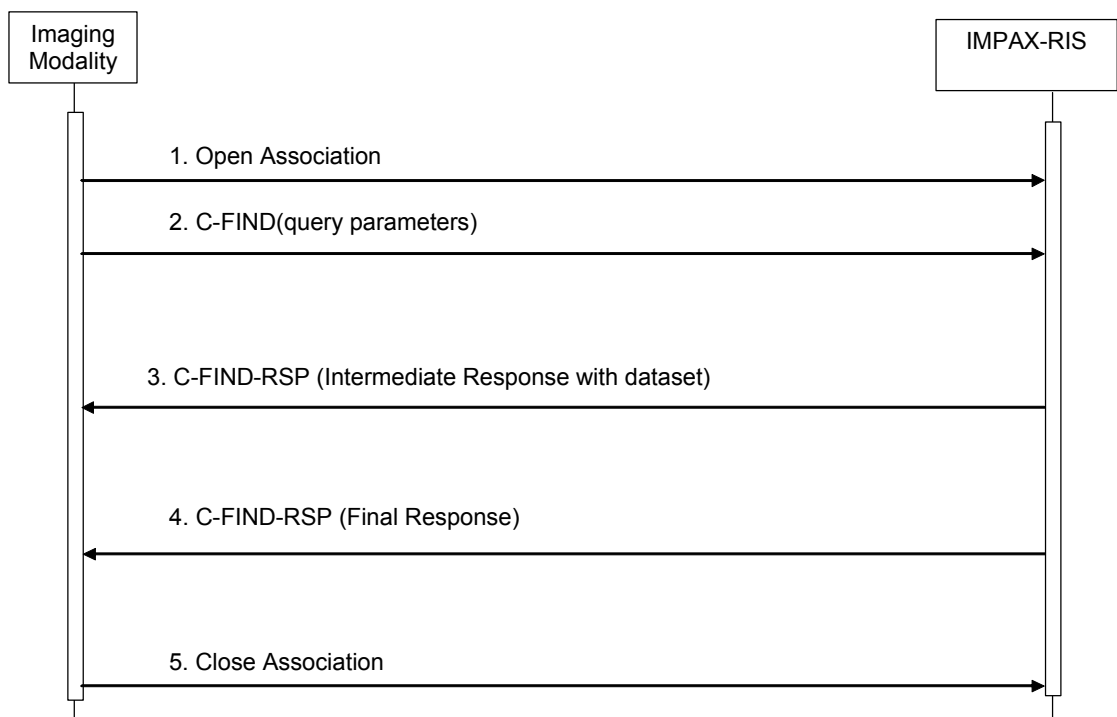

Figure 2.2-2: IMPAX-RIS Sequencing Diagram

2.2.1.4.1.2 Accepted Presentation Contexts

Table 2.2-8: Presentation Contexts

Presentation Context Table					
Abstract Syntax		Transfer Syntax		Role	Extended Negotiation
Name	UID	Name List	UID List		
Modality Worklist Information Model - FIND	1.2.840.10008.5.1.4.31	Implicit VR Little Endian	1.2.840.10008.1.2	SCP	None
		Explicit VR Little Endian	1.2.840.10008.1.2.1		

2.2.1.4.1.3 SOP Specific Conformance for Modality Worklist SOP Class

IMPAX RIS Dicomserver supports all required matching key types:

Table 2.2-9: Matching Key Types

Matching Key Types	
SV	single valued match
WC	wild card match
SQ	sequence match
DR	date range match

IMPAX RIS Dicomserver accepts the following elements and applies the following matching for this SOP class:

Table 2.2-10: Dicomserver Elements and matching

Module	Attribute Name	Tag	Match	Return
Scheduled Procedure Step	Scheduled Procedure Step Sequence	(0040,0100)		1
	>Scheduled Station AE Title	(0040,0001)	SV	1
	>Scheduled Procedure Step Start Date	(0040,0002)	DR	1
	>Modality	(0008,0060)	SV	1
Requested Procedure	Requested Procedure ID	(0040,1001)	SV	1
Imaging Service Request	Accession Number	(0008,0050)	SV	2
Patient Identification	Patient Name	(0010,0010)	WC	1
	Patient ID	(0010,0020)	SV	1

IMPAX RIS Dicomserver supports the following elements in the response:

Table 2.2-11: Dicomserver Supported elements

Module	Attribute Name	Tag	Return
SOP Common	Specific Character Set	(0008,0005)	SV
	Query/Retrieve Level	(0008,0052)	Zero length
Scheduled Procedure Step	Scheduled Procedure Step Sequence	(0040,0100)	SQ

Module	Attribute Name	Tag	Return
	>Scheduled Station AE Title	(0040,0001)	SV or Zero length
	>Scheduled Procedure Step Start Date	(0040,0002)	SV or Zero length
	>Scheduled Procedure Step Start Time	(0040,0003)	SV or Zero length
	>Scheduled Procedure Stop End Date	(0040,0004)	SV or Zero length
	>Scheduled Procedure Stop End Time	(0040,0005)	SV or Zero length
	>Modality	(0008,0060)	SV or Zero length
	>Scheduled Performing Physician	(0040,0006)	SV or Zero length
	>Scheduled Procedure Step Desc.	(0040,0007)	SV or Zero length
	>Scheduled Station Name	(0040,0010)	SV or Zero length
	>Scheduled Procedure Step Location	(0040,0011)	SV or Zero length
	>Scheduled Action Item Code Seq.	(0040,0008)	SQ
	>>Code Value	(0008,0100)	SV or Zero length
	>>Coding Scheme Designator	(0008,0102)	SV or Zero length
	>>Code Meaning	(0008,0104)	SV or Zero length
	>Pre-Medication	(0040,0012)	Zero length
	>Scheduled Procedure Step ID	(0040,0009)	SV or Zero length
	>Requested Contrast Agent	(0032,1070)	Zero length
	>Scheduled Procedure Step Status	(0040,0020)	SV or Zero length
	>Comments on the Scheduled Procedure Step	(0040,0400)	Zero length
Requested Procedure	Requested Procedure ID	(0040,1001)	SV or Zero length
	Requested Procedure Description	(0032,1060)	SV or Zero length
	Reason for Requested Procedure	(0040,1002)	Zero length
	Requested Procedure Code Sequence	(0032,1064)	SQ
	>Code Value	(0008,0100)	SV or Zero length
	>Coding Scheme Designator	(0008,0102)	SV or Zero length
	>Code Meaning	(0008,0104)	SV or Zero length
	Study Instance UID	(0020,000D)	SV or Zero length
	Referenced Study Sequence	(0008,1110)	Zero length
	>Referenced SOP Class UID	(0008,1150)	SV
	>Referenced SOP Instance UID	(0008,1155)	SV
	Requested Procedure Priority	(0040,1003)	SV or Zero length
	Patient Transport Arrangements	(0040,1004)	Zero length
	Requested Procedure Location	(0040,1005)	Zero length
	Requested Procedure Comments	(0040,1400)	SV or Zero length
	Confidentiality Code	(0040,1008)	Zero length
	Reporting Priority	(0040,1009)	Zero length
	Names of Intended Recipients of Results	(0040,1010)	Zero length
Imaging Service Request	Accession Number	(0008,0050)	SV or Zero length
	Imaging Service Request Comments	(0040,2400)	SV or Zero length
	Requesting Physician	(0032,1032)	SV or Zero length
	Requesting Service	(0032,1033)	SV or Zero length
	Referring Physician Name	(0008,0090)	SV or Zero length
	Issue Date of Imaging Service Request	(0040,2004)	Zero length
	Issue Time of Imaging Service Request	(0040,2005)	Zero length
	Placer Order Number / Imaging Service Request	(0040,2016)	Zero length
	Filler Order Number / Imaging Service Request	(0040,2017)	SV or Zero length
	Reason for Imaging Service Request	(0040,2001)	Zero length
	Order Entered by ...	(0040,2008)	Zero length

Module	Attribute Name	Tag	Return
	Order Enterer's Location	(0040,2009)	Zero length
	Order Callback Phone Number	(0040,2010)	Zero length
Visit Identification	Admission ID	(0038,0010)	SV or Zero length
	Issuer of Admission ID	(0038,0011)	Zero length
	Institution Name	(0008,0080)	Zero length
	Institution Address	(0008,0081)	Zero length
Visit Status	Current Patient Location	(0038,0300)	SV or Zero length
Visit Relationship	Referenced Patient Sequence	(0008,1120)	Zero length
	>Referenced SOP Class UID	(0008,1150)	Zero length
	>Referenced SOP Instance UID	(0008,1155)	Zero length
Visit Admission	Admitting Diagnosis Description	(0008,1080)	Zero length
Patient Identification	Patient Name	(0010,0010)	SV or Zero length
	Patient ID	(0010,0020)	SV or Zero length
	Issuer of Patient ID	(0010,0021)	SV or Zero length
	Ethnic Group	(0010,2160)	Zero length
	Other Patient ID	(0010,1000)	Zero length
	Other Patient Name	(0010,1001)	Zero length
	Patient Address	(0010,1040)	SV or Zero length
Patient Demographic	Patient Birth Date	(0010,0030)	SV or Zero length
	Patient Sex	(0010,0040)	SV or Zero length
	Patient Weight	(0010,1030)	Zero length
	Patient's Size	(0010,1020)	Zero length
	Confidentiality Constraint	(0040,3001)	Zero length
	Region of Residence	(0010,2152)	Zero length
	Military Rank	(0010,1080)	Zero length
	Patient Comments	(0010,4000)	Zero length
Patient Medical	Patient State	(0038,0500)	Zero length
	Smoking Status	(0010,21A0)	Zero length
	Additional Patient History	(0010,21B0)	Zero length
	Pregnancy Status	(0010,21C0)	Zero length
	Last Menstrual Date	(0010,21D0)	Zero length
	Medical Alerts	(0010,2000)	Zero length
	Contrast Allergies	(0010,2110)	Zero length
	Special Needs	(0038,0050)	Zero length

Table 2.2-12: IMPAX RIS Dicomsrver Response Status

Service Status	Further Meaning	Error Code	Reason
Success	Success	0000	Operation performed properly, all matches were returned
Error	Processing Failure	C000	No access to RIS database
Pending	More matches to come	FF00	This status is returned with each matching response

2.2.1.4.2 Receive MPPS Request

2.2.1.4.2.1 Description and Sequencing of Activity

After a modality has started the performance of a Procedure Step it should inform the RIS by sending an N-CREATE service request to the RIS Application Entity.

An N-CREATE event with status "IN PROGRESS" will update the procedure status in IMPAX RIS to "PROCEDURE STARTED".

At the end of the Performed Procedure Step the modality should send a N-SET command with all other mandatory attributes to RIS Application Entity. An N-SET event with status "COMPLETED" will update the procedure status in IMPAX RIS to "PROCEDURE COMPLETE".

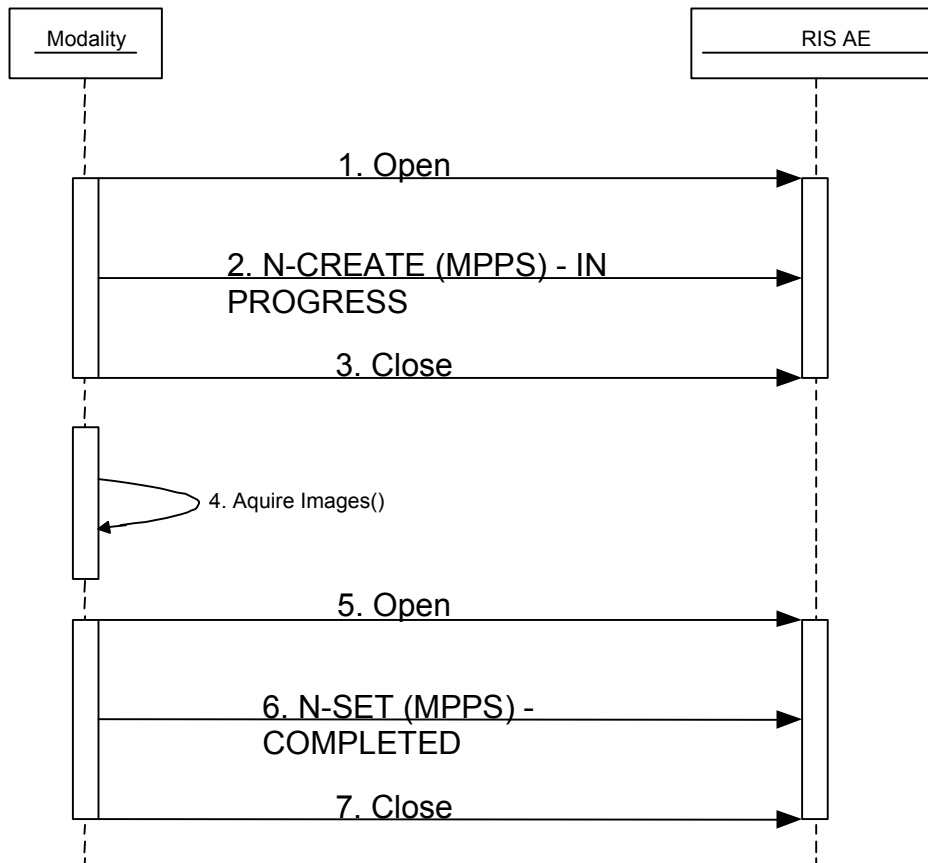

Figure 2.2-3: IMPAX-RIS Sequencing Diagram

2.2.1.4.2.2 Accepted Presentation Contexts

Table 2.2-13: Presentation Contexts

Presentation Context Table					
Abstract Syntax		Transfer Syntax		Role	Extended Negotiation
Name	UID	Name List	UID List		
Modality Performed Procedure	1.2.840.10008.3.1.2.3.3	Implicit VR Little Endian	1.2.840.10008.1.2	SCP	None
		Explicit VR Little Endian	1.2.840.10008.1.2.1		

2.2.1.4.2.3 SOP Specific Conformance for MPPS SOP Class

IMPAX RIS Dicomserver supports all attributes as described in the Dicom Standard part 3.3 for MPPS, however IMPAX RIS Dicomserver only stores the attributes mentioned in the table below.

Table 2.2-14: Attributes supported

Attribute Name	Tag	N-Create	N-Set	Comments
PERFORMED PROCEDURE STEP INFORMATION MODULE ATTRIBUTES				
Schedule Step Attribute Sequence	(0040,0270)	X		
>Study Instance UID	(0020,000d)	X		
>Accession Number	(0008,0050)	X		
>Scheduled Protocol Code Sequence	(0040,0008)	X		
>>Code Value	(0008,0100)	X		
>>Code Meaning	(0008,0104)	X		
Patient ID	(0010,0020)	X		
Patient Name	(0010,0010)	X		
Patient Birth Date	(0010,0030)	X		
Patient Sex	(0010,0040)	X		
Performed Procedure Step ID	(0040,0253)	X		
Performed Procedure Step Start Date	(0040,0244)	X		
Performed Procedure Step Start Time	(0040,0245)	X		
Performed Procedure Step Status	(0040,0252)	X	X	
Procedure Code Sequence	(0008,1032)	X	X	
>Code Value	(0008,0100)	X	X	
>Code Meaning	(0008,0104)	X	X	
Modality	(0008,0060)	X		
Performed Protocol Code Sequence	(0040,0260)	X	X	
>Code Value	(0008,0100)	X	X	
>Code Meaning	(0008,0104)	X	X	
RADIATION DOSE MODULE ATTRIBUTES				
Total Number of Exposures	(0040,0301)	X	X	
Entrance Dose	(0040,0302)	X	X	Only used if (0040,8302) is empty

Attribute Name	Tag	N-Create	N-Set	Comments
Entrance Dose in mGy	(0040,8302)	X	X	
Image and Fluoroscopy Area Dose Product	(0018,115E)	X	X	
Comments on Radiation Dose	(0040,0310)	X	X	Used by certain modalities
Exposure Dose Sequence	(0040,030E)	X	X	
>KVp	(0018,0060)	X	X	
>Exposure Time	(0018,1150)	X	X	Only used if (0018,8150) is empty
CR IMAGE MODULE ATTRIBUTES				
KVP	(0018,0060)	X	X	
X-ray Tube Current	(0018,1151)	X	X	
Exposure	(0018,1152)	X	X	Only used if (0018,1153) is empty
Exposure in μ As	(0018,1153)	X	X	

Table 2.2-15: IMPAX RIS Dicomserver MPPS Response Status

Service Status	Further Meaning	Error Code	Reason
Success	Success	0000	Operation performed properly, all matches were returned
Error	Processing Failure	C000	No access to RIS database

2.2.1.4.3 Receive Instance Availability Notification

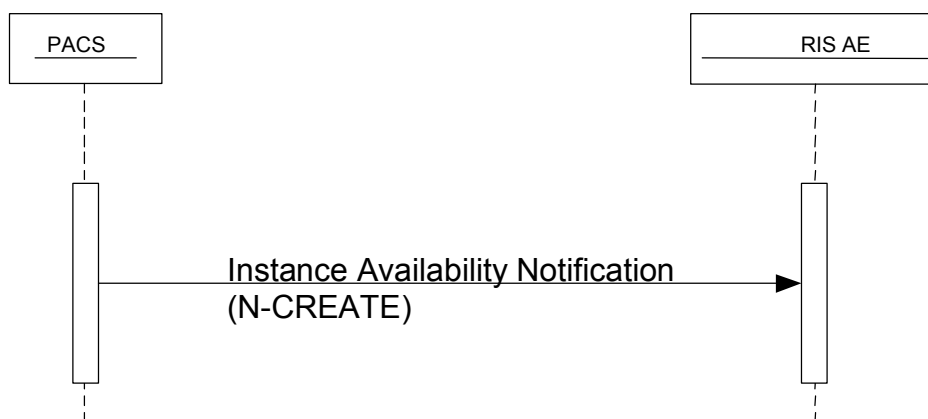

Figure 2.2-4: Instance Availability Notification Sequencing Diagram

2.2.1.4.3.1 Accepted Presentation Contexts

Table 2.2-16: Presentation Contexts Proposed

Presentation Context Table					
Abstract Syntax		Transfer Syntax		Role	Extended Negotiation
Name	UID	Name List	UID List		
Instance Availability Notification	1.2.840.10008.5.1.4.33	Implicit VR Little Endian	1.2.840.10008.1.2	SCP	None
		Explicit VR Little Endian	1.2.840.10008.1.2.1		

2.2.1.4.3.2 SOP Specific Conformance for IAN SOP Class

Only Study Instance UID (0020,000D) is used by IMPAX RIS to update a flag in the database to indicate that images are available.

2.3 Network Interfaces

IMPAX RIS Dicomserver provides DICOM V3.0 TCP/IP Network Communication Support as defined in PS 3.8 of the DICOM Standard. IMPAX-RIS inherits its TCP/IP stack from the computer system upon which it resides.

2.3.1 Physical Medium Support

IMPAX RIS Dicomserver is indifferent to the physical medium over which TCP/IP executes; it inherits the medium from the computer system upon which it is being executed.

2.3.2 Additional Protocols

2.4 Configuration

2.4.1 AE Title/ Presentation Mapping

2.4.1.1 Local AE Titles

Table 2.4-1: AE Title Configuration Table

Application Entity	Default AE Title	Default TCP/IP Port
IMPAX RIS Dicomserver	RIS_QUADRAT	2250

2.4.1.2 Remote AE Titles

Remote AE titles are stored in a configuration file and are entered via the GUI.

2.4.1.2.1 Remote SCP

Remote AET port number, host-names and IP addresses are stored in a configuration file, either the IP address or host-name is needed.

2.4.2 Configuration Parameters

Table 2.4-2: Configuration Parameter Table

Parameter	Configurable (Yes/No)	Default Value
General Parameters		
Time-out waiting for acceptance or rejection Response to an Association Open Request. (Application Level timeout)	No	100 seconds
General DIMSE level time-out values	No	100 seconds
Time-out waiting for response to TCP/IP connect request. (Low-level timeout)	No	100 seconds
Time-out waiting for acceptance of a TCP/IP message over the network. (Low-level timeout)	No	100 seconds
Time-out for waiting for data between TCP/IP packets. (Low-level timeout)	No	100 seconds
Any changes to default TCP/IP settings, such as configurable stack parameters.	No	100 seconds
Other configurable parameters	Logging on/off	off
AE Specific Parameters		
Size constraint in maximum object size (see note 1)	No	
Maximum PDU size the AE can receive	No	65542
Maximum PDU size the AE can send	No	65542
AE specific DIMSE level time-out values	No	
Number of simultaneous Associations by Service and/or SOP Class	No	
<SOP Class support> (e.g. Multi-frame vs. single frame vs. SC support), when configurable	No	
<Transfer Syntax support>, e.g. JPEG, Explicit VR, when configurable	No	Implicit VR Little Endian
Other parameters that are configurable		

3 MEDIA INTERCHANGE

Not supported.

4 SUPPORT FOR EXTENDED CHARACTER SETS

IMPAX RIS Dicomserver supports the following character sets:

• ISO-IR 6 (default)	Basic G0 Set
• ISO-IR 100	Latin Alphabet No. 1

5 SECURITY

5.1 Security Profiles

5.2 Association Level Security

IMPAX RIS Dicomserver keeps a list of allowed AE-titles. When the list is empty, all AE-titles are accepted.

5.3 Application Level Security

The RIS database is password protected.

6 ANNEXES

6.1 IOD Contents

6.1.1 Usage of Attributes from Basic Worklist Management IOD

IMPAX RIS Dicomserver provides standard conformance to the DICOM Basic Worklist Management Service Class.

6.1.2 Usage of Attributes from Modality Performed Procedure Step IOD

IMPAX RIS Dicomserver provides standard conformance to the DICOM Modality Performed Procedure Step Service Class.

6.1.3 Usage of Attributes from Instance Availability Notification IOD

IMPAX RIS Dicomserver provides standard conformance to the DICOM Instance Availability Notification Service Class.

IMPAX RIS Dicomserver uses the following elements for this SOP class (other elements are ignored):

Attribute Name	Tag
Study Instance UID	(0020,000D)



Details as of PDF Creation Date

Document Metadata

Title:	001212_IMPAX RIS v5.4.3 ; v5.5.x ; v5.6.x ; v5.7.x DICOM Conformance Statement
Livelihood ID:	19530802
Version#:	10
Version Date:	2009/12/02 03:54 PM CET
Status:	Approved on 2009/12/10 12:57 PM CET
Owner:	Peter Buytaert (awabr)
Created By:	Bruno Laffin (nawyv)
Created Date:	2007/10/04 01:50 PM CET
PDF Creation Date:	2009/12/10 12:58 PM CET

This document was approved by:

Signatures:

1. Sofie Neyrinck (amirm) on 2009/12/10 12:04 PM CET
2. Ann De Roose (amiqe) on 2009/12/03 05:16 PM CET
3. Bruno Laffin (nawyv) on 2009/12/03 04:09 PM CET

Detailed Approver History:

- Approval task originally assigned to and completed by Sofie Neyrinck (amirm)
- Approval task originally assigned to and completed by Bruno Laffin (nawyv)
- Approval task originally assigned to and completed by Ann De Roose (amiqe)

Version & Status History

Version#	Date Created	Status
10	2009/12/02 03:54 PM CET	Approved - 2009/12/10
9	2009/11/30 10:15 AM CET	Reviewed - 2009/12/01
8	2009/09/02 02:56 PM CET	Approved - 2009/09/21 Reviewed - 2009/09/10
7	2008/02/13 02:35 PM CET	Approved - 2008/02/14
6	2008/02/12 03:48 PM CET	Rejected - 2008/02/13

5	2008/02/11 05:01 PM CET	
4	2008/01/31 12:42 PM CET	Reviewed - 2008/02/11
3	2008/01/24 05:21 PM CET	
2	2007/10/04 02:05 PM CET	
1	2007/10/04 01:50 PM CET	